

LONDON
SCHOOL of
HYGIENE
& TROPICAL
MEDICINE



LSHTM Research Online

Jeong, K; (2017) Cost-effective strategies in the follow-up of people with confirmed colorectal adenomas for the prevention and early detection of colorectal cancer in the National Health Insurance, South Korea. PhD thesis, London School of Hygiene & Tropical Medicine. DOI: <https://doi.org/10.17037/PUBS.03894604>

Downloaded from: <https://researchonline.lshtm.ac.uk/id/eprint/3894604/>

DOI: <https://doi.org/10.17037/PUBS.03894604>

Usage Guidelines:

Please refer to usage guidelines at <https://researchonline.lshtm.ac.uk/policies.html> or alternatively contact researchonline@lshtm.ac.uk.

Copyright \copyright\ and Moral Rights for the papers on this site are retained by the individual authors and/or other copyright owners

<https://researchonline.lshtm.ac.uk>

LONDON
SCHOOL of
HYGIENE
& TROPICAL
MEDICINE



LSHTM Research Online

Jeong, K; (2017) Cost-effective strategies in the follow-up of people with confirmed colorectal adenomas for the prevention and early detection of colorectal cancer in the National Health Insurance, South Korea. PhD thesis, London School of Hygiene & Tropical Medicine. DOI: <https://doi.org/10.17037/PUBS.03894604>

Downloaded from: <https://researchonline.lshtm.ac.uk/id/eprint/3894604/>

DOI: <https://doi.org/10.17037/PUBS.03894604>

Usage Guidelines:

Please refer to usage guidelines at <https://researchonline.lshtm.ac.uk/policies.html> or alternatively contact researchonline@lshtm.ac.uk.

Available under license. To note, 3rd party material is not necessarily covered under this license: <http://creativecommons.org/licenses/by-nc-nd/3.0/>

<https://researchonline.lshtm.ac.uk>



**Cost-effective strategies in the follow-up of people with
confirmed colorectal adenomas for the prevention and early
detection of colorectal cancer in the National Health Insurance,
South Korea**

Kim Eyoung Jeong

**A thesis submitted in accordance with the requirements for the
Degree of Doctor of Philosophy of the
University of London
2017**

Supervisor: Professor John Cairns

**Department of Health Services Research & Policy
Faculty of Public Health & Policy
LONDON SCHOOL OF HYGIENE & TROPICAL MEDICINE**

DECLARATION BY CANDIDATE

I, Kim Eyoung Jeong, confirm that the work presented in this thesis is my own.
Where information has been derived from other sources, I confirm that this has
been indicated in the thesis.

SIGNED:

DATE:

ABSTRACT

Colorectal cancer (CRC) is the third most common cancer amongst South Koreans. Indirect evidence suggested CRC can be prevented, if not cured through the early detection and the subsequent removal of the precursor of CRC using colonoscopy (COL), the colorectal adenoma (polypectomy). The main aim of this thesis is to identify cost-effective strategies in the follow-up of people with confirmed colorectal adenomas (COL surveillance) for the prevention and early detection of colorectal cancer in the colorectal cancer screening (CRCS), National Health Insurance in Korea. To fulfil the main aim of this study, the following specific objectives were carried out: Estimation of adenoma recurrence post-polypectomy, identification of resources used in the CRCS and CRC treatment and the mapping of common pathways in the CRCS – this was achieved through a collaboration with a researcher in Korea by constructing a CRC cohort utilising the NHI data (2009-2012); Examination of the relevant cost-effectiveness evidence of COL surveillance in individuals with adenomas – this was achieved by conducting a review of the cost-effectiveness evidence in the prevention and early detection of CRC; A literature review of the Health State Utility Values (HSUVs) was conducted to identify methodologically robust HSUVs with health states of interest, this information was used for economic evaluation of COL surveillance; Identification of cost-effective strategies for COL surveillance utilising the findings from previous objectives. Results from a *de novo* cost-utility analysis indicated that a 0LR3HR (a COL 3 years post-polypectomy for high-risk) strategy is expected to be the most cost-effective in the follow-up of people with confirmed adenomas in the CRCS, NHI. The findings of this study will inform the COL surveillance policy in the CRCS, NHI. Approaches taken in this study and the findings can provide a foundation for

further comparative policy analyses in other Asian countries where similar rates of CRC are observed.

ACKNOWLEDGEMENTS

I am immensely grateful to my supervisor, Professor John Cairns, a role model. His supervision and wise advice helped me to grow as a researcher.

I am also grateful to Dr Heeyoung Lee, research collaborator for the CRC cohort analysis. My sincere thanks are extended to SG, EG and all my friends who have been understanding and helpful throughout this journey. Special thanks to fellow researchers in Tavistock Place, especially 'Club JC' who have become lifetime friends.

I would like to thank my parents and family in Korea and Italy for their support and encouragement over the years. From the bottom of my heart, I thank GL who has been the emotional tower of strength throughout the journey. *Grazie mille!*

I wish to dedicate this thesis to Joyce Jameson whom I know would be very proud of me if she were still around.

TABLE OF CONTENTS

DECLARATION BY CANDIDATE	2
ABSTRACT	3
ACKNOWLEDGEMENTS	5
TABLE OF CONTENTS	6
LIST OF TABLES	9
LIST OF FIGURES	11
LIST OF APPENDICES	12
LIST OF ABBREVIATIONS	14
1 INTRODUCTION, AIMS AND OBJECTIVES	17
1.1 Financing and operational structure.....	17
1.2 Health care service delivery.....	25
1.3 Health service provider payment.....	27
1.4 Colorectal adenomas and CRC in Korea	28
1.5 NCSPs and CRCS	33
1.6 Challenges and opportunities in CRCS and COL surveillance	38
1.7 Conclusion.....	46
1.8 Aims and objectives	47
2 SHORT-TERM ANALYSIS OF COLORECTAL CANCER SCREENING IN NHI, KOREA, 2009-2012	48
2.1 Preamble to Research Paper I	48
2.2 Research Paper I Short-term analysis of colorectal cancer screening in South Korea, 2009-2012.....	52
2.2.1 Abstract.....	52
2.2.2 Introduction	54
2.2.3 Methods.....	55
2.2.4 Results	59
2.2.5 Discussion	73
2.2.6 Conclusion.....	79
3 REVIEW OF ECONOMIC EVIDENCE IN THE PREVENTION AND EARLY DETECTION OF COLORECTAL CANCER	81
3.1 Preamble to Research Paper II	81
3.2 Research Paper II Review of economic evidence in the prevention and early detection of colorectal cancer	88
3.2.1 Abstract.....	88

3.2.2	Introduction	90
3.2.3	Methods.....	91
3.2.4	Results	92
3.2.5	Discussion	103
3.2.6	Conclusion.....	106
3.3	Updates of Research Paper II	107
4	SYSTEMATIC REVIEW OF HEALTH STATE UTILITY VALUES FOR ECONOMIC EVALUATION OF COLORECTAL CANCER.....	110
4.1	Preamble to Research Paper III	110
4.2	Research Paper III Systematic review of HSUVs for economic evaluation of CRC.....	115
4.2.1	Abstract.....	115
4.2.2	Introduction	116
4.2.3	Methods.....	117
4.2.4	Results	120
4.2.5	Discussion	129
4.2.6	Conclusion.....	132
5	COST-EFFECTIVE STRATEGIES FOR PEOPLE WITH CONFIRMED ADENOMAS IN THE PREVENTION AND EARLY DETECTION OF COLORECTAL CANCER IN COLORECTAL CANCER SCREENING, NATIONAL HEALTH INSURANCE IN KOREA	133
5.1	Preamble to Research Paper IV	133
5.2	Research paper IV Cost-effective strategies for people with confirmed adenomas in the prevention and early detection of colorectal cancer in colorectal cancer screening, National Health Insurance, Korea.....	137
5.2.1	Abstract.....	137
5.2.2	Introduction	139
5.2.3	Methods.....	144
5.2.4	Results	164
5.2.5	Discussions and conclusion	170
6	DISCUSSIONS AND CONCLUSION.....	176
6.1	Introduction	176
6.2	Findings of the thesis.....	177
6.2.1	Identification of common pathways in the CRCS and relevant costs by utilising the short-term analysis of CRC cohort, 2009-2012	177

6.2.2	Review of cost-effectiveness of COL surveillance and CRCS.....	178
6.2.3	Systematic review of HSUVs for economic evaluation of CRC	179
6.2.4	Identification of cost-effective strategies for COL surveillance in the CRCS, NHI	179
6.3	Overall limitations	180
6.3.1	Short-term analysis of CRCS using the NHI reimbursement data .	180
6.3.2	Potential selection biases in the reviews.....	181
6.3.3	Cost-effectiveness analysis of COL surveillance, CRCS.....	181
6.4	Overall contribution of thesis	182
6.5	Implications for policy.....	183
6.6	Areas for further research.....	188
6.7	Conclusion.....	189
	REFERENCES	190
	APPENDICES	208
	APPENDICES TO CHAPTER 2.....	208
	APPENDICES TO CHAPTER 3.....	215
	APPENDICES TO CHAPTER 4.....	247
	APPENDICES TO CHAPTER 5.....	268

LIST OF TABLES

CHAPTER 1

Table 1.1 LTCI population coverage	21
Table 1.2 NHI user charges and protection mechanisms for cancer patients	22
Table 1.3 Financing of CRCS	23
Table 1.4 Distribution of CRC stage at diagnosis in 2011	32
Table 1.5 Establishment and expansion of NCSPs	33
Table 1.6 Current NCSPs	34
Table 1.7 Discrepancies in the risk stratification of adenomas and identified gaps in the recommendations and current practice	44

CHAPTER 2

Table 2.1 Characteristics of CRC cohort	59
Table 2.2 CRCS compliance CRC cohort, 2009 and 2011-2012	60
Table 2.3 Mapping common pathways in the CRCS	61
Table 2.4.1 Average costs of CRC diagnosis per pathway	64
Table 2.4.2 Breakdown - Average costs of CRC diagnosis per pathway	65
Table 2.5.1 Summary costs of chemotherapy and radiotherapy for CRC in the NHI	67
Table 2.5.2 Average treatment costs of CRC per pathway, 2009-2012	67
Table 2.5.3 Breakdown - Average treatment costs of CRC per pathway	68
Table 2.6 Subgroup COL surveillance post-polypectomy, 2009-2012	69
Table 2.7 Reported COL findings from CRCS and risk stratification for economic model	70
Table 2.8 Adenoma recurrence at follow-up COL by presence of adenomas at the index COL in 2009	71
Table 2.9 AIC and BIC test results for assessing the suitability of survival models, COL surveillance subgroup	72
Table 2.10 CRC staging information submitted/used in CRCS	75
Table 2.11 Comparison of CRC stage using different classification system	76

CHAPTER 3

Table 3.1 CTC as a follow-up test	98
Table 3.2 Search update	108

CHAPTER 4

Table 4.1 CRC screening-related HSUVs	123
Table 4.2 Colostomy-related HSUVs	124
Table 4.3 Rectal cancer-related HSUVs	125
Table 4.4 HSUVs associated with CRC treatments and AEs	127
Table 4.5 HSUVs in CRC	128

CHAPTER 5

Table 5.1 Reported COL findings from CRCS and risk stratification in the model	142
Table 5.2 Discrepancies in the risk stratification of adenomas and identified gaps in the recommendations, current practice and the CRC cohort	143
Table 5.3 Key features of the economic analysis	146
Table 5.4 Summary of parameter inputs – transition probabilities	156
Table 5.5 Summary of parameter inputs – HRQoL (3-monthly)	158
Table 5.6 Estimated mean cost of diagnosis, treatment and follow-up of CRC	163
Table 5.7.1 Deterministic base-case analysis results	165
Table 5.7.2 Breakdown of costs and QALYs	166
Table 5.8 Full results of sensitivity analyses	167
Table 5.9 Probabilistic base-case results	168

LIST OF FIGURES

CHAPTER 1

Figure 1.1. NHI at a glance	20
Figure 1.2. Financial indicators of NHIS 2002-2012	24
Figure 1.3 Trends in selected cancer incidence rates, 1999-2012 in Korea	30
Figure 1.4 Trends in the 5-year relative survival rates (%) by the year of cancer diagnosis in Korea, 1993-2012	31
Figure 1.5 Process and management of CRCS	36
Figure 1.6 Outline of current CRCS in NHI, Korea	40
Figure 1.7 Gaps in the current CRCS NHI	41

CHAPTER 2

Figure 2.1 CRC cohort, 2009-2012	57
Figure 2.2 Identified common pathways in CRCS in 2009	62
Figure 2.3. Mapped common pathways in the CRCS in the CRC cohort, 2009-2012	63
Figure 2.4 Survival estimate post-polypectomy, CRC cohort 2009-2012	71
Figure 2.5. Extrapolated CRC-free survival curve post-polypectomy	73

CHAPTER 3

Figure 3.1 Included studies	92
Figure 3.2 At a glance – 195 comparisons	96
Figure 3.3 Updated Figure 2 At a Glance – 227 comparisons	109

CHAPTER 4

Figure 4.1 Numerical summary of the searches for the review	119
---	-----

CHAPTER 5

Figure 5.1 Gaps in the current CRCS NHI	139
Figure 5.2 Outline of the economic model	152
Figure 5.3 CE Plane: No COL surveillance and the strategies	169
Figure 5.4 CEAC	170

LIST OF APPENDICES

CHAPTER 2

Figure A2.1 Institutional Review Board (IRB), Seoul Bundang Hospital	208
Figure A2.2 Reporting form CRCS (2009)	209
Figure A2.3 CRCS mapping pathways I	210
Table A2.1 CRCS mapping pathways II	211
Table A2.2 Summary of recommended chemotherapy agents for CRC	214

CHAPTER 3

Table A3.1 Search strategy - MEDLINE	215
Table A3.2 Further details – Study selection criteria	216
Table A3.3 Included/excluded studies	217
Table A3.3.1 Included studies	218
Table A3.3.2 Excluded studies after full-text review	221
Table A3.4 Summary of included studies	224
Table A3.5 Search update - Included studies	246

CHAPTER 4

Table A4.1 Search strategy for MEDLINE	247
Table A4.2 Search strategy for mapping studies - MEDLINE	249
Table A4.3 Study selection criteria	250
Table A4.4 Included studies	251
Table A4.5 Summary of studies reporting HSUVs in CRC	255
Table A4.6 Summary of mapping studies	267

CHAPTER 5

Figure A5.1 Reporting form CRCS, NHI (2009)	268
Figure A5.2 Validation – probability of being alive over time in No COL surveillance and general population in Korea	269
Table A5.1 Steps taken for further search of economic evidence in Korea	270
Table A5.1.1 Key words, search strategy and selection criteria	270
Table A5.1.2 Quality assessment of cost-effectiveness studies in Korea	272
Table A5.2 Quality assessment: Whyte (2012)	273
Table A5.3 Comparison of CRC stage using different classification system	274
Table A5.4 Fixed transition probabilities	275
Table A5.4.1 Adenoma recurrence	275
Table A5.4.2 Fixed annual transition probabilities	275
Table A5.4.3 Fixed 3-monthly transition probabilities	276
Table A5.5 Steps taken to make the economic model probabilistic	277
Table A5.5.1 Posterior distribution parameters (yearly)	277
Table A5.5.2 Posterior distribution probabilities (yearly)	275
Table A5.5.3 Random Dirichlet probabilities (annual)	278
Table A5.5.5 Transition probabilities of adenoma-carcinoma (3-monthly)	278

Table A5.6 Steps taken to identify HSUVs of CRC in a Korean context	279
Table A5.6.1 Further search for HSUVs in a Korean context	279
Table A5.6.2 Studies identified for full-text review	280
Table A5.6.3 Ordinary least square regression model	281
Table A5.6.4 Summary statistics and mapped HSUVs	281
Table A5.7 Resources associated with COL and CRC in the NHI	282
Table A5.7.1 Summary of unit costs of COL surveillance and CRC diagnosis	282
Table A5.7.2 Summary of recommended chemotherapy agents for CRC	283
Table A5.8 Annual average OOP payments between people with and without cancer in Korea	284
Table A5.9 Description of SEER and the partial adoption of SEER in CRCS	285
Table A5.10 Summary of recommended chemotherapy agents for CRC	286
Table A5.11 Summary costs of chemotherapy, CRC treatment	287
Table A5.12 Costs of radiation therapy for CRC	287
Table A5.13 Validation of model - probability of being alive from age 50-100	288
Tables A5.14 Full results for sensitivity analyses	290
Table A5.15 Quality assessment: cost-utility analysis of COL surveillance in CRCS, NHI Korea	296

LIST OF ABBREVIATIONS

AE	Adverse event
BE	Barium enema
CE	Cost-effective
CEA	Carcinoembryonic antigen
CI	Confidence interval
CS	Colonoscopic surveillance
BSC	Best supportive care
BSG	British Society of Gastroenterologists
CapEndo	Capsule endoscopy
CEAC	Cost-effectiveness acceptability curve
CISNET	Cancer Intervention and Surveillance modelling Network
COL	Colonoscopy, colonoscopic
CRC(S)	Colorectal cancer (screening)
CTC	Computerised tomography colonography
DA	Dukes' A CRC
DB	Dukes' B CRC
DC	Dukes' C CRC
DD	Stage D CRC
DCBE	Double-contrast barium enema
DRG	Diagnosis-related group
EGFR	Epidermal growth factor receptor
EORTC QLQ	European Organisation for Research and Treatment of Cancer Quality of Life Group
FACT-C	Functional Assessment of Cancer Therapy-Cancer
FACT-G	Functional Assessment of Cancer Therapy-General
FFS	Fee-for-service
FIT	Faecal immunochemical test
FSIG	Flexible sigmoidoscopy
FOBT	Faecal occult blood test
FOLFIRI	Irinotecan + infusional 5 fluorouracil (5-FU)
FOLFOX	Oxaliplatin + infusional 5 fluorouracil (5-FU)
FU	Follow-up
GBP	Great British poun (£)
GDP	Gross domestic product
gFOBT	Guaiac faecal occult blood test
HCSU	Health care service utilisation
HEED	Health Economic Evaluations Database
HGD	High-grade dysplasia
HIRA	Health Insurance Review & Assessment
HR	High risk
HRQoL	Health-related quality of life
HSUV(s)	Health state utility value(s)
ICER	Incremental cost-effectiveness ratio
iFOBT	Immunochemical faecal occult blood test

KAMS	Korean Academy of Medical Society
KCCR	Korea Central Cancer Registry
KRAS	Kirsten rat sarcoma viral oncogene
KRW	Korean Won
LR	Low-risk
LTCI	Long-Term Care Insurance
LY(G)	Life Years (Gained)
MAP	Medical Aid Programme
mCRC	metastatic colorectal cancer
MISCAN	Micro Simulation Screening Analysis
MoHW	Ministry of Health & Welfare
MRI	Magnetic resonance imaging
NBI	Narrow-band imaging
NC	Non-compliant (to CRCS)
NCC	National Cancer Centre
NCSP	National Cancer Screening Programme
NECA	National Evidence-based Healthcare Collaborating Agency
NHIC	National Health Insurance Cooperation
NHI(S)	National Health Insurance (Service)
NICE	National Institute for Health and Care Excellence
OECD	Organisation for Economic Co-operation and Development
OOP	Out-of-pocket payment
PBM	Preference-based measure
PET	Positron-emission tomography
PRT	Preoperative radiotherapy
PS	Permanent stoma
PSA	Probabilistic sensitivity analysis
QALY	Quality-adjusted life years
QLQ	Quality of life questionnaire
Q-TWiST	Quality-adjusted time without symptoms of disease or toxicity of treatment
RC	Rectal cancer
RCT	Randomised controlled trial
REL	Relapse period until death or end of follow-up
RR	Relative risk
SEER	Surveillance, Epidemiology and End Results Programme
Se/Sp	Sensitivity/Specificity
SimCRC	Simulation colorectal cancer
TME	Total mesorectal excision
TNM	Tumor-Node-Metastasis
TOX	Days with \geq grade 3 adverse events
TTO	Time trade-off
TwIST	Time without symptoms or disease or toxicity of treatment
SIG	Sigmoidoscopy
SG	Standard gamble

UK	United Kingdom
US	United States
WHO	World Health Organisation
XELOX	Capecitabine plus oxaliplatin

1 INTRODUCTION, AIMS AND OBJECTIVES

South Korea (hereafter, Korea) is mostly urban with more than 50% of 50,977,027 Koreans concentrated in and around Seoul, the capital city [1]. The population is ethnically homogeneous with approximately 98% Koreans and life expectancy at birth was 81.3 years in 2010-2013 [2]. In 2015, 13.1% of the Korean population was 65 years and older and this proportion is projected to be 40.1% by 2060. 4 in 10 Koreans are going to be 65 years and older by 2030 [2]. The population projection implies a rapidly increasing demand for health services, and increasing incidence and prevalence of age-related chronic conditions including CRC.

In order to have a better understanding of the research questions posed, this chapter provides background information concerning an overview of the health care system in Korea with regard to financing and operational structure health care service delivery, and health service provider payment and overviews of national cancer screening programmes (NCSPs) and CRCS are introduced. Also presented are the identified challenges and opportunities in the current CRCS followed by the aims and objectives of this thesis.

1.1 Financing and operational structure

The Ministry of Health and Welfare (MoHW) has overall responsibility for the National Health Insurance (NHI), it produces strategies and policies concerning the health system including financing, insurance, benefits systems, health care, traditional medicine, long-term care and oversees the operation of the NHI. National Health Insurance Service (NHIS), formerly known as National Health

Insurance Cooperation (NHIC), as a single insurer manages the NHI membership, collects NHI contributions, provides health insurance benefits, health check-ups and CRCS as part of the NCSP and provides access to a range of services and cost containment [3]. Health Insurance Review & Assessment (HIRA) is responsible for the reviews and assessments of health service fees [4-6]. The overview of NHIS associated with MoHW and HIRA is presented in Figure 1.1.

MoHW and NHIS specify the list of benefit packages covered by NHI and determine the fee schedule for insured health services each year [5, 7]. Health care institutions (mainly hospitals and clinics) submit reimbursement requests to HIRA, and HIRA undertakes the evaluation of the health care service fee, sends the review results to NHIS and the requesters. HIRA also conducts the evaluation of the quality of health care institutions and adequacy of health care services [8].

A new health technology assessment (HTA) committee was set up in 2007 where the new and existing technologies were reviewed for a reimbursement decision at HIRA. The National Evidence-based healthcare Collaborating Agency (NECA) leads the HTA research on pharmaceutical products, medical devices and diagnostics; however, the review and recommendations have been made by HIRA which supports the decision making process of the MoHW. There is an increase in demand for the reviews of health technologies in the NHI from the stakeholders with the rapidly rising health care expenditure and ageing population in Korea coupled with finite resources in the NHI, economic evaluation was introduced to aid the decision making process for pharmaceutical products in the NHI led by HIRA [9].

However, HIRA's guidelines for economic evaluation do not indicate a specific cost-effectiveness threshold but the implicit willingness-to-pay (WTP) is said to

be Korean Won (KRW) 30,000,000 per quality-adjusted life years (QALY) gained (This personal communication was in confidence and the person wishes to remain anonymous). The lack of a cost-effectiveness threshold communicated to stakeholders often creates myths and mistrust about the reimbursement decisions made by MoHW among stakeholders in Korea [10].

There are three health security programmes – Medical Aid Programme (MAP), long-term care insurance (LTCI), and National Health Insurance (NHI) – in the Korean health care system [8]. MAP, introduced in 1979, is a government initiated medical benefit programme for low-income households unable to afford health care. About 2% of Koreans whose income falls below the minimum standard of living are covered by MAP [4, 6]. MAP coverage was recently expanded to those with rare, intractable and chronic diseases and to children up to 18 years of age [8, 11].

Figure 1.1 NHI at a glance (www.nhic.or.kr)

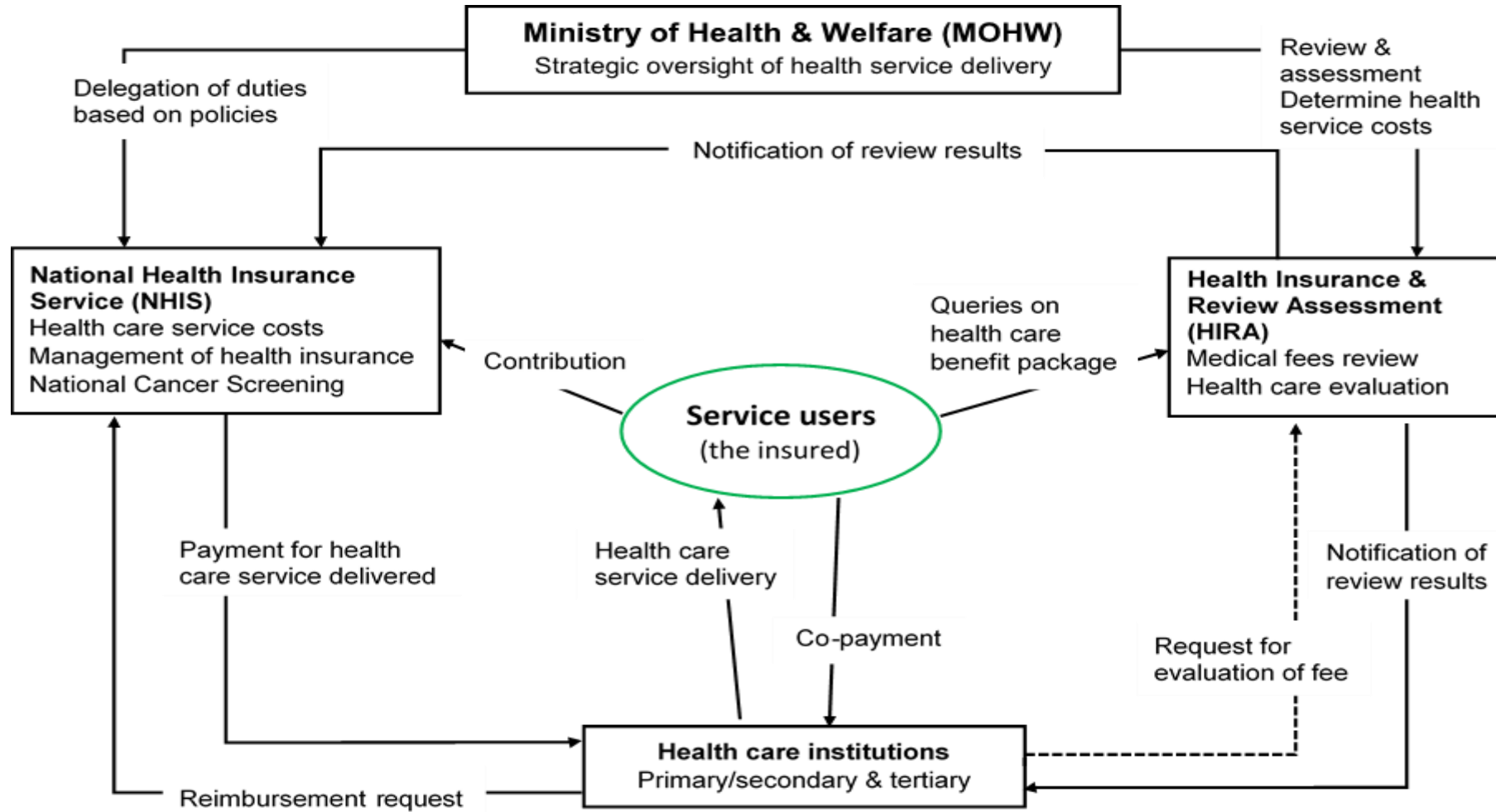

The LTCI was introduced in 2008 to provide support to individuals 65 years and older and their informal carers. Individuals aged 65 years and older with ‘age-related’ physical and cognitive conditions were eligible for LTCI through an assessment of physical and cognitive function. Table 1.1 presents the population coverage of LTCI. Since its introduction, the service usage of LTCI went up from 53% in 2008 to 99% in 2012 [6, 12].

Table 1.1 LTCI population coverage

	2008	2009	2010	2011	2012
Number of people eligible for LTCI (% of the elderly)	146,643 (2.9%)	268,000 (5.2%)	308,000 (5.7%)	318,000 (5.8%)	327,766 (5.7%)
Number of used services (% of those eligible for LTCI)	78,000 (53%)	184,000 (69%)	245,000 (79%)	280,000 (88%)	318,266 (99%)

LTCI Long-term care insurance

NHI, founded in 1977, is a public not-for-profit organisation and a single purchaser of health services in Korea [4, 6]. Strong political will coupled with rapid economic growth enabled an achievement of universal coverage following the initial patchy coverage of social health insurance in 1977, coverage was expanded to 98% of Korean by 1987 [5, 13]. As a compulsory social insurance, NHI is funded through beneficiaries’ contributions, government subsidies and substantial out-of-pocket (OOP) payments and is regulated by the MoHW and NHIS [5, 6]. The insured (health service users) pay a monthly premium contribution (NHI contribution) and a co-payment at the point of health service use as presented in Table 1.2 [4]. NHI contribution rates are determined by ability to pay: calculated using the beneficiaries’ wage (if employed, equally shared

between employers and employees) or self-reported income and property (if self-employed) [4, 14].

Table 1.2 NHI user charges and protection mechanisms for cancer patients

(Unit: KRW; KRW 1,000=GBP 0.56)

Health service	Inpatient	Outpatient
Co-payment rates for service users	In general, 20% of total treatment cost 5% for registered cancer patients 10% for registered rare/incurable disease	Ceiling on OOP payment for 6 months - for lower income* percentile 50%, KRW 2 million - for middle income* percentile 30%, KRW 3 million - for higher income* percentile 20%, KRW 4 million
Exemptions/ discounted rates	Tertiary (specialist general) hospital - 60% of total treatment cost and other expenses General hospital - 45-50% (depending on administrative districts in rural areas: Eup, Myeon or Dong) of total care benefit expenses Pharmacy for outpatient prescriptions - 35-40% (depending on administrative districts: Eup/Myeon or Dong) of total care benefit expenses Hospital - 30% of total care benefit expenses Physicians' clinic (primary care), public health centre - 30% of total care benefit expenses	Ceiling on OOP payment for 6 months - for lower income* percentile 50%, KRW 2 million - for middle income* percentile 30%, KRW 3 million - for higher income* percentile 20%, KRW 4 million
Protection mechanisms	Age 6 years and younger , fixed rate: 10% Reduced co-payment rate for severe diseases including cancer, chronic renal failure, severe burns, rare and incurable disease	Pharmacy for outpatient prescriptions - 65 and older, fixed amount (KRW 1,200) if total < KRW 10,000 Physicians' clinic (primary care), public health centre - 65 and older, fixed amount (KRW 1,200) if total < KRW 10,000 Reduced co-payment rate for severe diseases including cancer, chronic renal failure, severe burns, rare and incurable disease

*Calculation based on average monthly household income and assets; **GBP** Great British Pound; **KRW** Korean Won; **NHI** National Health Insurance; **OOP** out-of-pocket

CRCS and other NCSPs are funded through NHI and central and local government taxes, see Table 1.3 [15]. CRCS and other NCSPs are typically performed at outpatient clinics. For those whose income level falls within the top 50 percentile, 90% of the fee for CRCS is paid by NHI and 10% by the insured. CRCS is offered free for those with income in the lowest 50 percentile, including MAP recipients [16].

Table 1.3. Financing of CRCS

	NHI insured (%)	MAP beneficiaries (%)
Central government	5	50
Local governments	5	50
NHIS	90	-

CRCS colorectal cancer screening programme; **MAP** Medical Aid Programme; **NHI** National Health Insurance; **NHIS** National Health Insurance Service

The estimated total spending on the NCSP in 2011 was KRW 4.45 trillion [13, 17]. Total health spending as a share of gross domestic product (GDP) was 7.5% in 2012 below the Organisation for Economic Co-operation and Development (OECD) average of 9.3%, however health spending is increasing at a faster rate than GDP in Korea [18]. Since 2002, tobacco tax is used exclusively as additional funds for the NHI scheme to help keep the financial balance of the NHI [4]. NHIS revenues and expenditures from 2002 to 2012 are presented in Figure 1.2 [17].

Figure 1.2. Financial indicators of NHIS 2002-2012

(Unit: KRW; KRW 1,000=GBP 0.56)

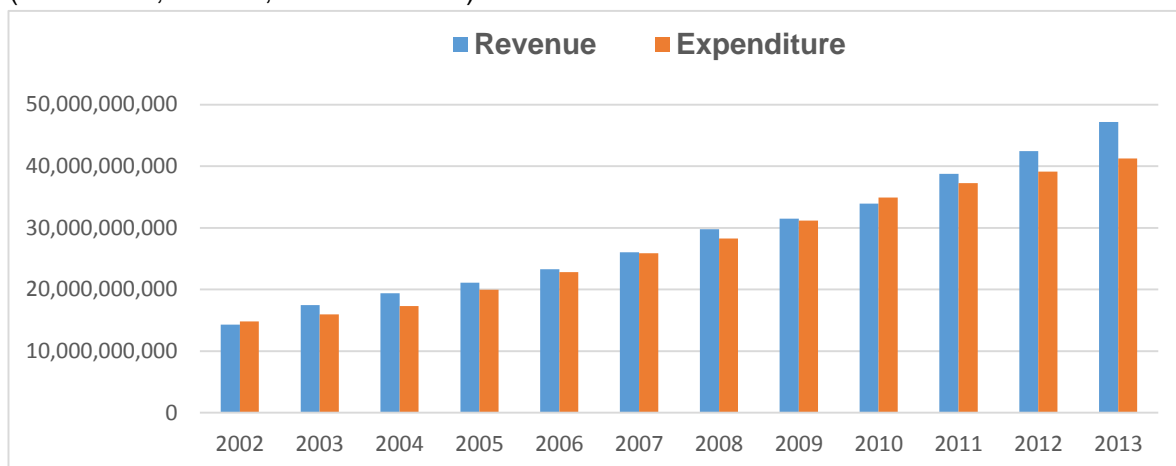

GBP Great British Pound; **KRW** Korean Won; **NHIS** National Health Insurance Service

All Koreans are covered by either NHI or MAP, however, public expenditure as a proportion of total health expenditure is 55.3%, lower than the OECD average of 72.5% indicating limited protection against catastrophic medical expense spending for the insured [18]. The government introduced financial benefits for cancer patients, including a recently introduced maximum cap on OOP payment by cancer patients in a given period to ease ongoing problems of limited benefit coverage and catastrophic expenses paid through OOP payments as presented in Table 1.2 [19, 20]. The reported total economic burden of CRC was KRW 3.1 trillion in 2010 which makes CRC the third largest economic burden among all cancers in Korea [15, 21]. Therefore, the importance of preventive measures through screening and structured management of follow-up is considerable [19, 20, 22].

1.2 Health care service delivery

Approximately 90% of health care is delivered by private practitioners or organisations, in other words, in Korea most health care institutions are for-profit owned by physicians [7]. Primary care institutions include clinics, dental hospitals and general hospitals [4]. Secondary care services provide primary care and complex specialised services at clinics/hospitals. Forty-four tertiary care institutions (specialised general hospitals), typically university hospitals with high-tech medical equipment, are located in the capital and metropolitan cities. For the purpose of cost control and financial sustainability of NHI patients, referrals to secondary care services made by primary care institutions are covered by NHI, otherwise, all expenses are borne by service users except for child birth and emergencies [4]. NHIS outlines the minimum coverage and minimum standards for health care services/facilities [8]. Guidelines for CRCS and other NCSPs are set out by the National Cancer Centre (NCC) which often conflict with various clinician-led guidelines for CRCS [8, 23, 24]. Individuals are dependent on the clinicians' advice on the modality and intensity of CRCS, this results in frequent screening tests leading to OOP payments [25]. Some clinicians prefer to be cautious thus recommend additional tests outside the CRCS to individuals while it is also seen as the compensatory behaviour for the lower reimbursement fee for a COL by NHI. Under the strict control of the health service fee by the government, unnecessary use/delivery of health care services was reported among for-profit hospitals and clinics [7, 19, 26]. The deregulation of health care institutions in 1990 resulted in an increasing number of beds in hospitals for acute care service, this triggered the increasing number of health care institutions over

the period of 2000-2013 leading to fierce competition and marketing among health services providers. [4, 8].

The characteristics of NHI include a short waiting time and a comprehensive NHI electronic data system [19, 27]. NHI service users have the right to choose their preferred health service providers, facilities, specialists and general practitioners within the health institutions for outpatient clinics visits, as well as the type of inpatient facilities (namely, 'high class' versus 'normal class' ward). Such privileged users' choices come with additional premium charges. Furthermore, NHI service users often choose the methods of treatments for themselves to a certain degree, profoundly based on their clinicians' advice which seem to have conflict of interests as clinicians have their own interests for their for-profit private practice [4, 6, 27]. Although primary care institutions (clinics, dental hospitals and general hospitals) are the recommended first point of contact in the NHI, secondary care institutions are preferred by service users. In theory, one should obtain a referral letter from a primary care physician in order to access secondary care, however, there is no such gate-keeping in the NHI. Service users tend to prefer a university hospital in a major city to a primary clinic despite the higher co-payment fee schedule. Some opt for opportunistic health screening outside the NCSPs in order to obtain a second opinion or 'double-check' their CRCS results with their preferred specialists/hospitals outside the CRCS [13]. The average number of visits to health care institutes per person per year was reported to be 11.8 compared with the OECD average of 6.8 in 2006 [4].

1.3 Health service provider payment

Since 1977, outpatient based health care services, including colonoscopy, is primarily reimbursed through fee-for-service (FFS) methods, which is the payment of actual costs incurred per unit of service delivered retrospectively. This fee has been regulated by the government which has been a source of ongoing friction between the government and health care institutes [7]. Approximately, 90% of health services are delivered by private health institutes with a strong profit orientation under the FFS payment system [4]. Consequently, current FFS payments for outpatient based health service give health service providers strong financial incentives to deliver more units of complex interventions/service at outpatient clinics [7]. For example, a typical outpatient visit for a minor condition would entail 2-3 separate visits for the repeat prescriptions every other day [28]. Most health care service providers tend to add non-insured items (that are not regulated by the government) into tailored health screening packages, or provide a comprehensive CRCS package that includes both insured and non-insured items [28]. A number of comprehensive health screening packages are fiercely marketed, starting from KRW 626,000 for a basic package to an undisclosed amount for a 'First Class' package which includes providing over-night stays with a limousine and valet parking services in a designated unit [29, 30]. A COL procedure is reimbursed at KRW 74,240 (average) in the CRCS [31]. On the other hand, the reimbursement of COL was reported to be 9 to 95 times higher in the US, 28 times higher in the UK and 7-14 times higher in Singapore than in the CRCS, Korea [32].

In 2002 the diagnosis-related groups (DRGs) were introduced for the in-hospital stays for selected conditions/diseases in an attempt to control 'overuse of medical services' that are reimbursed through a FFS [7]. State-regulated medical fees have long been recognised as insufficient to cover the basic costs of health service, and insufficient to ensure the effectiveness, efficiency and financial sustainability of NHI [5, 7, 11, 32]. With the rapidly increasing health care expenditure the government attempts to move towards evidence-informed decision-making for health care, the use of economic evaluation of existing CRCS and NCSPs would provide a better alternative to stage-regulated cost control for the NHI in the long term [19, 26].

1.4 Colorectal adenomas and CRC in Korea

Colorectal adenoma (henceforth, adenoma) is a type of polyp, abnormal tissue growth in the rectum or the colon which can be either pre-cancerous or benign [33]. Polyps can be categorised by the major histological groups of hyperplastic/metastatic polyp, neoplastic polyp and adenomatous polyp (adenoma). Adenomas are classified as tubular, villous or tubulovillous based on histological examinations [34, 35].

Although CRCS and COL are widespread, the natural history of adenoma-carcinoma remains understudied. COL surveillance studies indicate that individuals who did not have COL surveillance have a three- or fourfold risk of CRC compared to individuals who had COL surveillance [36]. Indirect and non-randomised controlled trial evidence indicate the potential benefits of polypectomy (that is the removal of polyps and adenomas) associated with a

reduction in CRC mortality and morbidity [33]. Transformation of adenomas into carcinomas is said to take on average 10-15 years [37]. The number and estimated size of adenomas are positively related to the potential future risk of developing CRC [38]. People who have adenomas removed, require lifetime follow-up in order to detect and prevent CRC [39].

Direct measurement of the adenoma-carcinoma sequence or the true incidence of adenomas is not possible due to ethical reasons and CRCS being widely offered to everyone in many countries. Therefore, consideration should be given to commissioning more research on the natural history of adenoma-carcinoma by utilising registry and reimbursement datasets in order to fill the gaps in the evidence-base, as not all questions can be answered through RCTs because of practical or ethical issues.

In Korea, the incidence rate of adenomas is increasing in proportion to the rapid increase in CRC incidence [40]. In a retrospective COL study comprised of 2,435 Korean adults, over the period of 1998-2004, the prevalence of polyps was 30.2%, of which 4.1% was advanced adenomas [41]. The prevalence of adenoma was 33.3% and advanced adenoma 2.2% in a prospective study of 2,307 asymptomatic average-risked Koreans in 2003-2004 (mean age \pm SD, 52.1 \pm 11.6) [21]. For people at average risk (that is without a history of adenomas or a family history of CRC) the prevalence of adenomas was comparable to western countries [21, 24, 42-45]. Age, male gender and a history of adenomas are known risk factors for CRC among Koreans [46, 47]. Individuals with previous adenomas are three times as likely to develop CRC as people with no previous colorectal adenomas [46]. Therefore, structured management of people with confirmed adenomas is priority in the current CRCS that aims to detect and prevent CRC.

Figure 1.3 Trends in selected cancer incidence rates, 1999-2012 in Korea [48]

(Unit: per 100,000)

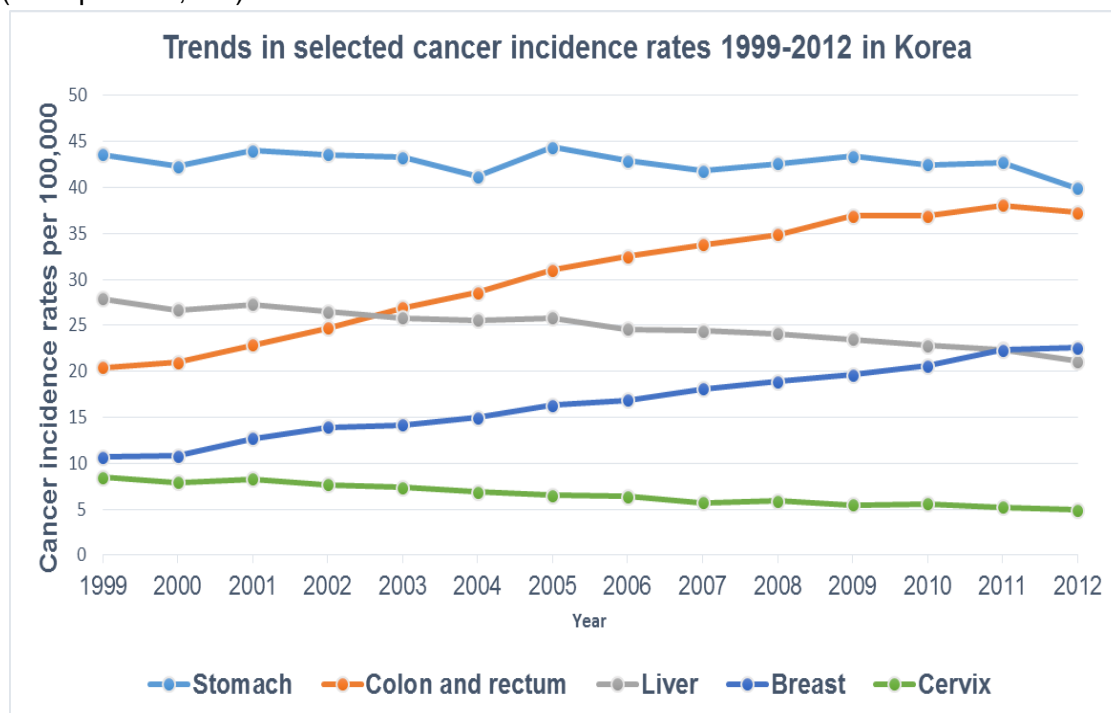

Cancer, in general, has been the primary cause of death over decades, with 1 in 3 people dying of cancer in Korea [15]. CRC is the third most commonly diagnosed cancer in Korea and the reported CRC incidence in 2012 and mortality rates continued to rise every year whilst stomach and liver cancer incidence rates steadily decreased over the period of 1999-2012 as presented in Figure 1.3 [48]. A total of 28,988 new CRC cases and 8,135 deaths due to CRC were reported during the year of 2012. Of all cancer deaths in 2012, the main sites of cancers in the lung, liver, stomach, and colon and rectum accounted for about 61.6% of the total [18].

Figure 1.4 Trends in the 5-year relative survival rates (%) by the year of cancer diagnosis in Korea, 1993-2012 [48, 49]

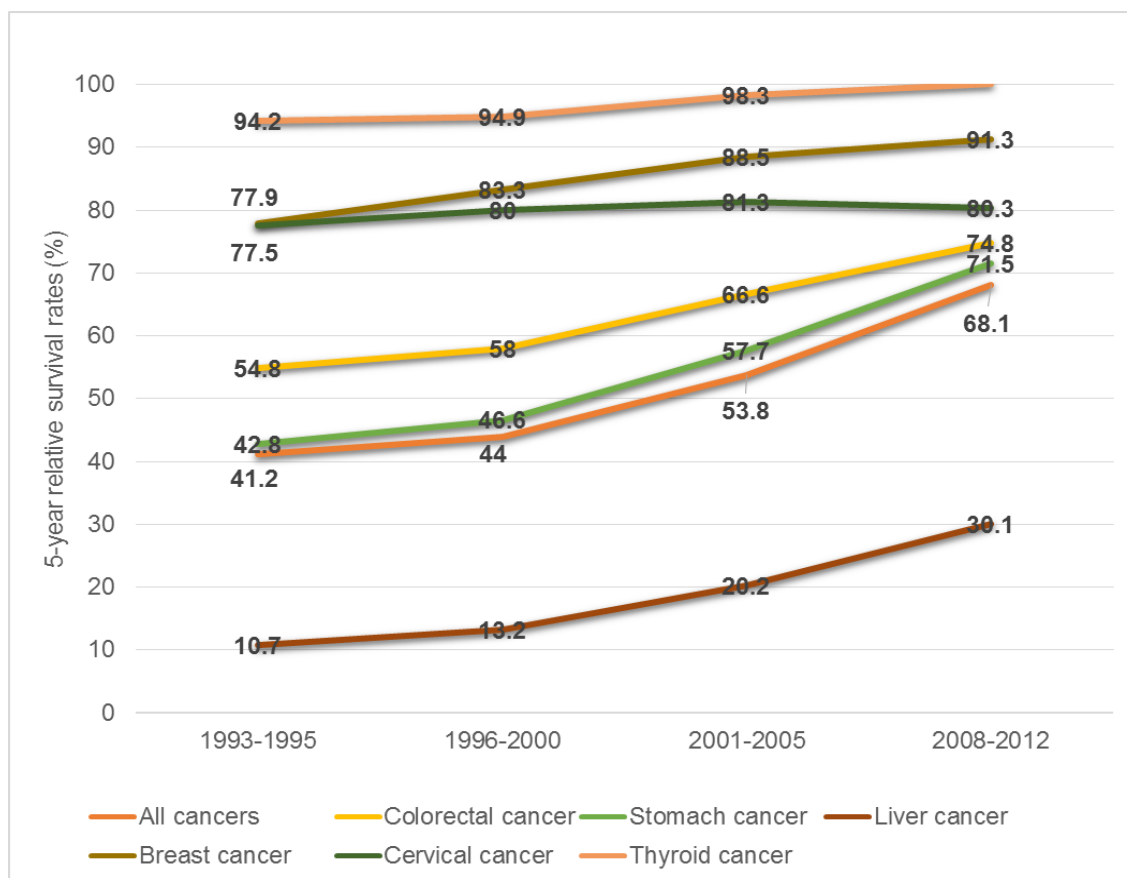

The relative 5-year survival rate of CRC improved by 20% from 1993-1995 to 2008-2012 in conjunction with the widened population coverage of CRCS and technological advances in treatments of CRC (see Figure 1.4) [48, 49].

The direct cost of CRC was reported to be KRW 1.97 trillion (KRW 1,000=Great British Pound (GBP) 0.56) and the reported indirect cost was KRW 1.16 trillion in 2010 [49]. Koreans perceive cancer as a serious threat, thus many people are willing to spend on opportunistic cancer screenings that is 100% not covered by the NHI. NHI spending on NCSP reached KRW 71,200,000,000 with the number

of providers of the screening programme rising to 8,514 in April 2011 [13]. Of the reported KRW 3.1 trillion total economic burden of CRC in 2010, KRW 1.97 trillion (63%) was spent on direct costs. Therefore, the true costs of CRC treatment would be much greater when OOPs are accounted for. The estimated economic burden of CRC was 3.122 trillion KRW in 2010 compared with 1.4 trillion KRW in 2005 [49].

Table 1.4 Distribution of CRC stage at diagnosis in 2011 [50]

CRC stage	Definition	Approximate proportion at CRC diagnosis (%)	Number of patients diagnosed by stage of CRC
Stage I	Cancer localised within the bowel wall	22.2	4,073
Stage II	Cancer penetrating the bowel wall	28.6	5,237
Stage III	Cancer in lymph nodes	35.8	6,571
Stage IV	Distant metastases (commonly in the liver)	11.8	2,169
Unknown	Disease stage not recorded	1.4	260

CRC colorectal cancer

Of the estimated proportions of patients with different stages of CRC, approximately 47% of CRC was detected at stages III and IV in 2011 as presented in Table 1.4 [50]. A total of 73, 759 deaths were caused by all cancers in Korea in 2012 accounting for 27.6% of all deaths, and, in this year, the age-standardised CRC mortality rate was 9.7 per 100,000 [48]. Localised CRC (stage I) was treatable with a 5-year relative survival of 91% when the disease was detected and treated in the period between 2007-2011 [15].

CRC progresses slowly from adenomas which gives a window of opportunity to have the precursor of CRC removed or CRC detected at an earlier stage to improve prognosis through COL surveillance post-polypectomy (henceforward COL surveillance) and CRCS [38, 51]. CRC causes significant economic burden and the opportunity cost of COL surveillance within the current CRCS needs to be estimated in order to achieve the aim of CRCS: the prevention and early detection of CRC in the NHI, Korea [46, 49, 52, 53].

1.5 NCSPs and CRCS

The great socioeconomic impact of cancer, including CRC, prompted the rapidly introduced policy initiative, the NCSP in 1998 [15].

Table 1.5 Establishment and expansion of NCSP

	NCSP coverage		Offered NCSPs	Comments
	MAP	NHI		
1999	Yes	No	Stomach, breast, cervical cancers	
2002	Yes	*Low 20%	Stomach, breast, cervical cancers	Coverage expanded
2003	Yes	*Low 30%	Stomach, breast, cervical, liver cancers	Liver cancer added to NCSPs, coverage expanded
2004	Yes	Limited to *low 30%	Stomach, breast, cervical, liver and colorectal cancers	CRCS added to NCSPs
2005	Yes	Limited to *low 50%	Stomach, breast, cervical, liver and colorectal cancers	Coverage expanded to the 50% income bracket

***Low 20-50%** NHI contribution rates are calculated based on reported household income and assets every year for the following year's contribution rates. For the household income that falls lower than 20-50% of all the NHI insured, NCSPs are offered for free in the following year; **CRCS** colorectal cancer screening programme; **MAP** Medical Aid Programme; **NCSP** National Cancer Screening Programme; **NHI** National Health Insurance

The aim of the NCSP is to promote the awareness of cancer prevention and offer free screening to those unable to afford opportunistic screening or who were not screened during regular occupation-based health checks [13].

In 2004 CRCS was added to the existing NCSPs (cervical, breast, stomach and liver) that initially offered a faecal occult blood test (FOBT) to MAP beneficiaries, then gradually expanded to the general population by 2007/2008 as summarised in Tables 1.5 and 1.6 [8].

Table 1.6 Current National Cancer Screening Programmes

	Target population	Modalities reimbursed by NHI	Interval	Started year	Percentage paid by (NHIS/ service users)
Breast Cancer	Age 40 and older female	Mammography and breast clinical examination	2 yearly	1999	(90/10)
Stomach cancer	Age 40 and older	Gastric contrast x-ray or gastric endoscopy	2 yearly	1999	(90/10)
Cervical cancer	Age 30 and above female	Cervical smear	2 yearly	1999	(90/10) then (100/0)
Liver cancer	Age 40 and above with confirmed liver cirrhosis or Hepatitis B or C positive	Liver ultrasound sonogram and plasma alpha-feto protein test	6 months	2008	(90/10)
Colorectal cancer	Age 50 and above	COL or DCBE if FOBT positive	yearly	2004	(90/10)

COL colonoscopy; **DCBE** double-contrast barium enema; **FOBT** faecal occult blood test; **NHI** National Health Insurance; **NHIS** National Health Insurance Service

Following the establishment and expansion of NCSPs as the main focus of the 1st 10-year Plan for National Cancer Control (NCC) (1996-2005), the 2nd 10-year Plan for NCC (2006-2015) aimed to reduce the incidence of cancer and cancer

mortality through systematic cancer management, follow-up strategies and management of cancer risks [54]. The MoHW announced targets for 5-year cancer survival increased from 54% to 67% by 2015 in the 2nd Cancer Control Plan. The main objectives of the 2nd Plan included raising the level of awareness in the prevention of cancer, increasing the level of compliance in cancer screening and encouraging innovation in cancer treatment. Guaranteed access to the NCSPs and improved compliance rates remain as priorities [54]. Areas for further evaluation including economic evaluation or the structured management of follow-up strategies of the NCSPs remain under-studied [11, 52, 55].

The main aim of CRCS is to detect and remove the precursor of CRC, adenoma(s), to interrupt the adenoma-carcinoma sequence. Figure 1.5 outlines the process (in black) and the flow of funding (in blue) of CRCS. The centrally allocated funding for CRCS to each city or region is deposited at the NHI, and NHI pays for the CRCS service to the health service providers [56]. Each year a database of individuals eligible for CRCS is generated from the central database at the NHI, this information is shared with NCC. These eligible individuals receive an invitation to annual FOBT from NHI. FOBT is offered to individuals 50 years and older and the results are notified to participants within 15 days. For those with positive FOBT results, further information on a recommended follow-up test is included in the notification.

Figure 1.5 Process and management of CRCS

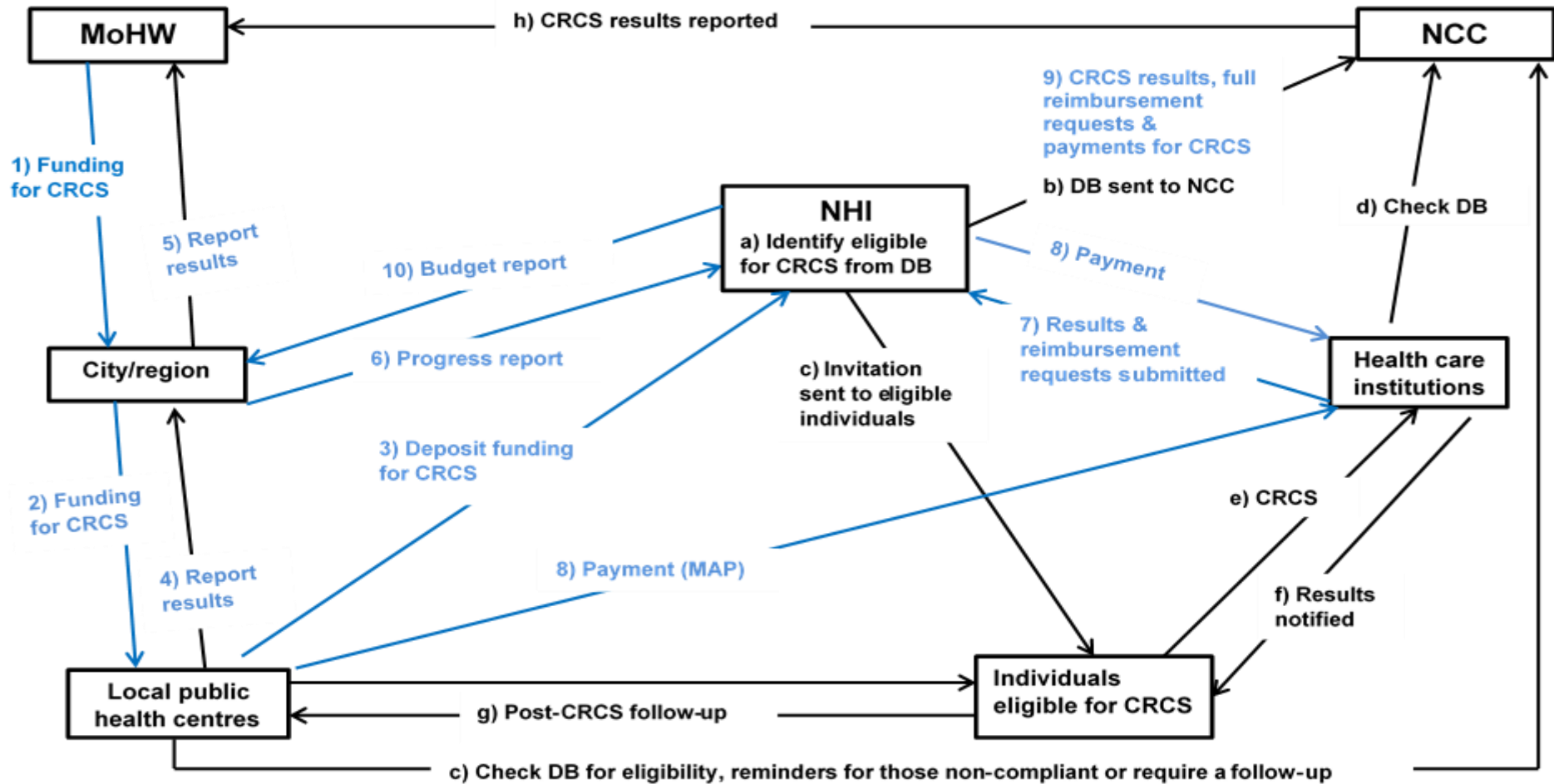

CRCS colorectal cancer screening; DB database; MAP Medical Aid Programme; MoHW Ministry of Health & Welfare; NCC National Cancer Centre; NHI National Health Insurance; blue arrows indicate the flow of funding; black arrows indicate the process

Stool tests are used to detect blood from adenoma/polyps or cancerous tumours. Guaiac FOBT (gFOBT) or immunochemical FOBT (iFOBT) are recommended as a primary CRCS owing to their relatively low cost and convenient administration which allow a wider population to be reached. iFOBT is widely used in the current CRCS [31, 40]. Individuals eligible for CRCS (age 50 and older) are sent a stool test kit with a return address by post, with instructions on how to collect and return the stool sample. Results are usually notified to individuals with advice of further testing by either COL or double-contrast barium enema (DCBE) for those with a positive FOBT result [15].

COL enables the examination of the lining of the whole large bowel using a long flexible tube with a light and a camera at the end of the tube. This method is commonly used as a 'gold standard' in CRCS because it provides a full view of the colon and rectum with the option of the removal of foreign benign or cancerous bodies during the procedure [57]. COL is an invasive procedure and has rare but potentially fatal complications such as perforation and bleeding from the removal of adenomas. COL requires a thorough bowel preparation 24-48 hours prior to the procedure and may require light sedation during the procedure [15].

Sigmoidoscopy (SIG), an invasive technique visualising the distal colon, alone or with the combination with DCBE is reimbursed by NHIS for people with positive FOBT results. In contrast, SIG is relatively under-utilised in the clinical practice because of the need for further COL in case of positive findings such as neoplasms or polyps [40].

DCBE is less invasive than COL, but DCBE is not as sensitive as COL in detecting adenomas that are smaller than 9 mm in diameter [40, 58-60]. As

evidence suggests DCBE is less effective than COL in detecting adenomas, DCBE is not recommended in CRCS [24, 40].

Computerised tomography colonography (CTC) is an advanced diagnostic imaging technology. CTC requires pre-test bowel preparations by the patient ingesting radiopaque contrast media and colonic distension which causes discomfort post-procedure [40]. CTC usually takes about 10 minutes in the scanner with no sedation therefore no additional resources for recovery are required post-procedure. In the event of positive findings from CTC, patients require a COL for further investigation. Some expressed concerns on the potential harms caused from additional exposure to low-dose radiation from CTC, but specialist radiologist-led studies reported that the minimum level of health effects from low-dose radiation exposure is outweighed by the greater potential benefits gained [61-63]. Clinical effectiveness of CTC in CRCS remains uncertain [63, 64]. CTC is currently outside CRCS thus is paid predominantly by OOP or 3rd party payment.

1.6 Challenges and opportunities in CRCS and COL surveillance

Early detection and prevention of CRC are feasible through CRCS and COL surveillance due to the slow transformation of adenomatous polyps into carcinoma, and the relatively long sojourn time before presenting symptoms [38, 39]. Existing guidance recommends post-screening management through planned follow-up COL in order to prevent interval cancers and CRC related mortality in several countries [39, 51, 59, 65, 66]. The economic burden of CRC

is considerable in line with the increasing CRC incidence among the aging Korean population [49]. The need for Korean evidence on the cost-effectiveness of COL surveillance based on Korean evidence has not been addressed [67].

Current CRCS policy ends with the results notified to individuals by post within 15 days of screening, and as a follow-up measure telephone advice and/or individual visits are offered to those with positive results depending on available resources [15]. Individuals with positive FOBT results are given full responsibility for deciding to seek further medical opinion and/or help. There is no formal network or data system where continuity of care could be provided related to clinical conditions identified through CRCS [13]. Clear guidance and structured management of positive FOBT results is lacking within the existing CRCS [68]. Significant resources have been committed to the CRCS over a decade, yet there are no recommendations on the structured management of people with identified risk of developing CRC or economic evaluation of structured COL surveillance [26]. An individual with CRC diagnosis or adenomas continues with an annual invitation of FOBT within the current CRCS in the NHI (see Figure 1.6). Identified gaps related to COL follow-up strategies (marked with a red-dotted line) and the focus of economic evaluation of this thesis (marked with the green-dotted circle) in the existing CRCS are presented in Figure 1.7.

Figure 1.6 Outline of current CRCS in NHI, Korea

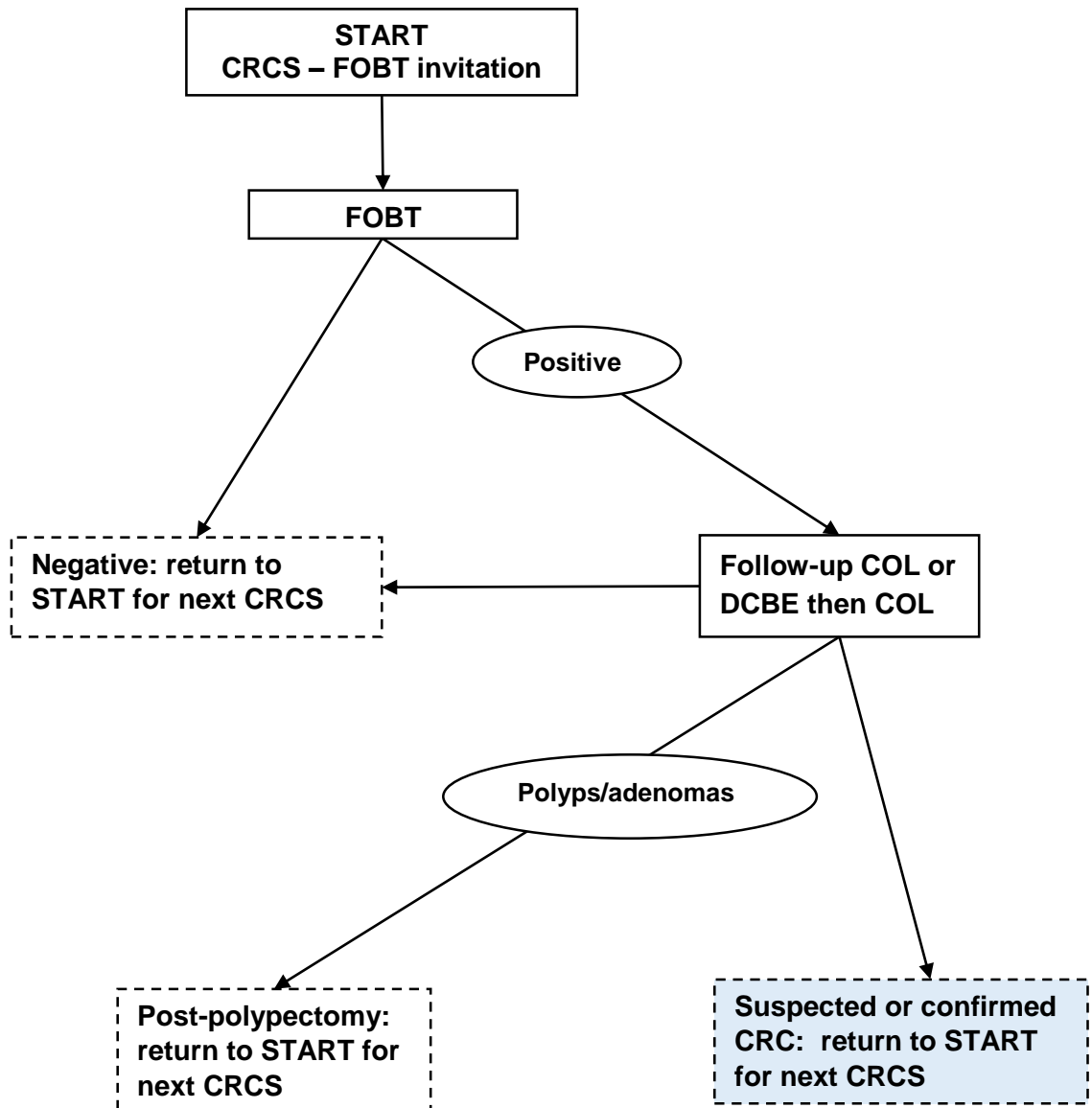

COL colonoscopy; **CRC** colorectal cancer; **CRCS** colorectal cancer screening; **DCBE** double-contrast barium enema; **FOBT** faecal occult blood test

Figure 1.7 Gaps in the current CRCS NHI

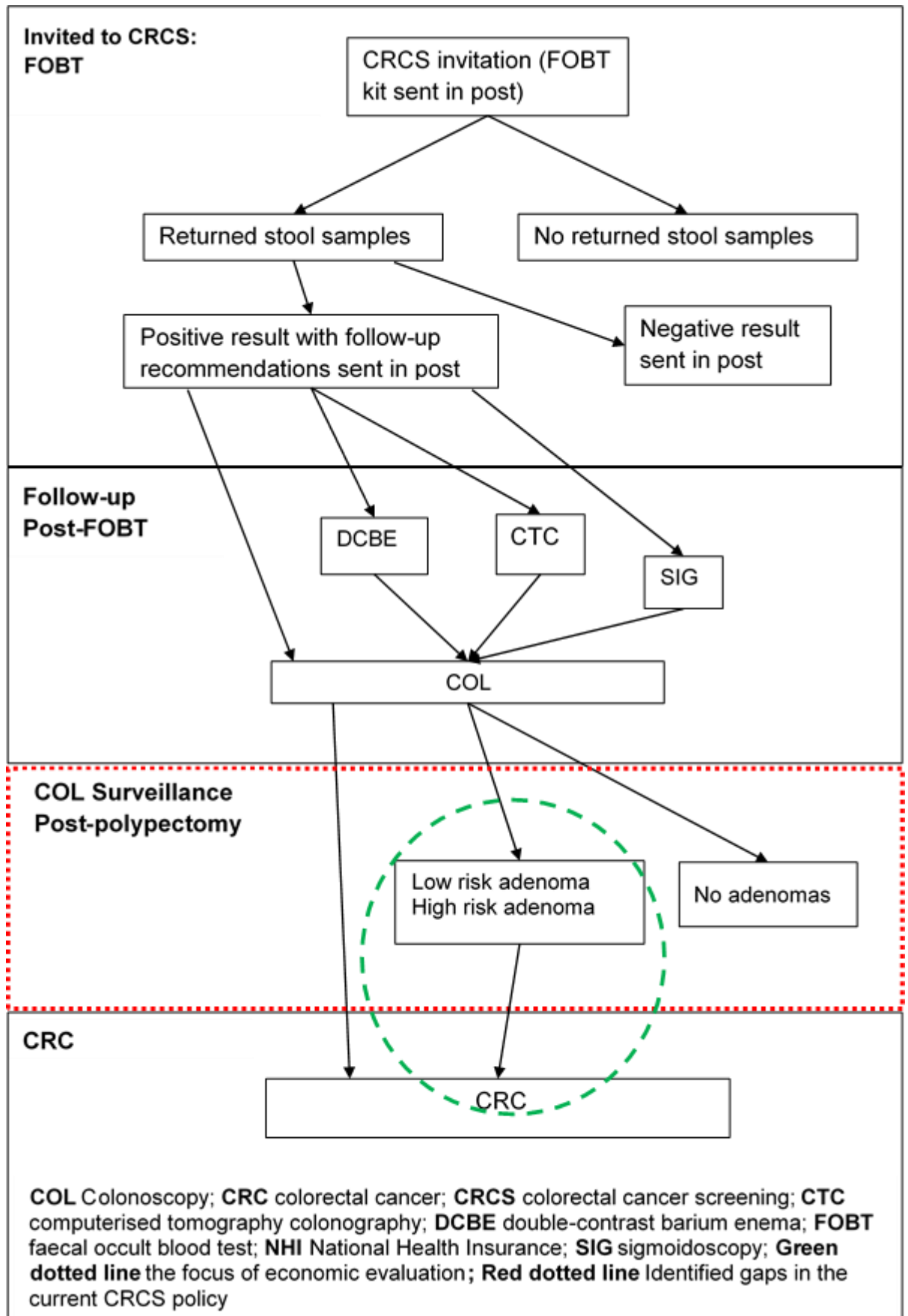

Correlation between the level of CRC disease stage at diagnosis and survival indicates that early detection and prevention of CRC through timely screening and COL surveillance of those at a high risk of developing the recurrent precursor of CRC, can reduce CRC mortality and morbidity [33, 40]. The number of adenomas is said to be positively correlated with the increased risk of advanced neoplasia [69].

Index COL, defined as the most recent COL performed by an experienced specialist colonoscopist, is performed in order to remove detected polyps/adenomas and to establish risk status [24, 67, 69, 70]. Adenomas are categorised by size, type (pathology test results) and the number present [40, 67]. Based on the findings from an index COL, people with 3 or more adenomas, any adenoma > 10 mm, or any tubulovillous or villous adenoma(s), any adenoma(s) with high-grade dysplasia or any serrated polyp(s) larger than 10 mm are considered to be at a high risk of developing subsequent advanced adenomas and/or CRC, therefore COL surveillance is recommended 3 years after polypectomy in the first COL surveillance guideline in Korea [40].

Clinicians/practitioners recommended a follow-up COL according to the risk stratification based on the findings from the index COL [24, 40]. Repeated COLs within the CRCS or within NHI are reimbursed by current NHIS regardless of the interval between COLs because there is no clear guideline or ceiling set within the current reimbursement for CRCS. A COL performed outside CRCS in the NHI is defined as health care service utilisation, HCSU). In addition, each reimbursement claim of COL is treated as a separate episode in the current reimbursement and review of CRCS. Multi-society guidelines recommend COL surveillance 3 years after the index COL in the HR group and 5 years in the LR

group [24]. COL surveillance at a 3 year interval is recommended after removal of adenomas smaller than 10 mm, 1 year after removal of adenomas greater than 10 mm or more than one [15]. However, such recommendations lack the details. What should be done if there are 2 or 3 consecutive negative findings from COL surveillance in the HR group? Or will the assigned risk status based on the index COL remain unchanged? Atkins and Saunders [39] outlined the required steps of down-grading and ceasing COL surveillance post-polypectomy.

Notably, more than 50% of practitioners did not follow recommended COL surveillance or chose different guidelines in a survey [71, 72]. This suggests that the state-regulated reimbursement of COL is not agreed with clinicians/practitioners, but presenting clear costs and consequences of COL surveillance in the form of economic evaluation would probably facilitate convincing stakeholders [73]. Koreans are exposed to opportunistic screening, and multiple national health checks and screening programmes which may provide further opportunities of having COL repeated. Repeated and duplicated COL become a barrier to establishing an accurate index COL that acts as the basis of risk stratification for COL surveillance [24, 74]. There is a number of CRCS guidelines but the COL surveillance guidelines remain limited. Discrepancies between CRCS guidelines and the implementation of guidelines were widespread [75]. CRCS programmes are offered in the USA, Canada, Australia, Europe, Japan and Korea, but COL surveillance is only recommended in the NHS UK and in the US [76].

Table 1.7 summarises the discrepancies in the risk stratifications of COL findings and the recommendations for COL surveillance post-polypectomy in CRCS, NHI in Korea.

Table 1.7 Discrepancies in the risk stratification of adenomas and identified gaps in the recommendations and current practice

Low risk	High risk	COL interval (year) post-polypectomy	References
Without any high-risk findings at index COL	3 or more adenomas or any adenoma larger than 10 mm or any tubulovillous or villous adenoma or any adenoma with HGD or any serrated polyps larger than 10 mm	5LR3HR (5 years for LR, 3 years for HR)	Yang (2012) [24] Hong (2012) [67]
Not specified	In patients with alarming symptoms or with a high risk of interval cancer	5LR HR ≤5 (less than 5 years)	Lee BI (2012) [40]
Any adenomas without high risk	3 or more adenomas or adenomas > 10 mm or HGD or any tubulovillous or villous adenoma	1HR	Jung (2012) [77]
6 mm tubular adenoma or two 6 mm tubular adenomas	12 mm tubular adenoma with HGD 12 mm tubulovillous adenoma	LR ≤1 (less than 1 year) 3LR; 5LR HR≤1; 3HR; 5HR	Sohn (2014) [72]

COL colonoscopy; **HGD** high-grade dysplasia; **HR** high risk; **LR** low risk

In any screening programme potential harm should be considered in order to minimise unintended consequences such as complications of screening interventions while maximising health benefits given the limited resource [25]. Duplication of screening activities within CRCS and NHI need to be reduced to improve cost-effective use of finite health care resources [13]. User access to health care institutions has been the ongoing focus of the cancer control plan and expansion of subsidies for cancer treatments has resulted in steadily increasing resource use in the NHI [7, 19].

A better understanding of and structured management of CRCS have been suggested in order to improve the efficiency [68]. The estimated proportion of the Korean population needing COL will increase from 29% in 2010 to and 60% in

2050 [1]. Thus, careful forward planning for COL as part of CRCS is vital, training for the relevant specialists, investments for appropriate level of facilities within the budget constraints are examples that would be of high priority in Korea. Kim *et al.* (2014) suggested specific indicators should be developed for the future evaluation of CRCS including cost per CRC detected and cost per CRCS per person [52].

The benefits of CRCS can be accrued over a long period due to the long lead-time of adenoma-carcinoma, therefore CRCS should be linked to CRC treatment in order to get a fuller picture of CRCS [78, 79]. The feasibility and sustainability of NHI against the return of investment in health terms need to be reviewed without any delay [11, 13]. Although spending on CRCS has been increasing over the years, the current CRCS lacks evidence regarding the cost-effectiveness of COL surveillance, which could not only minimise clinical practice variations but also promote efficient use of scarce resources in the NHI Korea. In addition, unnecessary COL would be discouraged thus promoting best clinical practice among practitioners [52, 53, 80-82]. Furthermore, COL following a positive FOBT results continues to be reimbursed without specific restriction/caps by the NHI. Clinicians/practitioners recommend COL at different intervals with different starting ages [40, 64, 80]. The importance of COL surveillance is further emphasised through meta-analyses of evidence and the final decision on the COL surveillance interval is said to be best made by clinicians [40].

1.7 Conclusion

The NHI is characterised by the state-regulated fees for health services, predominantly for-profit health service providers and the co-payments paid for by service users in the NHI. NHIS collects data related to all health checks, NCSPs including CRCS of the population in Korea. Although a comprehensive electronic data system pools demographic and health data in the NHI, this wealth of data is not being utilised to inform the decision making process of CRCS to make the best use of resources in the NHI, Korea. Current clinical practice of CRCS is difficult to map out due to various health care service delivery and reimbursement systems including NHI and 3rd party private insurance. With the rapidly increasing health care expenditure, the government attempts to move towards evidence-informed decision-making for health care, thus the use of economic evaluation of existing CRCS and NCSPs would provide a better alternative to state-regulated cost control for the NHI in the long term [9, 83].

Recommended guidance and clinicians own practice on the follow-up COL vary markedly in the intervals of COL in the current CRCS [24, 67, 72, 74, 77]. Furthermore, there is no cost-effectiveness evidence of COL surveillance among people with confirmed colorectal adenomas in the CRCS, NHI in Korea. Given the increasing economic burden of CRC and limited resources for the provision of COL surveillance, examining the cost-effective strategies should be a logical next step. Therefore, cost-effective strategies for COL surveillance will be identified through an economic analysis in order to promote cost-effective use of resources in the early detection and prevention of CRC in CRCS NHI [68].

1.8 Aims and objectives

This study aims to identify the most cost-effective strategies, based on the best available evidence, in the COL surveillance for individuals who had confirmed adenomas in the prevention and early detection of CRC in the CRCS, NHI. During the course of this research a rare opportunity arose to form a collaboration with a Korean researcher, this enabled access to NHI data. The specific objectives to fulfil the main aim of this study are:

- 1) Identification of resources used in CRCS and CRC treatment, and mapping of the current clinical practice and common CRCS pathways in the prevention and early detection of CRC and the estimation of adenoma recurrence rates post-polypectomy in the CRCS, NHI – achieved by collaboration with a researcher from Korea, a cohort dataset utilising NHI reimbursement data was constructed.
- 2) Review of the relevant cost-effectiveness evidence of COL surveillance in people with colorectal adenomas – achieved by conducting a literature review of published cost-effectiveness evidence in the prevention and early detection of CRC.
- 3) Estimation of health outcomes relevant to CRCS in order to populate economic model(s)- achieved by conducting a literature review of relevant HSUVs for economic evaluation.
- 4) Identification of cost-effective strategies for COL surveillance for the prevention and early detection of CRC – achieved by developing an economic model and identifying the most cost-effective strategy of COL surveillance by utilising findings from objectives 1) to 3).

2 SHORT-TERM ANALYSIS OF COLORECTAL CANCER SCREENING IN NHI, KOREA, 2009-2012

2.1 Preamble to Research Paper I

Chapter 2 contains the identification of resources used in CRCS and CRC treatment, and a mapping of current clinical practice and common CRCS pathways in the prevention and early detection of CRC in the NHI. As highlighted in the previous chapter, although CRCS has been offered in Korea since 2004, there is no evidence on the current practice, average costs of CRCS, the breakdown of COL surveillance costs, the average costs of CRC diagnosis and the treatment of CRC in the NHI. A unique opportunity to collaborate with a Korean researcher enabled the establishment of a Korean CRC cohort, utilising NHI reimbursement data. In this research paper the current clinical practice in the CRCS is mapped out based on NHI data by using indicators for the CRCS evaluation including the cost per CRC detected using COL and the average cost of CRC treatment [52]. Subgroup analyses were carried out to estimate the adenoma recurrence rates post-polypectomy and the CRC-free survival time among people with low-risk (LR) or high-risk (HR) of developing CRC who required follow-up COL post-polypectomy (COL surveillance). Also reported were the gaps in CRCS reporting, the variations of CRC staging information collected by different institutes/organisations and the risk stratification through the analysis of the CRC cohort.

Findings from the CRC cohort analysis including the average costs of CRCS, the average costs of CRC diagnosis and the treatment of CRC, and a further breakdown of COL surveillance costs, are used to estimate expected costs and benefits of COL surveillance in CRCS, NHI (Chapter 5).

Research Paper Cover Sheet – Research Paper I

London School of Hygiene & Tropical Medicine
Keppel Street, London WC1E 7HT
www.lshtm.ac.uk

Registry
T: +44 (0)20 7299 1848
F: +44 (0)20 7299 6856
E: registry@lshtm.ac.uk

LONDON
SCHOOL of
HYGIENE
& TROPICAL
MEDICINE



RESEARCH PAPER COVER SHEET

PLEASE NOTE THAT A COVER SHEET MUST BE COMPLETED FOR EACH RESEARCH PAPER INCLUDED IN A THESIS

SECTION A- Student Details

Student	Kim Eyoung Jeong
Principal Supervisor	Professor John Cairns
Thesis Title	Cost-effective strategies in the follow-up of people with confirmed colorectal adenomas for the prevention and early detection of colorectal cancer in the National Health Insurance, South Korea

If the Research Paper has previously been published please complete Section B, if not please move to Section C

SECTION B – Paper already published

Where was the work published?	
When was the work published?	
If the work was published prior to registration for your research degree, give a brief rationale for its inclusion	
Have you retained the copyright for the work?*	Choose an item. Was the work subject to academic peer review?

If yes, please attach evidence of retention. If no, or if the work is being included in its published format, please attach evidence of permission from the copyright holder (publisher or other author) to include this work.

SECTION C – Prepared for publication, but not yet published

Where the work intended to be published?	Peer-review journal (to be decided)
Please list the paper's authors in the intended authorship order:	Kim Jeong, Heeyoung Lee, John Cairns
Stage of publication	Not yet submitted

SECTION D – Multi-authored work

For multi-authored work, give full details of your role in the research included in the paper and in the preparation of the paper. (Attach a further sheet if necessary)	See next page.
--	----------------

Student Signature: _____ Date: _____
Supervisor Signature: _____ Date: _____

Title: Short-term analysis of colorectal cancer screening in South Korea, 2009-2012

Authors: Kim Jeong¹, Heeyoung Lee², John Cairns¹

Affiliations:

¹Department of Health Services Research and Policy, London School of Hygiene and Tropical Medicine, London, UK

²Seoul National University Bundang Hospital, Gyeonggi-do, Korea

Candidate's contribution: Under the guidance of John Cairns (JC), the study concept was designed by the candidate (KJ). Access to NHI data and Ethics approval were obtained by Heeyoung Lee (HL). The building of the CRC cohort data and statistical analyses were undertaken by KJ by discussion with HL. Data linkage was performed by HL. Mapping out CRCS pathways and its validation were undertaken by KJ and HL. JC gave advice during the course of the study conceptualisation, analysis and validation. The first draft of the manuscript was written by KJ.

2.2 Research Paper I Short-term analysis of colorectal cancer screening in South Korea, 2009-2012

2.2.1 Abstract

As a single purchaser of health services in Korea, the National Health Insurance Service (NHIS) manages the health care service costs and the reimbursement of colorectal cancer screening (CRCS) in the National Health Insurance (NHI), Korea. There has been only limited evaluation of the costs and benefits of CRCS despite the considerable resources committed for over a decade. The aim of this study is to provide information for economic evaluation of CRCS. Specific objectives include the identification of common pathways in CRCS with relevant resources used in the NHI. A retrospective cohort study was constructed by utilising reimbursement data from the NHI, the single public purchaser of health services, 2009-2012. Four CRCS pathways were mapped including CRCS only, HSCU (health care service utilisation within the NHI) only, non-compliant to CRCS (NC) and CRCS combined with HCSU. The highest average cost of CRC detection was in the CRCS only group and lowest in the NC group. The highest average cost of CRC treatment was in the NC group. Estimates of adenoma recurrence rates post-polypectomy were derived from the subgroup analysis, which can inform the future economic evaluation. This short-term analysis is the first study utilising the detailed NHI data including costs and benefits of CRCS and the utilisation of relevant health care services at a Korean population level from the NHI perspective. From our knowledge, this short-term analysis of CRCS is the first study to highlight differences between CRCS reimbursement policy

and the current clinical practice by utilising the detailed NHI data at a population level in Korea.

Further studies concerning risk-based CRC-free survival post-polypectomy utilising CRCS and NHI data are warranted to inform decision making in the CRCS NHI.

KEY WORDS

Colorectal cancer; screening; surveillance; colonoscopy; adenoma

2.2.2 Introduction

CRC is the third most common cancer in Korea [48]. The National Health Insurance (NHI) is the single public purchaser of health services covering 97.1% of the population [17]. The remaining 2.9% of Koreans with below minimum income levels are covered by the Medical Aid Programme (MAP). NHI and MAP are operationalised by the National Health Insurance Service (NHIS) [17].

CRC screening (CRCS) as part of the National Cancer Screening Programmes (NCSP) was first implemented in 2004 for MAP beneficiaries and was gradually rolled out to Koreans aged 50 years and older [8]. Previously, people who were 50 years and older were invited to a biennial FOBT [8, 52]. Colonoscopy (COL) or double-contrast barium enema (DCBE) followed by COL are recommended follow-up tests after a positive FOBT result [31]. However, evidence indicated that FOBT and COL are not always carried out as per CRCS policy and there are many opportunistic screening programmes outside CRCS that are not insured by NHI [13, 84].

Despite the huge amount of efforts and resources being spent on CRCS over a decade, the need for structured follow-up strategies from CRCS remains unmet despite gaps reported by several studies [11, 52, 80, 81]. Clinicians and experts have highlighted the costs per CRC detected and costs per early CRC detected as priorities in the evaluation of CRCS [52].

The cost of COL surveillance, of diagnosis and of treatment of CRC are crucial parameters to inform an economic evaluation; however, such information is not readily available in the CRCS and NHI. The aim of this study was to elaborate and exemplify a pragmatic approach to estimate costs of COL surveillance, diagnosis and treatment of CRC based on reimbursement data from the NHI,

2009-2012 CRC cohort. The findings from this analysis would provide evidence for the cost-utility analysis of COL surveillance for people with confirmed colorectal adenomas in the CRCS, from the NHI perspective in Korea (Chapter 5). The main objectives were to: 1) provide costing information of CRCS and COL surveillance and the costs of CRC diagnosis and CRC treatments by utilising CRCS reimbursement data in the NHI; 2) to map common pathways in CRCS.

The primary purpose of this short-term analysis was to provide costing information for the COL surveillance in this thesis and future economic evaluation of CRCS by utilising CRCS reimbursement data in the NHI. In addition, this study aimed to map out common pathways in CRCS with relevant resources by utilising reimbursement NHI data at a Korean population level for the period 2009-2012. Based on the pathways identified, the secondary endpoints included CRCS compliance rates and the estimation of the total costs of diagnosis and treatment of CRC [52]. People with confirmed colorectal adenomas who required COL surveillance were further considered in a subgroup analysis in order to estimate the adenoma recurrence rates post-polypectomy according to risk status and CRC-free survival post-polypectomy for the economic evaluation of COL surveillance in the CRCS.

2.2.3 Methods

Ethics approval

This study and the waiver of the requirement to obtain informed consent were approved by the Institutional Review Board (IRB) of Seoul National University Bundang Hospital (IRB No. X-1411/276-902, see Appendix Figure A2.1).

CRC cohort data and NHIS routine data collection

The CRC cohort comprised 6,658,551 Korean individuals aged 50 and over with no previous history of CRC or current CRC on 1 January 2009. People with previous or current CRC were identified and excluded through tracking CRC related ICD-10 codes and Special Cancer Fund V193 [85]. Index COL, defined as the most recent COL performed by an experienced specialist colonoscopist, was performed as part of follow-up testing for those with a positive FOBT result in the CRCS. In addition, people who had a COL procedure in 2007-2008 were also excluded from the CRC cohort 2009-2012. NHIS routinely collects data associated with NCSPs. NHIS collects NHI contributions (premiums) based on reported household income levels [31]. NHI pays health care service providers based on the submitted reimbursement forms. Follow-up COL results are recorded as normal, inflammatory or hyperplastic polyps, low grade adenoma/dysplasia, high grade adenoma/dysplasia, suspected CRC or CRC (see Appendix Figure A2.2) [8]. These routinely collected data and CRCS results were anonymised and linked with the relevant health care service utilisation (HCSU) for the NHIS 2009-2012 (see Figure 2.1).

Direct costs were considered including NHI reimbursed items, co-payments made by service users for the NHI insured items and other health service usages for non-CRC related conditions in the NHI. The analysis of cost was from the best use of health care resources among different COL surveillance strategies in the CRCS, Korea. Direct costs including NHI reimbursements, co-payments made by service users for NHI insured items in all mapped pathways including HCSU and NC from the perspective of providing health care services. CRCS costs included the costs of COL and pathology in the case of adenoma. CRC diagnostic costs

were costs incurred from the date of 'suspected CRC' to the day before the first CRC treatment. Active CRC treatment costs included outpatient clinic visits, hospital admission episodes and visits to the emergency department. CRC treatment costs were calculated from the first day of CRC treatment to 6 months including any health care service utilised by individuals with CRC diagnosis. CRC follow-up costs included the costs of any health care service utilised by individuals with a CRC diagnosis in the period from day 1 after the CRC treatment to 6 months.

Figure 2.1 CRC cohort, 2009-2012

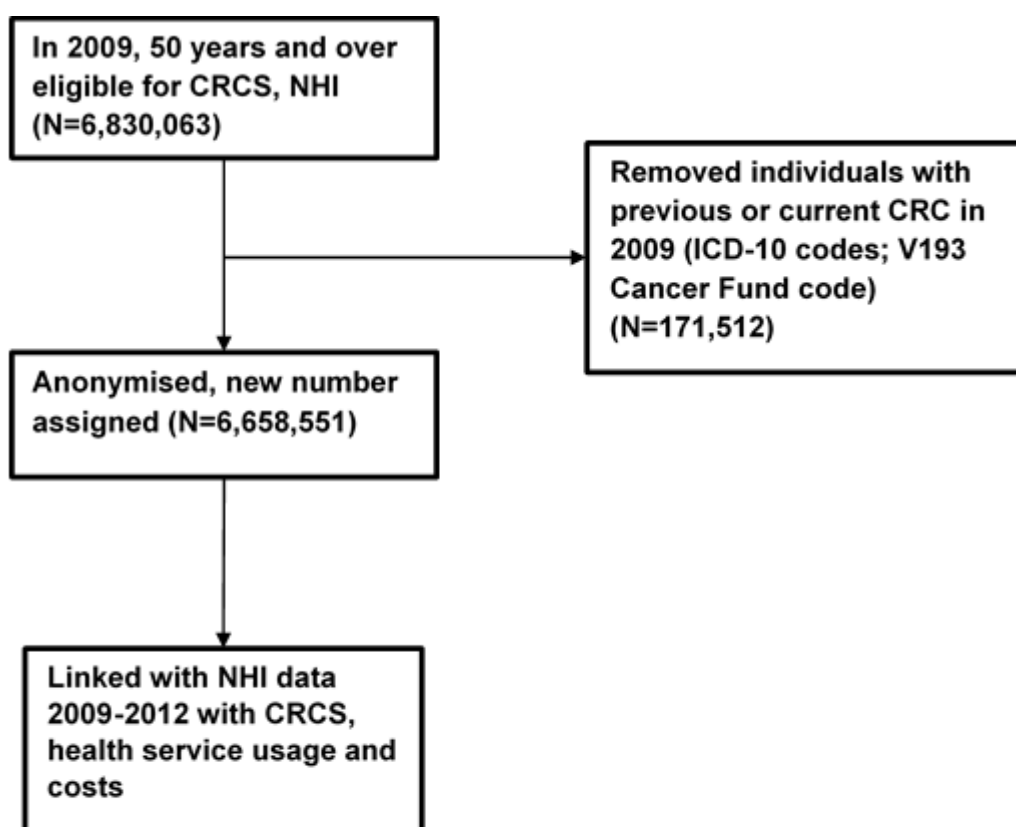

CRC colorectal cancer; **CRCS** colorectal cancer screening; **ICD** International Statistical Classification of Diseases and related Health Problems; **NHI** National Health Insurance

Definitions and assessment of risk variables

Adenomas found during any COL surveillance after index COL are defined as recurrent adenomas. The findings of the index COL were stratified according to the number and size of adenomas and histology results. The size of adenomas (mm) detected was recorded in the CRCS. However, the number of adenomas removed at the index or follow-up COL is not currently reported (see Appendix Figure A2.2). Therefore, the number of biopsies, derived from the number of histology and the number of biopsy results, was used as a proxy for the number of polyps/adenomas removed during the COL surveillance. Reported histology results included low- or high-grade dysplasia from adenoma biopsies. The number/size and the degree of dysplasia of adenomas were used to decide the risk status of the individual at the index COL post-polypectomy [24, 39, 40].

Statistical analysis

Descriptive analysis was carried out to understand the cohort characteristics and to map out pathways. Kaplan Meier survival analysis and a range of functions for the model were estimated to examine the cumulative risk of developing CRC post-polypectomy (subgroup COL surveillance) in order to extrapolate the risk of developing CRC beyond the short-term follow-up period [86]. Data analysis was performed using STATA®/SE14.

2.2.4 Results

Characteristics of the CRC cohort and compliance to CRCS

In 2009, of 6,658,551 eligible individuals for CRCS, the mean age was 60.45 years (SD 9.52, male 47.2%). The majority were female in all age groups (except <55), and the number of female individuals was more than twice as many as male in the 80 year and older age groups (see Table 2.1).

Table 2.1 Characteristics of CRC cohort (N=6,658,551)

	Male	Female
	3,143,697 (47.21%)	3,514,854 (52.79%)
Mean age (SD)	60.45 (\pm 9.52)	
Age (years)		
50 \leq age <55	1,164,699	1,143,797
55 \leq age <60	642,243	660,810
60 \leq age <65	435,025	444,536
65 \leq age <70	446,766	521,877
70 \leq age <75	234,998	311,948
75 \leq age <80	142,616	249,589
80 \leq age < 85	46,863	101,585
85 < age	30,487	80,712

CRC colorectal cancer; **SD** standard deviation

Of the 6,658,551 individuals who were eligible for CRCS in 2009, approximately 29.5% were compliant with the FOBT invitation, and 6.16% of participants had positive FOBT results. Participation in the follow-up test for those with positive FOBT remained between 35-45% during 2009-2012 (see Table 2.2). Everyone in the CRC cohort (starting from 1 January 2009) was eligible for CRCS in 2009 and 2011 under the biennial CRCS policy, and again in 2012 following the introduction of the annual invitation policy as a consequence of the move from

biennial to annual CRCS implemented from 2012 [87]. Compliance rates to biennial FOBT invitation was approximately 29-31% in 2009 and 2011, and a lower compliance rate (17.1%) in 2012, the first year of annual FOBT (see Table 2.2).

Table 2.2 CRCS compliance CRC cohort, 2009 and 2011-2012

Description [interval of FOBT within CRCS policy]	*2009 [biennial]	*2011 [biennial]	‡2012 [annual]
a) Number (% of CRC cohort) of people who had the FOBT	1,963,874 (29.49%)	2,080,837 (31.25%)	1,138,299 (17.10%)
b) From those who had the FOBT in (a), the number (%) of individual positive FOBT results	121,131 (6.16%)	128,816 (6.19%)	66,489 (5.84%)
c) From those with a positive FOBT result in (b), the number of people compliant to follow-up	53,992 (44.57%)	45,336 (35.19%)	25,059 (37.69%)

CRCS colorectal cancer; **CRCS** colorectal cancer screening; **FOBT** faecal occult blood test; *Biennial CRCS offered until 2011, changed to annual CRCS from ‡2012

Mapping common pathways in CRCS

Four common pathways (CRCS, HCSU, NC (non-compliant), CRCS combined with HCSU) were identified when considering compliance, reported results, additional tests outside CRCS within NHI and CRC incidence as presented in Table 2.3 and Figure 2.2. Further detailed steps taken to mapping CRCS pathways are reported in Appendix Figure A2.3 and Appendix Table A2.1.

Results highlight varying pathways outside the current CRCS policy. Further COLs were performed after a FOBT positive result indicating possible duplication of COLs in and outside the CRCS and NHI.

Table 2.3 Mapping common pathways in the CRCS

Description	Pathway
Compliant to CRCS (FOBT positive then follow-up test (COL or DCBE then COL)) (CRC detected)	CRCS only
Compliant to CRCS (FOBT negative), then CRC treatments after *90 days (missed CRC)	CRCS only
Compliant to CRCS (FOBT positive then COL negative), then CRC treatment after *90 days (missed CRC)	CRCS only
Compliant to CRCS (FOBT positive then follow-up test negative, no CRC)	CRCS only
NC to CRCS and xTests, then CRC treatments received (CRC)	HCSU only
NC to CRCS and xTests, and no CRC	HCSU only
NC and CRC treatments received	NC
NC and no CRC treatment received (no CRC)	NC
Compliant to CRCS FOBT positive and xTest (COL) then CRC treatments	CRCS combined with HCSU
Compliant to CRCS (FOBT positive and follow-up test positive) and xTest (COL) then CRC treatment	CRCS combined with HCSU
Compliant to CRCS (FOBT positive), then HCSU (no CRC)	CRCS combined with HCSU
Compliant to CRCS (FOBT negative), then CRC treatments (missed CRC)	CRCS combined with HCSU
Compliant to CRCS, FOBT negative, then HCSU (no CRC)	CRCS combined with HCSU

COL colonoscopy; **CRC** colorectal cancer; **CRCS** colorectal cancer screening; **DCBE** double-contrast barium enema; **FOBT** faecal occult blood test; **Follow-up test** COL or DCBE then COL; **HCSU** health care service utilisation outside the CRCS but still within NHI when xTests were performed; **NC** non-compliant to CRCS; **xTests** screening tests (FOBT, COL, or DCBE) performed outside the CRCS within NHI; ***90 days** [52]

Figure 2.2 Identified common pathways in CRCS in 2009

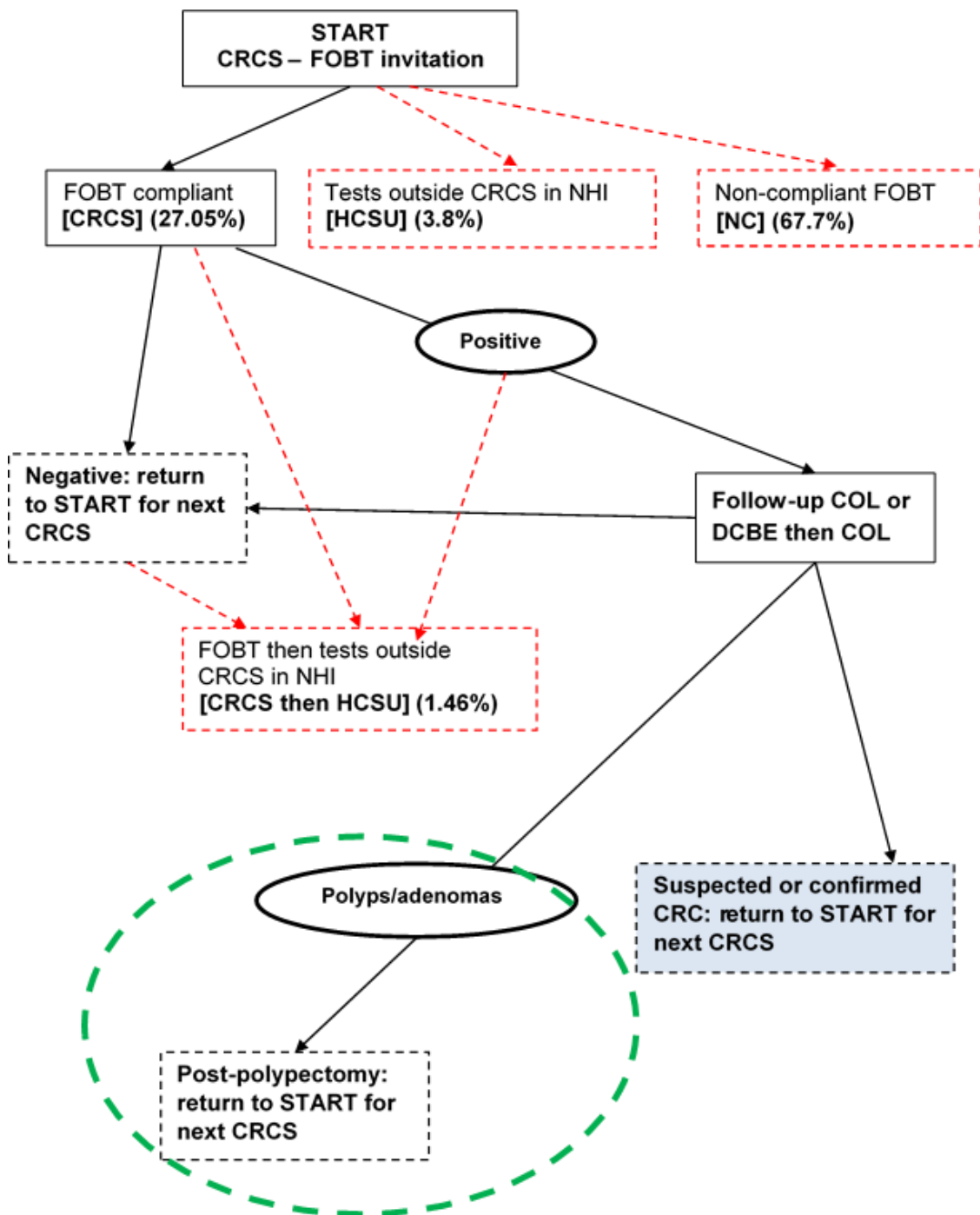

COL colonoscopy; CRC colorectal cancer; CRCS colorectal cancer screening programme; DCBE double-contrast barium enema; FOBT faecal occult blood test; **Black solid arrow** (→) current CRCS pathway; **Green dotted circle** the focus of economic analysis; HCSU health care service utilisation; NC non-compliant (to CRCS); **Red dotted arrows** mapped pathways outside the current CRCS

Identified common pathways in the CRCS and the corresponding numbers of individuals in each pathway from 2009 to 2012 are presented in Figure 2.3.

Figure 2.3. Mapped common pathways in the CRCS in the CRC cohort, 2009-2012

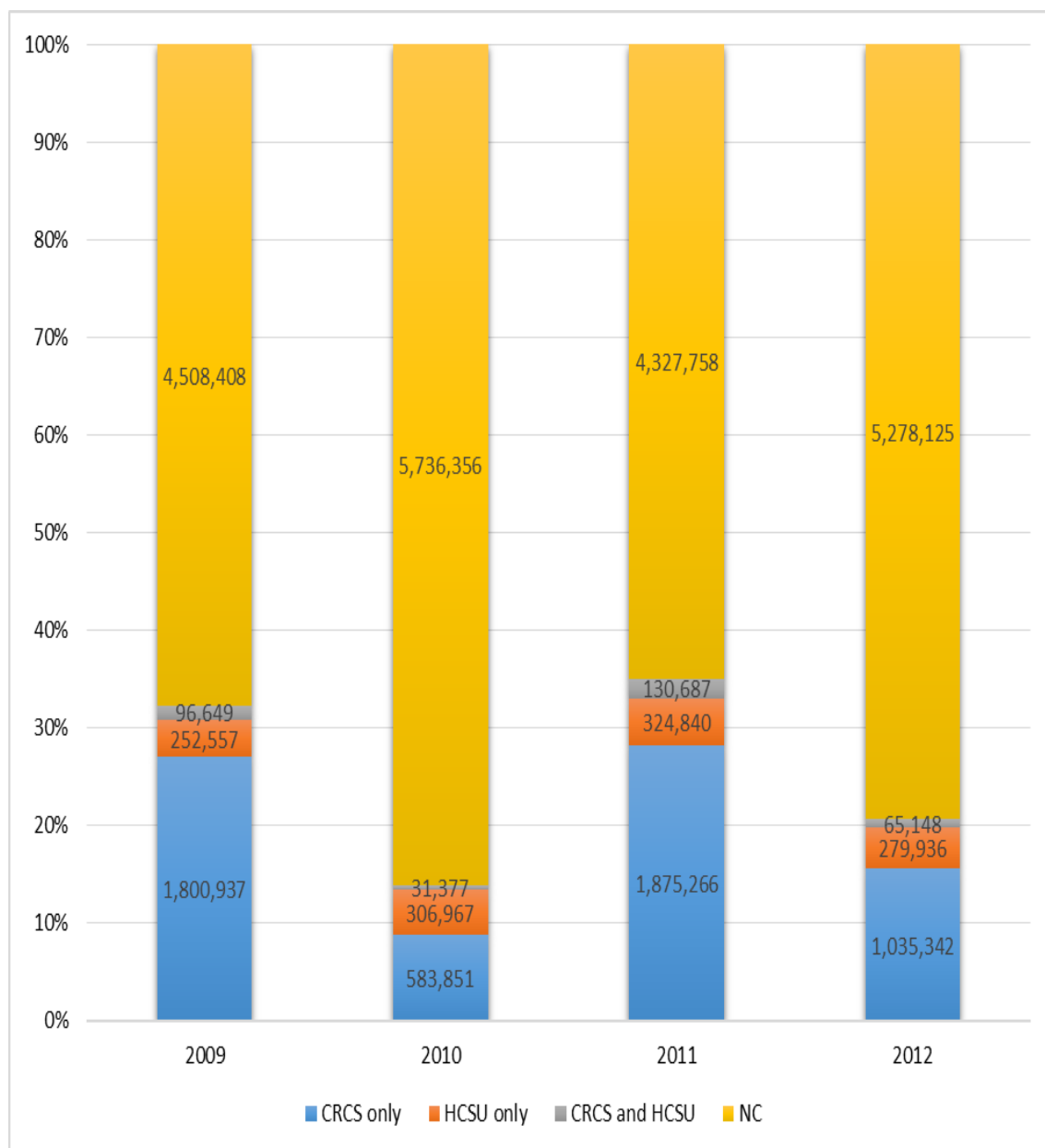

CRCS Colorectal cancer; **HCSU** Health care service utilisation outside CRCS within NHI; **CRCS** colorectal cancer screening; **NC** Non-compliant to CRCS

Costs of diagnosis and treatment of CRC per CRCS pathway

The highest average cost of new CRC diagnosis was in the CRCS only group and lowest in the NC group in 2009. Estimated average costs of CRC diagnosis per pathway are presented in Tables 2.4.1-2.4.2. For a summary of unit costs associated COL surveillance and CRC diagnosis in the CRCS see Table 2.4.3.

Table 2.4.1 Average costs of CRC diagnosis per pathway

(Unit: KRW; KRW 1,000=GBP 0.56)

Pathway	Number of new CRC	Average costs of CRC diagnosis	Min	Max	SD	Cost per CRC diagnosis
CRCS only	1,203	18,251,733,608	143,504	37,353,240	992	15,171,848
HCSU only	4,842	16,701,708,000	123,435	31,243,434	935	3,449,341
NC	1,031	124,596,350	103,524	29,235,354	933	120,850
CRCS combined with HCSU	1,232	8,541,531,425	124,354	32,343,258	774	6,933,061

CRC colorectal cancer; **CRCS** colorectal cancer screening in the National Health Insurance (NHI); **HCSU** Health care service utilisation outside CRCS within NHI; **KRW** Korean Won; **GBP** Great British Pound; **NC** Non-compliant to CRCS; **SD** standard deviation

Table 2.4.2 Breakdown - average costs of CRC diagnosis per pathway

(Unit: KRW; KRW 1,000=GBP 0.56)

Pathway	Breakdown	Unit cost				Number			
		Average	min	max	SD	Average	min	max	SD
CRCS only	Outpatient clinic visits	39133	12343	93212	87	3.9	1	7	1.3
	Treatments including surgical procedures	86232	0	423241	123.2	3.4	0	8	2.1
	Diagnostic tests	623433	0	1423146	231.5	4.1	1	12	3.4
	Diagnostics: imaging technologies	1931740	0	9514319	214.4	6.3	1	10	1.4
HCSU only	Outpatient clinic visits	31234	12381	53432	76.5	2.4	1	6	1.5
	Treatments including surgical procedures	43432	0	194312	95.6	2.3	0	13	3.1
	Diagnostic tests	234353	0	643243	234.1	2.9	1	22	4.2
	Diagnostics: imaging technologies	632893	0	8314324	423.2	4.1	1	34	1.3
NC	Outpatient clinic visits	12323	11213	54324	54.6	1.8	1	14	5.2
	Treatments including surgical procedures	13434	0	564323	434.1	1.6	0	6	2.1
	Diagnostic tests	23243	0	332149	234.2	1.3	1	23	3.5
	Diagnostics: imaging technologies	39131	0	8599513	1353.1	1.2	0	16	2.4
CRCS combined with HCSU	Outpatient clinic visits	24356	9421	64342	132.1	2.3	1	27	5.6
	Treatments including surgical procedures	23453	0	732143	323.5	3.5	0	13	2.4
	Diagnostic tests	873221	0	1415314	231.3	3.2	1	23	5.2
	Diagnostics: imaging technologies	975768	0	6452341	435.2	4.1	1	19	4.1

CRCS colorectal cancer; **CRCS** colorectal cancer screening in the National Health Insurance (NHI); **HCSU** Health care service utilisation outside CRCS within NHI; **KRW** Korean Won; **GBP** Great British Pound; **NC** Non-compliant to CRCS; **SD** standard deviation

Table 2.4.3 Summary of unit costs associated COL surveillance and CRC diagnosis in the CRCS

(Unit: KRW; KRW 1,000=GBP 0.56)

Description	Reimbursement NHI (2015) [8]
COL	74,240
Bowel preparation for COL	8,400
Biopsy during COL	12,740
Pathology	
1-3 pieces	20,390
4-6 pieces	27,470
7-9 pieces	34,560
10-12 pieces	42,530
13 and more	49,620
Outpatient clinic visits for consultation	9,479
Histopathology	40,437
Routine blood tests, complete blood count with platelet, chemistry and CEA	16,255
Colonoscopy repeated	74,240
PET-CT when metastasis is suspected	260,135
Abdomen (MRI)	277,018
Bone scan	76,062
Ultrasound sonography	44,120

CEA carcinoembryonic antigen; **COL** colonoscopy; **CRC** colorectal cancer; **CT** computed tomography; **GBP** Great British pound; **KRW** Korean Won; **MRI** magnetic resonance imaging; **PET** position emission tomography

Estimated average costs of CRCS treatment was highest in the HCSU group followed by the CRCS combination with HCSU group. Details of recommended chemotherapy agents for CRC treatment, treatment costs and radiation costs of CRC are summarised in Table 2.5.1. Average treatment costs per CRC pathway and the breakdown of treatment costs per pathway are presented in Tables 2.5.2-2.5.3.

Table 2.5.1 Summary costs of chemotherapy and radiotherapy for CRC in the NHI (NHIS 2015)

(Unit: KRW; KRW 1,000=GBP 0.56)

NHI Code	Description	Average cost
KK 153, KK154	Chemotherapy Administration-Continuous Intravenous	4,170
HE427, HE 427001, HE427006, HE427007, HE427300, HE427306, HE427307	Abdomen MRI (limited) in deciding therapeutic range and location of radiotherapy	86,605
Q2671, Q2672, Q2673, Q2679, Q2680, Q2921-Q2927	Surgeries relevant to CRC treatment: total colectomy, colectomy – segmental resection, rectal and sigmoid resection, intestinal anastomosis, hemi-colectomy, colectomy with proximal colostomy and distal stump, colonoscopic operation of colonic tumor-mucosal resection and submucosal resection	373,038
L01010101	Intravenous general anaesthesia	62,159
HD051-HD056	Teletherapy	28,378
HD057-HD059	Rotational irradiation	38,845
HD061	3-dimensional conformal therapy	152,490
HD071-HD073	Unsealed sources	36,265
HD080-HD088	Brachytherapy	2,097,480
HD091-HD092	Total body irradiation	233,060
HD093	Total skin electron beam therapy	403,665
HD110	Fractionated stereotactic radiotherapy	547,915
HD111, HD112, HD212	Body stereotactic radiosurgery	529,565
HD121	Proton therapy	513,235
HZ271	Intensity modulated radiation therapy	297,645

CRC colorectal cancer; **KRW** Korean Won; **GBP** Great British pound; **MRI** magnetic resonance imaging

Table 2.5.2 Average treatment costs of CRC per pathway

(Unit: KRW; KRW 1,000=GBP 0.56)

Pathway	Number of new CRC	Average costs of CRC treatment	Min	Max	SD	Cost per CRC treatment
CRCS only	1,203	1,306,587,293	365,154	8,561,871	945	1,086,107
HCSU only	4,842	15,197,271,881	410,587	9,515,847	892	3,138,635
NC	1,031	124,596,350	298,515	7,920,518	958	120,850
CRCS combined with HCSU	1,232	1,971,024,554	358,154	8,154,955	934	1,599,858

CRC colorectal cancer; **CRCS** colorectal cancer screening in the National Health Insurance (NHI); **GBP** Great British Pound; **HCSU** Health care service utilisation outside CRCS within NHI; **KRW** Korean Won; **NC** Non-compliant to CRCS; **SD** standard deviation

Table 2.5.3 Breakdown - Average treatment costs of CRC per pathway

Pathway	Breakdown	Unit KRW (KRW 1,000=GBP 0.56)				Number			
		Average	min	max	SD	Average	min	max	SD
CRCS (Colorectal Cancer Screening in the National Health Insurance (NHI)) only	Outpatient: clinic visits	18,321	9,123	43,213	91.2	2.6	1	14	5.4
	Inpatient stay: diet, single-room	29,334	0	312,411	231.3	2.5	1	21	5.9
	Medications	32,321	0	534,123	217.1	2.6	1	32	9.4
	Infusions, injections	23,432	0	335,153	951.2	2.3	1	31	6.8
	Anaesthetics for surgical procedures	32,491	0	321,215	321.5	1.5	1	5	3.5
	Care, physiotherapy	21,343	0	94,342	343.7	1.6	1	32	7.5
	Surgical procedures	437,598	0	1,542,452	832.9	1.2	1	18	7.8
	Diagnosis: blood tests, biopsies	76,231	0	150,231	231.1	1.9	1	25	6.2
	Diagnostics and therapeutics using imaging technologies	32,334	0	53,312	143.5	2.3	1	21	9.9
HCSU (Health Care Service Utilisation outside CRCS in the NHI) only	Outpatient: clinic visits	35,123	11,232	41,321	87.1	4.5	1	16	5.8
	Inpatient stay: diet, single-room	32,143	0	432,159	214.2	3.2	1	23	6.1
	Medications	54,321	0	832,141	256.1	2.9	1	29	10.4
	Infusions, injections	32,459	0	589,312	732.1	2.7	1	28	8.2
	Anaesthetics for surgical procedures	37,432	0	736,414	431.8	3.1	1	8	4.2
	Care, physiotherapy	42,532	0	143,115	531.2	4.3	1	23	6.9
	Surgical procedures	1,018,431	0	5,341,233	873.2	2.4	1	19	8.2
	Diagnosis: blood tests, biopsies	91,420	0	913,213	321.5	1.8	1	23	5.9
	Diagnostics and therapeutics using imaging technologies	54,123	0	154,121	43.2	2.5	1	21	10.5
NC (Non-Compliant to CRCS)	Outpatient: clinic visits	13,212	8,321	98,321	76.5	1.2	1	14	6.1
	Inpatient stay: diet, single-room	10,231	0	94,155	398.2	1.3	1	12	9.1
	Medications	8,434	0	73,211	743.1	1.1	1	32	13.4
	Infusions, injections	9,431	0	31,412	219.5	1.3	1	22	6.9
	Anaesthetics for surgical procedures	9,424	0	42,131	532.1	1.1	1	5	4.2
	Care, physiotherapy	12,322	0	213,145	313.3	1.1	1	22	9.1
	Surgical procedures	18,190	0	1,593,132	985.8	1.1	1	18	7.9
	Diagnosis: blood tests, biopsies	11,321	0	51,321	321.3	1.4	1	22	8.7
	Diagnostics and therapeutics using imaging technologies	9,435	0	59,321	431.4	1.1	1	20	15.1
CRCS combined with HCSU	Outpatient: clinic visits	28,311	14,232	421,321	98.4	2.8	1	12	9.4
	Inpatient stay: diet, single-room	32,421	0	553,241	184.4	2.4	1	15	7.4
	Medications	34,542	0	431,951	315.6	2.5	1	31	16.3
	Infusions, injections	42,532	0	983,232	643.1	2.6	1	22	8.3
	Anaesthetics for surgical procedures	31,342	0	873,214	315.6	1.7	1	6	8.5
	Care, physiotherapy	28,323	0	423,124	458.3	1.9	1	21	8.0
	Surgical procedures	659,436	0	7,433,151	873.3	1.3	1	19	6.3
	Diagnosis: blood tests, biopsies	87,321	0	983,123	74.3	1.7	1	21	5.3
	Diagnostics and therapeutics using imaging technologies	53,212	0	632,141	439.5	2.5	1	23	15.8

CRCS colorectal cancer; GBP Great British Pound; KRW Korean Won; SD standard deviation

Subgroup analysis - COL surveillance post-polypectomy

Of the four identified pathways, there was a group of people who required regular follow-up post-polypectomy (COL surveillance; n=131,422) as part of the CRCS pathway based on findings from FOBT. The COL surveillance group (marked by a green dotted line in the in Figure 2.2) was considered in a subgroup analysis.

The number of biopsies during the COL was submitted for the NHI reimbursement, however, the number of adenomas detected/removed per COL procedure was not recorded within the current reporting structure of the CRCS NHI. Therefore, it is assumed that the number of biopsies is positively correlated with the number of polyps/adenomas detected during COL, as the practitioners are reimbursed by the number of biopsies per COL under current CRCS, thus this assumption is reasonable (expert opinion). In addition, the reported number of biopsies during the COL is divided into 5 groups [8].

Based on the reported findings of follow-up COLs in the CRCS, the subgroup is divided into two risk groups as outlined in Table 2.6.

Table 2.6 Subgroup COL surveillance post-polypectomy (n=10,092), 2009-2012

Subgroup COL surveillance		Male 53.88%
Mean age (years, SD)		58.95 (SD 7.455)
Number of people with adenomas detected at index COL, 2009 (% of CRC cohort)	Low risk (LR)	8,832 (6.7%)
	High risk (HR)	1,260 (0.96%)

COL colonoscopy; **CRC** colorectal cancer; **HR** 4 or more adenomas/polyps or one adenoma ≥ 10 mm or high-grade adenoma/dysplasia; **LR** 1-3 adenomas < 10 mm or low-grade adenoma/dysplasia; **SD** standard deviation

Table 2.7 Reported COL findings from CRCS and risk stratification for economic model

Reported COL findings from CRCS (CRC cohort)			<i>*Approximated risk stratification for the economic model</i>
Reported size of adenomas			
<10 mm			LR
≥10 mm			HR
Reported numbers of adenomas			
Number of adenomas	Reported number of biopsies taken for pathology/ histology	Reported numbers of biopsies	
Not reported	1-3	Group 1	LR
Not reported	4-6	Group 2	HR
Not reported	7-9	Group 3	HR
Not reported	10-12	Group 4	HR
Not reported	13 or more	Group 5	HR
Reported degree of dysplasia in adenomas		LGD	LR
		HGD	HR

COL colonoscopy; **CRC cohort** short-term analysis of the CRCS in NHI, Korea, 2009-2012; **CRCS** colorectal cancer screening; **HGD** high-grade dysplasia; **HR** high risk **LGD** low-grade dysplasia; **LR** low risk; * approximated risk stratification was carried out using the CRC cohort data for the economic model in Chapter 5

Reported findings from CRCS and the approximation of risk stratification for the economic model are presented in Table 2.7. For risk stratification, the number of biopsies was assumed to be the number of adenomas considering the reimbursement would be made based on the number of biopsies reported in the CRCS (expert opinion). Table 2.8 presents adenoma recurrence post-polypectomy by risk groups

Table 2.8 Adenoma recurrence at follow-up COL by presence of adenomas at the index COL in 2009 (n=10,092), 2009-2012

	LR (n=8,832; 87.5% of subgroup) in 2009		HR (n=1,260; 12.5% of subgroup) in 2009	
	LR	HR	LR	HR
COL in 2010	85	1	6	4
COL in 2011	282	1	17	8
COL in 2012	79	3	7	3

COL colonoscopy; **HR** 4 or more adenomas/polyps or one adenoma, ≥ 10 mm or high-grade adenoma/dysplasia; **LR** 1-3 adenomas, < 10 mm or low-grade adenoma/dysplasia

Kaplan-Meier analysis was used to estimate CRC-free survival following polypectomy as presented in Figure 2.4. Clear steps are observed in the Kaplan-Meier curve that is likely to be due to the clustering of events around the scheduled COL surveillance visits. Around 76-77% of this subgroup remained alive in 2012.

Figure 2.4 Survival estimate post-polypectomy, CRC cohort 2009-2012

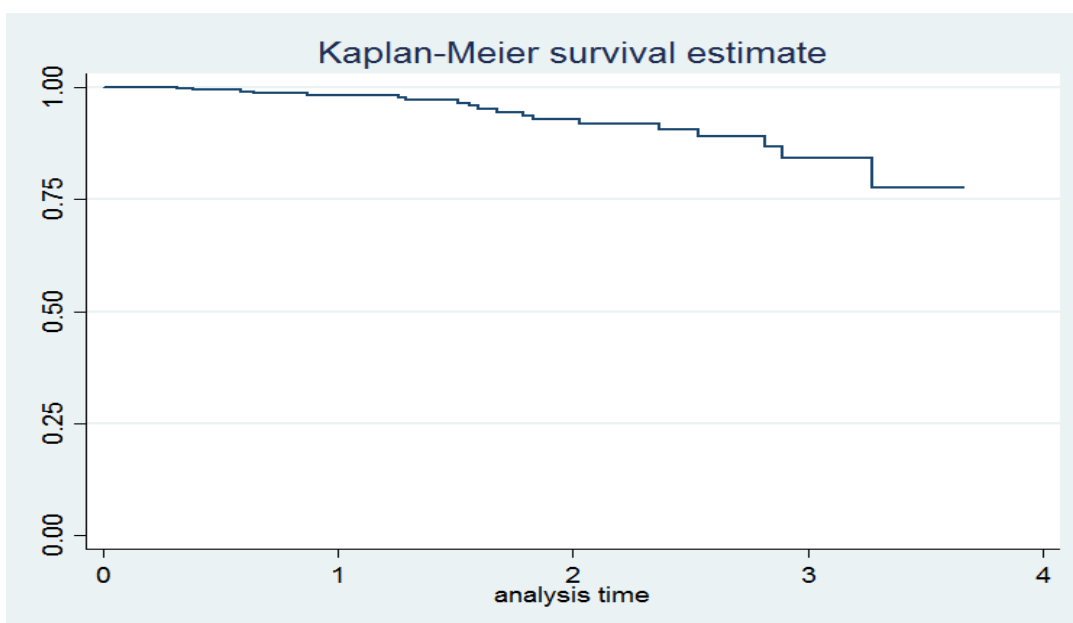

Of several methods available for undertaking extrapolation, Weibull and Gompertz functions provide the best overall fit for undertaking extrapolation beyond the data points of the COL surveillance subgroup following the Akaike information criterion (AIC) and Bayesian information criterion (BIC) test results as presented in Table 2.9 [86].

Table 2.9 AIC and BIC test results for assessing the suitability of survival models, COL surveillance subgroup

Model	AIC	BIC
Weibull	149.7909	157.5687
Exponential	160.362	164.2509
Log -normal	151.6438	159.4216
Log-logistic	150.0665	157.8442
Gompertz	149.6093	157.3871
Generalised gamma	151.5258	163.1924

AIC Akaike information criterion; **BIC** Bayesian information criterion; **COL** colonoscopy

The cumulative risk of CRC diagnosis was estimated in the subgroup with polyp/adenoma in order to extrapolate the risk of developing CRC beyond the short-term CRC cohort, 2009-2012. A survival function was estimated from CRC originating from adenoma leading to CRC death, for the subgroup, indicating approximately 80% of individuals in the subgroup would die due to CRC in the next 10 years as presented in Figure 2.5.

Figure 2.5. Extrapolated CRC-free survival curve post-polypectomy, subgroup

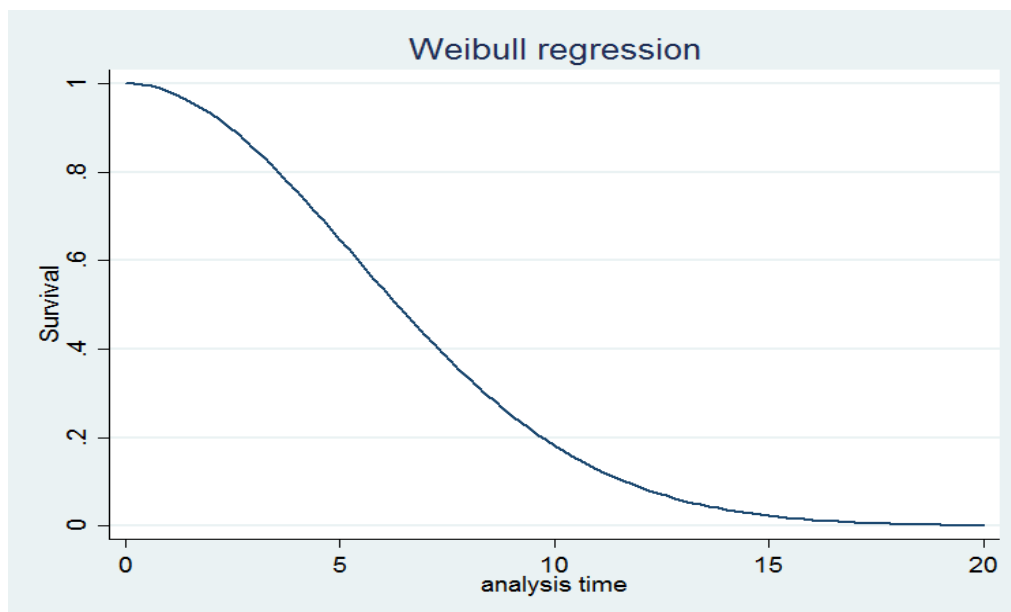

Ideally, the LR and HR follow-up COL dates at the individual level would have enabled the calculation of the transformation of adenoma into carcinoma by risk status. Estimates of adenoma recurrence rates post-polypectomy are derived from subgroup analysis; however, it is not feasible to estimate the risk of developing CRC from recurrent adenomas in different risk groups leading to CRC deaths because of the incomplete information on the timings of subsequent COL surveillance with the corresponding results in the CRC cohort.

2.2.5 Discussion

Current clinical practice can be established and the costs and benefits of CRCS can be estimated by utilising the rich CRCS dataset, thus the approaches taken in this short-term analysis can be utilised for future economic evaluation of CRCS [88]. Some insist that a randomised controlled trial (RCT) is the only way to prove the effectiveness of CRCS and the NCSP [89]. However, given the complexity of setting up randomised controlled trials related to ethical implications, this may not

be feasible, in addition, CRCS has long been implemented at a population level in Korea. Instead, a cohort comparison by creating a synthetic cohort from the abundant individual-level NHI data would be more appropriate and feasible in assessing the effectiveness of CRCS and the NCSPs [90].

Four common pathways were mapped in the CRCS based on the compliance to FOBT invitation, FOBT results, compliance to follow-up tests and their results and the different routes to CRC diagnosis using the CRC cohort data (2009-2012): CRCS only, HCSU only, CRCS combined with NHSU and NC. Improved compliance to CRCS is a priority in order to improve detection of early CRC and the subsequent reduction in CRC mortality. Findings from the CRC cohort indicate the current practice in CRCS varies substantially from the CRCS policy including HCSU only and CRCS combined with HCSU groups, and it is crucial to have consensus in the clinical guidelines and relevant reimbursement policies in CRCS, NHI.

The subgroup analysis indicated that adenomas recurrence was more frequent in the LR group compared to the HR group that might have been partly caused from the biennial CRCS changes to annual from 2011. Risk-based (LR or HR) extrapolation of CRC-free survival post-polypectomy beyond the short-term period of CRC cohort (2009-2012) was not possible due to the limited information on the dates of follow-up COLs linked to their outcomes in the subgroup. A CRC cohort with a longer-term follow-up will provide further evidence of the adenoma-carcinoma sequence and the movements between the CRC disease states, this will be crucial to improving the robustness of the results of future economic evaluations.

The consensus around the reporting of CRC stages is of paramount importance as staging determines the most appropriate treatment thus improving survival. Staging of CRC disease is reported to differ across the practitioners and relevant organisations, and thus lacks comparability [91]. There are different staging or classification of CRC including Surveillance, Epidemiology and End Results (SEER), Dukes' system and Tumour-Node-Metastasis (TNM), but there are no universally agreed terms regarding different stages of CRC as reported in Table 2.10.

Table 2.10 CRC staging information submitted/used in CRCS

	Providers [8]	HIRA [50]	NHI [8]	KCCR [15]	KAMS [92]
SEER 1,2,7,9	✓			✓	
TNM					✓
Stages		✓			
No stage information	✓		✓		

CRC colorectal cancer; **CRCS** colorectal cancer screening; **HIRA** Health Insurance Review & Assessment; **KAMS** Korean Academy of Medical Science; **KCCR** Korean Central Cancer Registry; **NHI** National Health Insurance; **SEER** Surveillance, Epidemiology and End Results; **TNM** Tumour-Node-Metastasis

Therefore, in this short-term analysis of the CRC cohort, CRC stages were estimated based on the comparison of SEER, Dukes' system and TNM (see Table 2.11) [91-93].

Table 2.11 Comparison of CRC stage using different classification system [91-93]

CRC stage	T	N	M	SEER code		Dukes	Estimated CRC stages, CRC cohort
0	Tis	N0	M0	LOC	0	-	DA
I	T1	N0	M0	LOC	1	A	DA
I	T2	N0	M0	LOC	1	A	DA
IIA	T3	N0	M0	REG	2	B	DB
IIB	T4a	N0	M0	REG	2	B	DB
IIC	T4b	N0	M0	REG	2	B	DB
IIIA	T1-2	N1/N1c	M0	REG	3	C	DC
	T1	N2a	M0	DIS	3	C	DC
IIIB	T3-4a	N1/N1c	M0	REG	4/5	C	DC
	T2-T3	N2a	M0	REG	5	C	DC
	T1-T2	N2b	M0	REG	5	C	DC
IIIC	T4a	N2a	M0	REG	5	C	DC
	T3-T4a	N2b	M0	DIS	7	C	DC
	T4b	N1-N2	M0	DIS	7	C	DC
IVA	Any T	Any N	M1a	DIS	7	-	DD
IVB	Any T	Any N	M1b	DIS	7	-	DD

CRC colorectal cancer; **DA** Dukes A; **DB** Dukes' B; **DC** Dukes' C; **DD** stage D CRC; **DIS** distant cancer; **DIS** distant cancer; **LOC** localised cancer; **M** distant metastasis; **M0** no distant metastasis; **M1** distant metastasis; **M1a** metastasis confined to one organ or site (for example, liver, lung, ovary, nonregional node); **M1b** metastases in more than one organ/site or the peritoneum; **T** primary tumour; **N** regional lymph nodes; **N0** no regional lymph node metastasis; **N1** metastasis in 1-3 regional lymph nodes; **N1a** Metastasis in one regional lymph node; **N1b** metastasis in 2–3 regional lymph nodes; **N1c** tumour deposit(s) in the subserosa, mesentery, or nonperitonealized pericolic or perirectal tissues without regional nodal metastasis; **N2** metastasis in 4 or more regional lymph nodes; **N2a** metastasis in 4–6 regional lymph nodes; **N2b** metastasis in 7 or more regional lymph nodes; **NCC** National Cancer Centre; **REG** regional cancer; **SEER** Surveillance, Epidemiology, and End Results; **Tis** carcinoma in situ; **T1** tumour invades submucosa; **T2** tumour invades muscularis propria; **T3** tumour invades through the muscularis propria into the pericorectal tissues; **T4** tumour penetrates to the surface of the visceral peritoneum or directly invades or is adherent to other organs or structures
SEER code 0 In situ; **1** Localized only; **2** Regional by direct extension only; **3** Regional lymph nodes involved only; **4** Regional by BOTH direct extension AND lymph node involvement; **5** Regional, NOS (Not Otherwise Specified); **7** Distant site(s)/node(s) involved; **9** Unknown if extension or metastasis (unstaged, unknown, or unspecified); Death certification only case

There are limitations in this analysis; the use of NHI reimbursement data lacks the continuity of collection in the case of changes in the report form and possible reporting errors. CRCS policy changed from biennial (2009-2011) to annual (2012), the results of this short-term analysis should be interpreted with caution.

Colorectal adenomas is a type of polyp, abnormal tissue growth in the rectum or the colon, which can be either pre-cancerous or benign [33]. Polyps can be categorised by the major histological groups of hyperplastic/metastatic polyp, neoplastic polyp and adenomatous polyp (adenoma). Adenomas can be classified by number, size (diameter), histologic type (tubular, villous or tubulovillous), dysplasia and location [94]. The number and size of adenomas are said to be positively correlated with the increase risk of advanced neoplasia [33, 39].

In the current reporting of CRCS results, adenomas are categorised by size, type (pathology test results) and the number present [40]. Based on the findings from an index COL, people with 3 or more adenomas, any adenoma > 10 mm, any tubulovillous or villous adenoma(s), any adenoma(s) with high-grade dysplasia or any serrated polyp(s) larger than 10 mm, are considered to be at a high risk of developing subsequent advanced adenomas and/or CRC, therefore COL surveillance is recommended 3 years after polypectomy in the first COL surveillance guideline in Korea [40, 67]. Despite the reported changes in the adenoma location related to age [95] the proportion of individuals who only had adenomas in the proximal colon remained unchanged significantly by age [96]. COL is a recommended follow-up test modality which enables the visualisation of the bowels, therefore, the specific location of adenomas was not considered important in the risk stratification of adenomas for this thesis.

The reporting of COL results did not include the number of adenomas detected/removed during the follow-up COL in the CRCS, therefore the number of biopsies taken during the follow-up COL was used as a proxy for the number of adenomas in the risk stratification for the economic model. The approximation of risk status of the COL subgroup highlighted the discrepancies in the risk stratifications in the current clinical guidelines and the reported CRCS results. The production of high quality data requires data collection procedures that are standardised over time with dedicated training of data collectors and appropriate tools for data collection leading to the future studies utilising comprehensive CRCS data to inform decision making in the NHI [88].

For the purpose of mapping common pathways in the CRCS it was necessary to define mutually exclusive pathways. Individuals must be in only one pathway group each year for the compliance and reported test results. The mapped pathways did not consider additional tests performed after CRC diagnosis or those individuals who dropped out of the CRCS but later returned to CRCS via separate pathways. Therefore, estimated resources used in the CRCS and CRC might have been under-estimated in this analysis. Furthermore, additional resources used and costs associated with the NC group were outside the current CRCS and NHI, thus lead to a possible under-estimation of resources used in the NC pathway. Insufficient evidence around the costs and benefits of CRCS has long been acknowledged.

Findings from the CRC cohort suggest that further diagnostic tests are performed after a positive FOBT or a positive COL result in the CRC combined with HCSU pathway. There is no mechanism to capture the duplication of diagnostic tests in the current reporting system in CRCS, leading to a potential under-estimation of

the diagnostic costs, thus the results should be interpreted with caution. There is no record of opportunistic screening activities; therefore, the potential pathway of 'cross-over' between CRCS in NHI and opportunistic screening was not included in this analysis.

This short-term analysis of CRCS highlights potential advantages of utilising NHI reimbursement data in population health research and confirms that it is a feasible alternative to clinical trials in the evaluation of costs and benefits of existing programmes in NHI. NHI data capture information about each episode of care across health services and enable the estimation of the cost of interventions on the population and for sub-groups. This analysis of CRCS not only provides information relevant for the economic evaluation of CRCS and follow-up COL but also demonstrates how the current clinical practice of other NCSPs can be mapped out in order to inform the decision making process. Further studies related to the role of the NHI reimbursement data in population health research and risk-based COL subgroup over a longer term in the CRCS, NHI are warranted.

2.2.6 Conclusion

Results from the CRC cohort analysis revealed varying pathways outside current CRCS policy including CRCS combined with HCSU, HCSU and NC. Reported resources used in the CRCS COL surveillance provide invaluable information for the future economic evaluation of CRCS in the NHI. Despite the short-term analysis (2009-2012) and the changes in CRCS policies from biennial to annual 2011, results from the subgroup analysis indicated that individuals would develop

CRC over the 15 year post-polypectomy. Therefore, a risk-based COL surveillance that is seamlessly linked with CRCS is needed in order to minimise double-running costs of CRC diagnostics between CRCS and HCSU in the NHI. Furthermore, a CRC cohort with a longer-term follow-up will provide further evidence of the adenoma-carcinoma sequence and the movements between the CRC disease states, this will be crucial to improving the robustness of the results of future economic evaluations. Results from this short-term analysis of CRCS provide the basis for the cost-effectiveness analysis of the COL surveillance in the CRCS, NHI.

3 REVIEW OF ECONOMIC EVIDENCE IN THE PREVENTION AND EARLY DETECTION OF COLORECTAL CANCER

3.1 Preamble to Research Paper II

It is important to understand how other researchers have modelled CRCS in order to inform the economic evaluation of COL surveillance in the CRCS, NHI. Common modelling approaches used, modelled follow-up strategies, chosen interventions and comparators, the source of parameter inputs, the source of quality of life data for the health states of interest, health states and the details of down-stream effects of CRCS in the model were systematically reviewed. Also, reported limitations and uncertainties addressed in the literature were critically appraised [97, 98]. Please see the numerical summary of searches for the review.

Numerical summary of the searches for the review

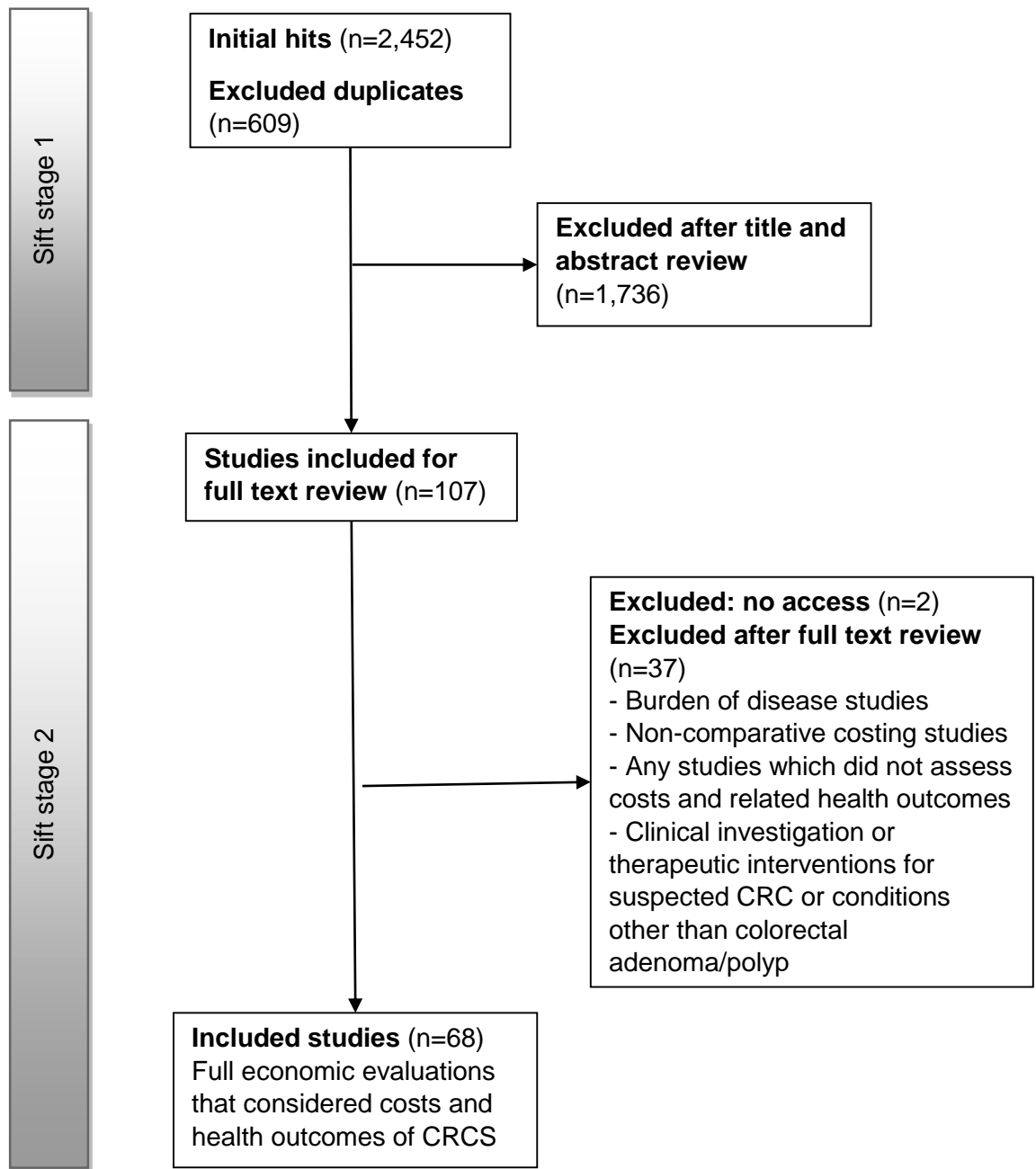

A review of the cost-effectiveness evidence carried out in a systematic manner for this thesis is presented in 3.2.

Since the publication of Research Paper II updates of the cost-effectiveness evidence were conducted (until 31 March 2015) as presented in 3.3. A report

relevant to this topic [99] was not captured in the original search because the report was indexed as a book in the database at the time of original search [100]. Therefore, the search was broadened to include the National Institute for Health and Care Excellence (NICE) website (www.nice.org.uk) to minimise the chance of missing relevant studies in the update.

Based on a published checklist [97] included studies were critically appraised. Of 68 studies reviewed from the original review [100] and 10 from search updates, approximately 227 different comparisons of the CRCS tests made were reported to be cost-effective compared to no CRCS. Mostly, stool-based CRCS strategies were cost effective compared to no CRCS or endoscopy-based screening strategies in an average risk group.

The evidence for the importance of colorectal polyps in the development of CRC was largely indirect, but nonetheless extensive and convincing and has been described in detail [101]. The structure of model was adequately reflecting the nature of the adenoma-carcinoma with the time horizon that was sufficiently long to reflect costs and health outcomes [76, 79, 96, 101, 102]. On the other hand, a shorter time horizon (10 years) was considered in estimating costs and outcomes of screening and/or surveillance strategies that was not sufficiently long enough to capture potential gains from the prevention of CRC [103, 104]. Estimated resource use was reasonable and up-to-date within 1-4 years except for one study [103]. For estimating costs and benefits of early detection and prevention of CRC through CRCS and COL surveillance, differentiated CRC disease states would be better suited than a single health state of CRC [105, 106], however more attention needs to be paid to report search methods in identifying model input parameters.

The review found consistent methodological flaws: 1) lack of clear descriptions of adenoma-carcinoma, justification of modelling approach [107-109]; 2) lack of clear description of perspective of analysis [105, 107-122]; 3) lack of description/justification of discounting of future costs and outcomes [107-109, 113, 123-125]; 4) the lack of exploration of uncertainty associated with important input parameters through sensitivity analysis [106-110, 112, 113, 120, 121, 123, 126-130].

Additional filters related COL surveillance strategies for people with confirmed adenomas and CUA were added in order to identify highly relevant studies for the CUA (Chapter 5). COL surveillance strategies were nested in a CRCS model structure [79, 96, 102]. Risk-based COL surveillance strategies were cost-effective in two previous studies [76, 99]. First, Saini (2010) [76] reported COL surveillance every 3 years in HR (> 2 adenomas or adenomas \geq 10 mm in size, villous or containing high-grade dysplasia) and every 10 years in LR (1-2 adenomas < 10 mm) were cost-effective. Second, NICE (2011) [99] reported COL surveillance every 3 years in HR (5 or more adenomas smaller than 10 mm or 3 or more adenomas if one is 10 mm or larger), every 3 years in intermittent risk (3 or 4 adenomas smaller than 10 mm or 1-2 adenomas if one is 10 mm or larger), and every 5 years in LR (one or two adenomas smaller than 10 mm) were cost-effective.

Utility loss from harm done by surveillance was not modelled except for Saini (2010) and NICE (2011) where disutility associated with COL was assumed to be 0.0025 [76, 99]. Therefore, a COL related disutility of 0.0025 was considered in the base-case of model.

Screening outcomes estimated by the model were validated against UK trial data [79]. Predicted outcomes from a natural history of adenoma-carcinoma (no COL

surveillance) in an average cohort were compared to observed data from 1975 SEER registry [76].

Findings from the review informed the modelling approach adopted in the economic evaluation of COL surveillance in the CRCS, NHI (Chapter 5).

Research Paper cover sheet - Research Paper II

London School of Hygiene & Tropical Medicine
Keppel Street, London WC1E 7HT
www.lshtm.ac.uk

Registration
T: +44 (0)20 7299 4846
F: +44 (0)20 7299 4856
E: registration@lshtm.ac.uk

LONDON
SCHOOL OF
HYGIENE
& TROPICAL
MEDICINE



RESEARCH PAPER COVER SHEET

PLEASE NOTE THAT A COVER SHEET MUST BE COMPLETED FOR EACH RESEARCH PAPER INCLUDED IN A THESIS

SECTION A- Student Details

Student	Kim Eyoung Jeong
Principal Supervisor	Professor John Cairns
Thesis Title	Cost-effective strategies in the follow-up of people with confirmed colorectal adenomas for the prevention and early detection of colorectal cancer in the National Health Insurance, South Korea

If the Research Paper has previously been published please complete Section B. if not please move to Section C

SECTION B – Paper already published

Where was the work published?	Health Economics Review		
When was the work published?	September 2013		
If the work was published prior to registration for your research degree, give a brief rationale for its inclusion	NA		
Have you retained the copyright for the work?*	Yes	Was the work subject to academic peer review?	Yes

If yes, please attach evidence of retention. If no, or if the work is being included in its published format, please attach evidence of permission from the copyright holder (publisher or other author) to include this work.

SECTION C – Prepared for publication, but not yet published

Where the work intended to be published?	
Please list the paper's authors in the intended authorship order:	
Stage of publication	Choose an item.

SECTION D – Multi-authored work

For multi-authored work, give full details of your role in the research included in the paper and in the preparation of the paper. (Attach a further sheet if necessary)	See next page.
--	----------------

Student Signature: _____ Date: _____
Supervisor Signature: _____ Date: _____

Title: Review of economic evidence in the prevention and early detection of colorectal cancer

Authors: Kim Jeong, John Cairns

Journal/Publisher: Health Economics Review/ SpringerOpen Journal

Type of publication: Literature Review

Reference: Jeong, K.E. and J.A. Cairns, *Review of economic evidence in the prevention and early detection of colorectal cancer*. Health Econ Rev, 2013. **3**(1): p. 20.

URL: <http://www.healtheconomicsreview.com/content/3/1/20>

DOI: [10.1186/2191-1991-3-20](https://doi.org/10.1186/2191-1991-3-20)

Copyright: Open Access, Permission not needed for inclusion in thesis

©Jeong and Cairns; licensee Springer. This is an Open Access article distributed under the terms of the Creative Commons Attribution License (<http://creativecommons.org/licenses/by/2.0>), which permits unrestricted use, distribution, and reproduction in any medium, provided the original work is properly cited.

Candidate's contribution: The candidate and John Cairns have been involved in all stages of the literature search, sifting and review of studies, revising the manuscript critically for important intellectual content. Data extraction and the writing the first draft of the manuscript were carried out by the candidate.

Competing interests: The candidate does not have financial or non-financial competing interests. Professor John Cairns received no financial sponsorship for this work and has no competing interests.

Acknowledgements: The candidate and John Cairns are grateful for advice from Paul Levay in developing search strategies.

3.2 Research Paper II Review of economic evidence in the prevention and early detection of colorectal cancer

3.2.1 Abstract

This paper aims to systematically review the cost-effectiveness evidence and to provide a critical appraisal of the methods used in the model-based economic evaluation of CRC screening and subsequent surveillance. A search strategy was developed to capture relevant evidence published in the period between January 1999 and November 2012. Databases searched were MEDLINE, EMBASE, National Health Service Economic Evaluation Database (NHS EED), EconLit and Health Technology Assessment (HTA). Full economic evaluations that considered costs and health outcomes of relevant interventions were included. Sixty-eight studies which used either cohort simulation or individual-level simulation were included. Follow-up strategies were mostly embedded in the screening model. Approximately 195 comparisons were made across different modalities, however, the strategies modelled were often simplified due to insufficient evidence and the chosen comparators in the model insufficiently reflected current practice or recommendations. Studies used up-to-date evidence on the diagnostic test performance combined with outdated information on CRC treatments. Quality of life relating to follow-up surveillance is rare. Quality of life relating to CRC disease states was largely taken from a single study. Some studies omitted to say how identified adenomas or CRC were managed. Besides deterministic sensitivity analysis, probabilistic sensitivity analysis (PSA) was

undertaken in some studies, but the distributions used for PSA were rarely reported or justified.

The cost-effectiveness of follow-up strategies among people with confirmed adenomas are warranted to aid evidence-informed decision making in response to the rapidly evolving technologies and rising expectations.

KEYWORDS

Colorectal cancer; Screening; Polyp; Adenoma; Cost-effectiveness; Cost-utility

3.2.2 Introduction

Colorectal polyps are small benign growths in the inner layer of the colon and rectum that can be either pre-cancerous or non-precancerous. Neoplastic colorectal polyps, known as adenomas, can be further divided into non-advanced and advanced dependent on the size, degree of villous features or grade of dysplasia [51, 131]. The number and size of adenomas are positively related to the risk of developing colorectal cancer (CRC) over 10 years or longer [37, 38, 131]. Evidence suggests that early detection and removal of colorectal adenomas (polypectomy) reduces the risk of developing CRC [37].

Several screening modalities are currently used in different sequences and with different intervals ranging from stool tests, barium enema (BE), colonoscopy (COL), sigmoidoscopy (SIG) to computerised tomography colonography (CTC). Each screening modality has particular benefits and potential harms. Despite the absence of sufficient evidence for or against specific CRC screening (CRCS) modalities, CRCS has been implemented in many countries [132-134]. Rapidly evolving technologies and increasing expectations from healthcare users tend to exceed financial affordability and health policy responses in many countries. Guidance is required regarding choice, order of modalities and appropriate intervals, in order to minimise potential harms and maximise benefits among the eligible population groups. This paper systematically reviews the cost-effectiveness evidence and provides a critical appraisal of methods used in the model-based economic evaluation of CRCS and subsequent surveillance.

3.2.3 Methods

A search strategy was developed (see Appendix Table A3.1). Databases searched were National Health Service Economic Evaluation Database (NHS EED), EconLit, MEDLINE, EMBASE and HTA and limited to studies published January 1999 to November 2012. An initial search using the search term 'surveillance' was extended to 'screening' because of the rarity of published cost-effectiveness analysis of follow-up strategies in the topic area, and also due to terminologies being used interchangeably in the published literature. Key terms used in the search were colonoscopy, surveillance, screening, adenoma and colorectal cancer. Economic filters were used when searching for economic evidence on generalist databases such as MEDLINE. Simplified searches without economic search filters were performed when searching the economics specific databases [135].

Full economic evaluations that considered costs and health outcomes of relevant types of intervention with outcomes expressed in cost per quality-adjusted life-year (QALY) or cost per life-year gained were included. Studies published pre-1999 [110, 136] were reviewed when they were used in the appraisal of newly introduced technologies. Sixty-eight studies were critically appraised by two reviewers using a set of criteria [137]. Search strategy (see Appendix Table A3.1), study selection criteria (see Appendix Table A3.2), included/excluded studies (Appendix Tables 3.3.1-3.3.2) are presented in Appendices and the included studies are summarised in Appendix Table A3.4.

3.2.4 Results

Findings from selected studies are discussed in the following section.

Economic models for surveillance programmes targeting people with a high risk of developing CRC were nested in the main screening model(s) in a number of studies. The countries of origin of the studies included in this paper are presented in Figure 3.1.

Figure 3.1 Included studies – counties of origin

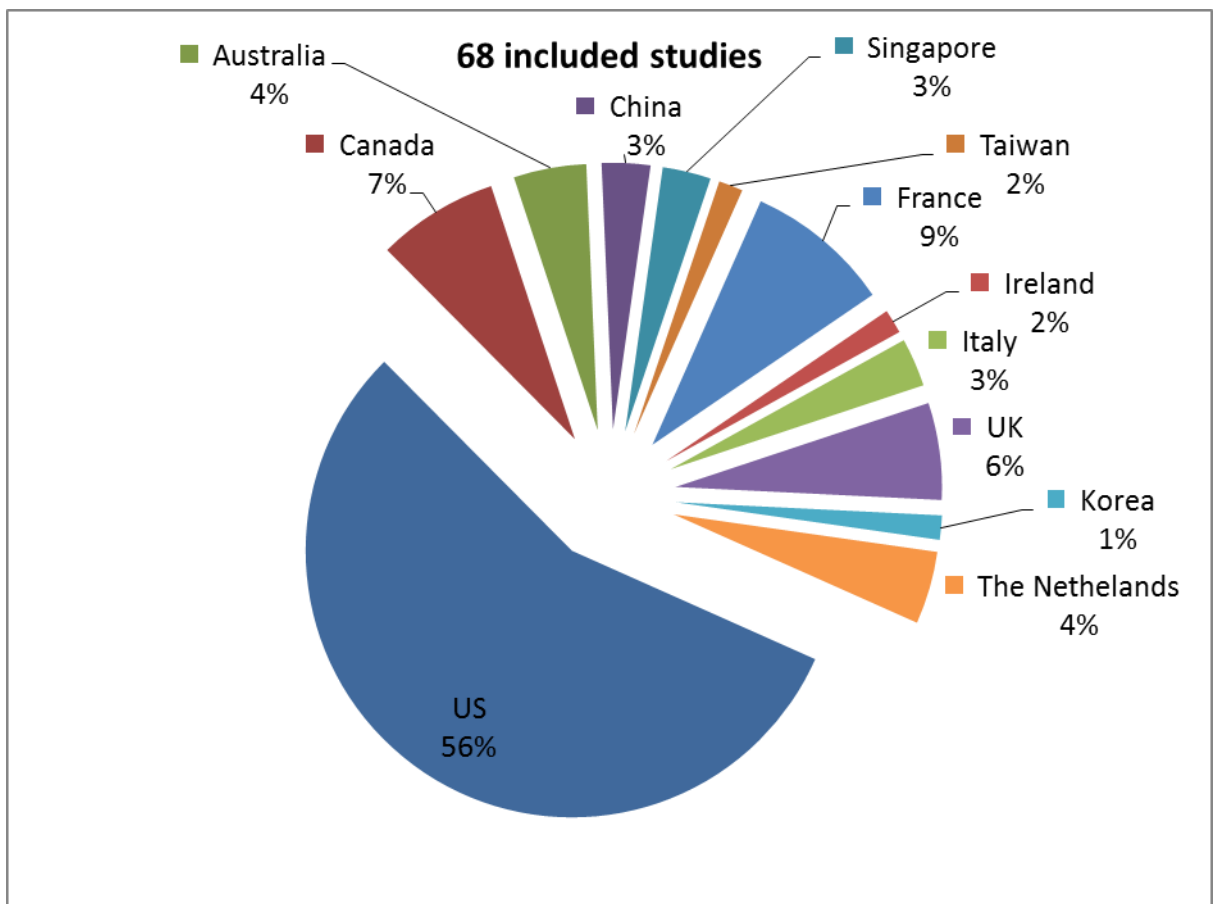

Modelling methods

Two modelling methods have been used: cohort simulation and individual-level simulation. Some studies provided a limited description of the model [106, 107, 130, 136, 138], others were marginal analyses of cost and benefits derived from published studies that were applied directly to the US population [112].

Computational complexity of the models ranged from a simple decision tree [82, 103, 113, 117, 125, 126, 139, 140] to a Markov model [102, 104, 105, 110, 111, 115, 116, 118, 119, 121, 124, 127-129, 141-159] to capture key aspects of the natural history of CRC. Most studies modelled the adenoma-carcinoma sequence over time. Threshold analysis was performed in some studies to investigate the optimal cut-off level for diagnostic tests or optimal reimbursement strategies for a new technology [160].

Individual-level simulation models [79, 101, 114, 120, 160-167] have been based on three micro simulation models: Micro Simulation Screening Analysis (MISCAN); Simulated Model of CRC; Colorectal Cancer Simulated Population model for Incidence and Natural History. These were independently developed within the National Cancer Institute-funded Cancer Intervention and Surveillance modelling Network (CISNET) consortium. The natural history of CRC in these models was calibrated to autopsy studies and to Surveillance, Epidemiology, and End Results (SEER) Program data for the pre-screening era (1975-1979) [161]. CISNET models subsequently led to a number of secondary analyses [101, 115, 120, 166, 167].

Initiation of CRC screening and subsequent follow-up was mostly around 50 to 60 years of age, while the timing of cessation of screening or surveillance varied. In some surveillance models, people remained in the surveillance programme

until the end of the simulation [161, 166]. As a result, the surveillance costs would have been overestimated.

Population considered

People at average risk were the main focus in most studies, with follow-up surveillance nested in the screening model. For people with positive FOBT results, COL was commonly used as a confirmatory test [82, 96, 104, 167]. The importance of follow-up surveillance of individuals at high risk of developing CRC has been recognised in recent years. For example, people with newly diagnosed adenomas were considered in a follow-up strategy using COL compared with no follow-up [155], and people with asymptomatic polyps were followed-up using CTC compared with immediate referral for COL with polypectomy [103, 117].

Screening modalities considered

The main interventions chosen for modelling were stool tests, COL, SIG progressed to CTC either alone or combined with another modality. CTC was often compared with existing technologies that have emerged in the recent years. Evidence and recommendations on the use of BE remain inconsistent thus BE was considered as one of the current modalities in some studies [121, 126, 143, 156] but excluded in others [118, 119].

Stool-based tests, including guaiac FOBT (gFOBT), immunochemical FOBT (iFOBT) and stool DNA tests were used for mass screening of those at average risk of developing CRC compared with no screening [108, 152, 156, 168]. COL was the common test for the follow-up of detected adenomas/polyps and positive test results from the initial screening tests. Unlike COL, SIG provides visualised

examination of the left side of the bowel depending on the length of endoscopy and the depth of insertion with no sedation [169]. Narrow-band imaging (NBI) is one of the latest technologies with *in-vivo* histology function compared with conventional white light COL, in which removed adenomas from COL (polypectomy) would be analysed in the lab [144].

Approximately 195 comparisons have been made across the 68 studies (simplifying considerations of the sequence of tests and excluding the interval of screening and follow-up strategies) as presented in Figure 3.2. This can be partly explained by differences in clinical practice between countries/settings dependent on the structure of health service delivery and reimbursement rules, as well as resource availability. Effectiveness and cost-effectiveness evidence relating to the combination of different tests or their sequence in CRC screening and follow-up was sparse. Stool-based tests were aggregated for simplicity. Each modality is coded using a different colour and shape outline. Numbers shared between circles or within a circle represent the number of comparisons across the studies. For example, NBI was compared with COL once; two comparisons were made of CTC followed by COL and CTC alone.

Figure 3.2 At a glance – 195 comparisons

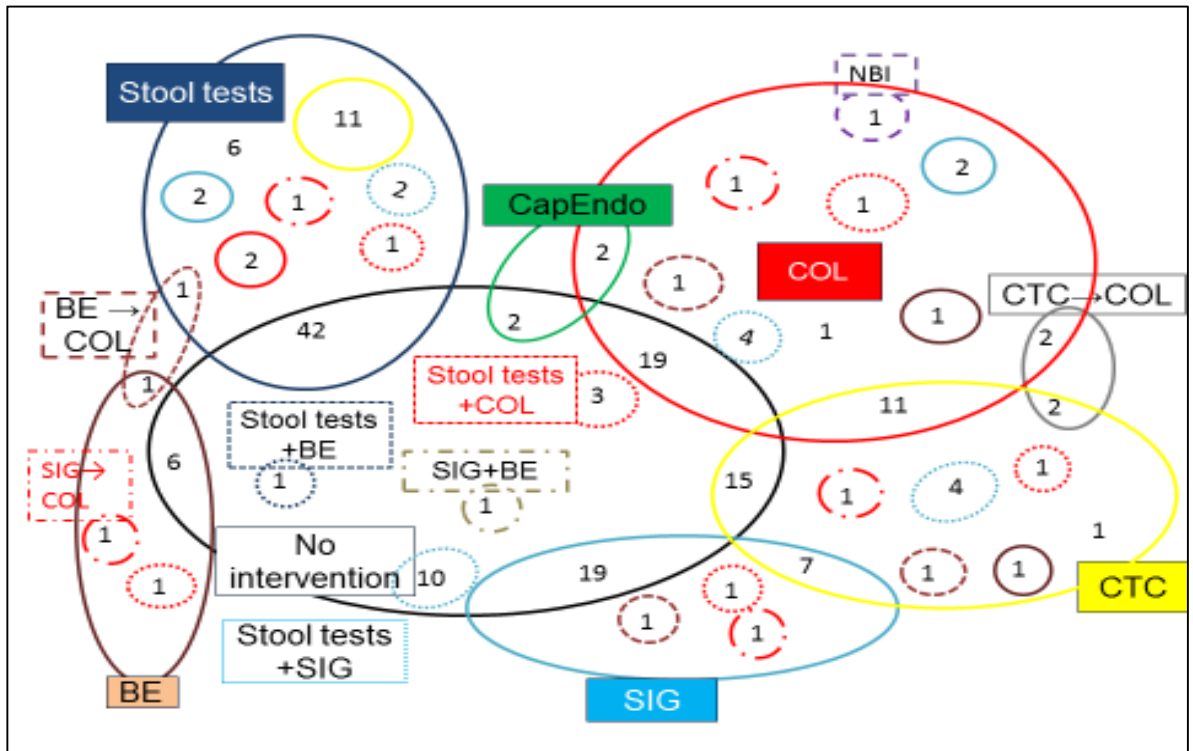

- Barium enema (BE) (brown solid)
- Barium enema and colonoscopy (BE→COL) (brown dotted)
- Capsule endoscopy (CapEndo) (green solid)
- Computerised-tomography colonography (CTC) (yellow solid)
- Computerised-tomography colonography followed by colonoscopy (CTC→COL) (grey solid)
- Colonoscopy (COL) (red solid),
- Narrow-band imaging (NBI) (purple dotted)
- No intervention (black solid)
- Sigmoidoscopy (SIG) (turquoise solid)
- SIG then COL (SIG→COL) (red dotted)
- Sigmoidoscopy combined with barium enema (SIG + BE) (olive green dashed)
- Stool tests (blue solid)
- Stool tests combined with BE (stool tests+BE) (brown solid)
- Stool tests combined with COL (stool tests+COL) (red dotted)
- Stool tests combined with SIG (stool tests+SIG) (turquoise)
- '+' combination of tests
- '→' sequence of test

Threshold analyses at various costs and sensitivity of CTC in detecting polyps were presented in comparison with existing modalities among an average risk population [101, 114, 166]. Some studies found CTC, with or without a threshold strategy for the size of polyps, would be cost-effective, while others found COL or iFOBT to be cost-effective. This depended on where CTC was used in the screening pathway either primary screening or secondary follow-up test. Cost-effectiveness of CTC was examined in recent years with an improved understanding of the test performance and indications among people with asymptomatic polyps or with a positive result from FOBT [103, 117, 170]. A definitive follow-up interval using CTC has not been empirically established, thus modelled intervals of CTC strategy varied from every 5 years to 10 years among the average risk population, or every 3 years among asymptomatic people with small polyps (6-9 mm) [128, 142, 151, 158].

The potential harm of CTC was rarely considered, although exposure to radiation from CTC every 3 or 5 years was reported to be low [128]. CTC was considered as a primary screening test in an average population compared to FOBT [141], COL [128] and SIG [101, 149, 161]. No studies have considered the costs and consequences of extra colonic findings from CTC.

CTC was not cost-effective as a follow-up test for individuals with positive results from stool tests when compared to COL [125, 158]. CTC was relatively cost-effective or cost-saving among people with polyps 6-9 mm as presented in Table 3.1 [103, 117]. The frequency and interval of the modelled strategies were restricted and simplified compared with day-to-day clinical practice and current guidance/recommendations. This could misrepresent the cost-effectiveness of CTC and other screening modalities [97].

Table 3.1. CTC as a follow-up test

	Population	Interventions	Sensitivity (Se, %) Specificity (Sp, %) [ranges]	Participation [Ranges for sensitivity analysis]	Reported outcomes
Pickhardt (2007) [105]	People with small polyps (6-9 mm) detected at CTC screening	CTC with or without polyp size reporting threshold (6mm) vs COL + polypectomy FSIG No screening	(<=5mm polyps, 6-9mm, >=10mm, CRC) CTC Se (48%, 70%, 85%, 95%) Sp 86% COL Se (80%, 85%, 90%, 95%) Sp 90% FSIG (45%, 45%, 60-65%, 90%)	Initial 65% [1-100] Repeated 80% [1-100]	Compared with No screening (currency USD); \$4361 per LYG (CTC with a 6-mm threshold), \$7138 per LYG (CTC with no threshold), \$7407 per LYG (FSIG), \$9180 per LYG (COL). Compared with COL, CTC with a 6-mm threshold resulted in a 77.6% reduction in invasive endoscopic procedures and 1112 fewer reported COL-related complications from perforation or bleeding. CTC with non-reporting of diminutive lesions was found to be the most cost-effective and safest screening option evaluated.
Pickhardt (2008a) [103]	60 years old asymptomatic polyps; diminutive (<=5mm), small (6-9mm), large (>=10mm)	CTC then COL with polypectomy vs CTC only	polyps (<=5mm, >=6mm, >=10mm,) CTC Se (48%, 89%, 94%) CTC Sp (80%, 8%, 96%)	100% (assumption)	(Currency USD) Estimated 10Y CRC risk for unresected diminutive (0.08%), small (0.7%) and large polyps (15.7%). ICER of removing all diminutive polyps was \$465,407 perLYG, and small CTC-detected polyps \$59,015 per LYG. Polypectomy for large CTC-detected polyps yielded a cost-saving of \$151 per person screened.

	Population	Interventions	Sensitivity (Se, %) Specificity (Sp, %) [ranges]	Participation [Ranges for sensitivity analysis]	Reported outcomes
Pickhardt (2008b) [117]	60 years old asymptomatic individuals with small polyps (6- to 9-mm) detected at CTC screening	3-yearly CTC surveillance vs Immediate polypectomy	CTC Se (polyps 6-9mm) 89%, Sp 80% COL Se (6-9mm polyps) 85%, Sp 100%	Not stated	(Currency USD) Without any intervention, the estimated 5-year CRC death rate from 6- to 9-mm polyps in this concentrated cohort was 0.08%, which is a sevenfold decrease over the 0.56% CRC risk for the general unselected screening population. The death rate was further reduced to 0.03% with the CTC surveillance strategy and to 0.02% with immediate colonoscopy referral. However, for each additional cancer-related death prevented with immediate polypectomy versus CTC follow-up, 9,977 COL referrals would be needed, resulting in 10 additional perforations and an incremental cost effectiveness ratio of \$372,853.
Walleser (2007) [125]	Individuals with a positive FOBT	CTC vs COL	(CRC-polyps ≥ 10 mm - polyps 6-9mm) CTC Se (89 [70-98]-63 [59-85] - 51 [41-60]) Sp CTC lesions ≥ 6 mm 90 [88-92] COL Se (96[80-100]-95 [90-98]-99[95-100]) Sp COL lesions ≥ 6 mm 99.6 [99.2-100]	Not stated	Australian dollars per life-years gained CTC is less effective and more costly than COL; if CTC was more sensitive than COL, CTC was more effective, at higher cost.

COL colonoscopy; **CRC** colorectal cancer; **CTC** computerised tomography colonography; **FOBT** fecal occult blood test; **FSIG** flexible sigmoidoscopy; **ICER** incremental cost effectiveness ratio; **LY(G)** Life Years (Gained); **USD** United States dollar

Management of polyps/adenomas and CRC

Follow-up was modelled for those with positive results from stool-based tests or polyps detected using endoscopy-based tests or image-based tests. For confirmed polyps, the interval and the degree of complexity of follow-up strategies varied greatly from simple COL at 3 -10 years after initial polypectomy to multiple strategies based on the current recommended guidelines [136, 159, 171]. Follow-up was nested within a Markov model [126, 147, 152, 153] or a discrete event simulation [79, 172], or not modelled [151]. Crudely simplified follow-up strategies were considered with assumptions that departed from the real-world, for example, 100% compliance or a common compliance rate at any screening round [103, 136, 160, 162, 163]. Cost-effectiveness was generally recognised to depend on compliance with screening, however, one study suggested that high compliance rates were not necessary to achieve cost-effectiveness [113].

Detected polyps were grouped into a single state or two or three depending on number and size of polyps found at the baseline COL [79, 105, 123, 145]. Modelled disease states of CRC were mainly local, regional or distant (disseminated, CRC or Dukes' stages A to D). In some studies a single CRC disease state was used with an average lifetime treatment cost predicted or estimated, thus the results failed to predict benefits of early detection and prevention of CRC [106, 113, 129]. More recently the costs of CRC stage-specific treatment were modelled including combination and/or sequence of treatments [96, 119, 142, 171]. Costs of CRC treatment were not stated, or were crudely simplified as lifetime costs [129], or directly lifted from previous publications without adjusting to the current year [105, 139]. Given that the primary goal of screening is prevention and early detection of disease, it is crucial to capture not

only the initial years of screening [168] but also the longer term benefits accrued over a lifetime. Any differences in the CRC treatment costs as a result of prevention or early detection of CRC were not distinguished in the model.

Input parameters

Since direct evidence on the natural history of CRC is lacking, input parameters were taken from multiple sources ranging from epidemiological studies, hospital records, disease registries and expert opinion.

Papers emphasised the improved test performance of their chosen modalities (and their effectiveness and cost-effectiveness) but often combined more recent information on test performance with existing, outdated information on resource use. For example, the cost-effectiveness of CRC screening with CTC was presented using a single CRC treatment cost taken from a previous study [173] and costs per test from 1998 [105]. COL related complications were modelled in terms of costs. Test performance of CTC varied in the studies from 33% to 100% depending on the size of polyp (see Table 3.1) [103, 105, 117]. In the absence of sensitivity and specificity data for new technologies, test performance similar to existing tests was assumed [128]. Quality of life relating to CRC was repeatedly taken from a single study [174] for over a decade [79, 102, 142, 171]. More recently, EQ-5D values of cancer-free and cancer states have been estimated from a national survey [96].

Handling uncertainties and model validation

Key assumptions were mainly examined using deterministic sensitivity analyses of the adenoma-carcinoma sequence, CRC prevalence rate, test performance, and compliance rate. In addition, threshold analyses, and scenario analyses were performed to address different types of uncertainty [101, 114, 166]. However, test performance of screening modalities was not subject to sensitivity analysis in some studies [143, 175]. Sensitivity analyses in most cases confirmed the base-case finding. Besides uncertainty from sampling variation in the general population, synthesising evidence from multiple sources in order to estimate cost-effectiveness adds another layer of uncertainty. PSA was performed considering the uncertainty surrounding all parameters simultaneously [76, 79, 138, 148, 158] complementing the deterministic sensitivity analyses. The distributions used for PSA were reported in only two studies, although no justification was given for choosing these distributions [102, 141]. Uncertainties surrounding input parameters were addressed using appropriate types of sensitivity analyses in some studies, thus improving credibility and robustness of the reported results. For example, a number of scenario analyses were considered in which different adherence rates and lower subsequent adherence rates were applied across strategies [171]. Results were sensitive to costs but sometimes the cost data were not considered in the sensitivity analyses [105]. Other studies did not address the limitations related to their assumptions [106, 107, 121]. Methods for economic evaluation have been consolidated further over time and authors have accordingly explored uncertainty to a greater extent in recent publications.

Validation of models is desirable in order to minimise errors and improve study credibility and consistency with methodological guides [176]. Model results were not validated in early publications because no data set was available [110, 162, 163]. An extensive ‘debudding exercise’ and the review of model structure by independent clinicians were reported as internal validation [171]. Validation of models was performed by comparing model simulation results with actual data sets [76, 105, 111, 116, 139, 154, 157, 175] or by calibration against published studies [114, 147, 153].

Validation results showed overestimated efficacy for polypectomy [144], underestimated prevalence of adenoma compared to an existing study [151], or significantly different CRC incidence compared to a recent publication [117], slightly underestimated CRC mortality compared to existing studies [102] or the model’s prediction of CRC incidence reduction was consistent with the available data [118].

3.2.5 Discussion

Evidence on the natural history of CRC is limited. The studies identified were predominantly model-based economic evaluations because no single trial could provide the large sample and long-term follow-up data required to compare screening strategies with differing screening intervals and sequences/combinations of tests. The assumed constant risks of individuals developing CRC would have under- or over-estimated CRC incidence and subsequent resource use for its treatment.

In clinical practice, a sequence of the same or different tests is performed in CRC screening. Compared to current practice, the modalities modelled were limited

and the adenoma-carcinoma sequence was crudely simplified. As a consequence of rapidly evolving technology and the quite poor evidence base regarding natural history, costs and health outcomes, many evaluations have been of limited value in informing routine clinical practice.

It is vital to know which test(s) should be considered first in a given population or in what combination or sequence, in order to maximise health benefit considering best available effectiveness and cost-effectiveness evidence in the prevention and early detection of CRC. For example, CTC appeared to be cost-ineffective as a primary screening modality compared with other tests among the average risk population, but potentially could be cost-effective when used as a follow-up test in a selected population in a pathway. A pathway for CRC including screening, follow-up surveillance and treatment for CRC would provide a bigger picture compared with studies that provide a snapshot view [177]. Given the computational complexity and additional data required for a pathway model, a balance must be struck between transparency and flexibility when choosing the modelling approach in each context.

The studies often omitted to say (or simplified) how identified adenomas or CRC were to be managed or treated. CRC screening and follow-up tests aim to detect early CRC or prevent CRC, thus the consequent costs and health benefits should be accounted for in the model. The improved test performance of newer modalities was captured, but their downstream effects for screening/follow-up were dated. Current or existing guidance on the cost-effectiveness analysis of CRC treatments should be linked to the diagnostic tests when estimating cost-effectiveness of CRC screening and follow-up strategies. This is because the cost-effectiveness of a diagnostic strategy depends in part on the consequences for subsequent treatment. Furthermore, for the cost-effectiveness of a new

treatment, evidence tends to be generated through randomised clinical trials. However, input parameters for quality of life have suffered from selection bias because searches for data have not been conducted systematically and values generally have come from observational studies. Efforts should be made to have up-to-date input parameters for down-stream effects in order to estimate the cost-effectiveness of new modalities with less bias and uncertainty.

Test performance and compliance rates will vary between screening rounds and subsequent follow-up testing. Such variations were crudely simplified by assuming a fixed test performance and a constant compliance rate, and were explored using deterministic sensitivity analysis in most studies. Further studies varying test performance and compliance rates at each screening round dependent on different tests are recommended.

Extra colonic findings from CTC will influence average screening costs and the subsequent health outcomes, and therefore should be considered in order to estimate the relevant costs and health outcomes of CTC strategies.

The time period during which the cancer is asymptomatic but detectable by the screening test or the time by which the CRC was diagnosed through screening were insufficiently modelled and explored in sensitivity analyses. Assumptions are necessary when constructing a model and uncertainties are introduced at various stages, for example, multiple sources of key parameters to populate the model (parameter uncertainty), and the choice of health states (structural uncertainty). Sensitivity analyses of carefully chosen aspects of uncertainties can increase confidence in or question results. Due to the limited evidence on the natural history of the adenoma-carcinoma sequence, key assumptions are required, however, the subsequent structural uncertainty was not fully explored in most studies. Alternative choices of health states or care pathways should be

explored using different scenario analyses. Parameter uncertainty was not fully explored, although uncertainties around mean health and mean cost were explored to a degree. Cost data were rarely explored in PSA and when they were, the distributions were poorly justified.

Cost-effectiveness of follow-up strategies and the inter-relation between CRC screening and follow-up programmes need further study. In addition, other factors, such as healthcare financing and delivery of health service, should also be considered because a modality can be cost-effective in a specific setting, however, this does not guarantee cost-effectiveness in a different setting.

CRC screening and follow-up tests can be invasive with unintended consequences, such as perforation and bleeding, and also involve pre-procedural preparation and post-procedure rest. These impacts on quality of life have been under-studied and under-reported in most studies. Quality of life data in relation to CRC and colorectal adenoma are very limited, and for over a decade were largely based on a single study [174]. It is imperative to establish a better understanding of the impact on quality of life of CRC screening and follow-up in people with adenomas and CRC.

3.2.6 Conclusion

Despite many cost-effectiveness analyses having been published, important aspects remain under-researched, including the consideration of downstream effects (such as management of adenoma and CRC) linked to appropriate screening or follow-up tests. It is important to assess the cost-effectiveness of different combinations or sequences of follow-up strategies for those with positive results and identified adenomas from mass screening. Information generated will

serve as a key link between a mass CRC screening programme and the most appropriate follow-up tests and relevant treatments, this will also aid decision makers to introduce appropriate guidance/policy and will promote clinically effective and cost-effective follow-up strategies to appropriate individuals. Therefore, cost-effectiveness analysis of follow-up tests for people with confirmed adenomas is warranted.

3.3 Updates of Research Paper II

A detailed assessment of the economic evidence related to COL surveillance was provided in the Research Paper II [100]. A new economic model may not be always required if there is existing economic evaluation that could be adopted for the relevant setting of interest. This review has identified important gaps in the existing evidence at the time of publication.

A search update of Medline and Embase was carried out on 31 October 2015 and NHS EED to 31 March 2015 (ceased March 2015). A report relevant to this topic [99] was not captured in the original search because the report was indexed as a book in the database at the time of original search [100]. Therefore, the search was broadened to include the National Institute for Health and Care Excellence (NICE) website (www.nice.org.uk) to minimise the chance of missing relevant studies in the update. Table 3.2 presents the search update.

Table 3.2 Search update

Initial hits	N=1,453
Duplicates removed	N=46
Included for full text review after screening title/abstract	N=143
Included for full-text review	N=52
Included after full-text review	N=18
Included for review	N=10

A total of 1,453 additional publications were identified from the search. After sifting through the studies according to the selection criteria, 10 studies were selected to be included in the review update (see Appendix Table A3.5) [178-187].

Main findings from the 10 included studies are:

1) In addition to the existing 195 comparisons, thirty-two comparisons were further identified from the review update and the published Figure 2 was updated accordingly (see Figure 3.3). Stool-based tests and COL remained the most commonly chosen intervention for comparison. On the other hand, the sequential tests of FOBT then CTC followed by COL is compared to the stool test combined with COL [179].

2) Polyp/adenoma management is increasingly considered part of the CRC screening model in some studies [179, 180, 182, 183, 185-188], however, no clear cost-effective strategies were reported in the follow-up COL surveillance among people with confirmed adenomas in CRCS.

These findings are consistent with those from published studies, therefore the key findings from the original review remains relevant.

Figure 3.3 Updated Figure 2 At a Glance – 227 comparisons

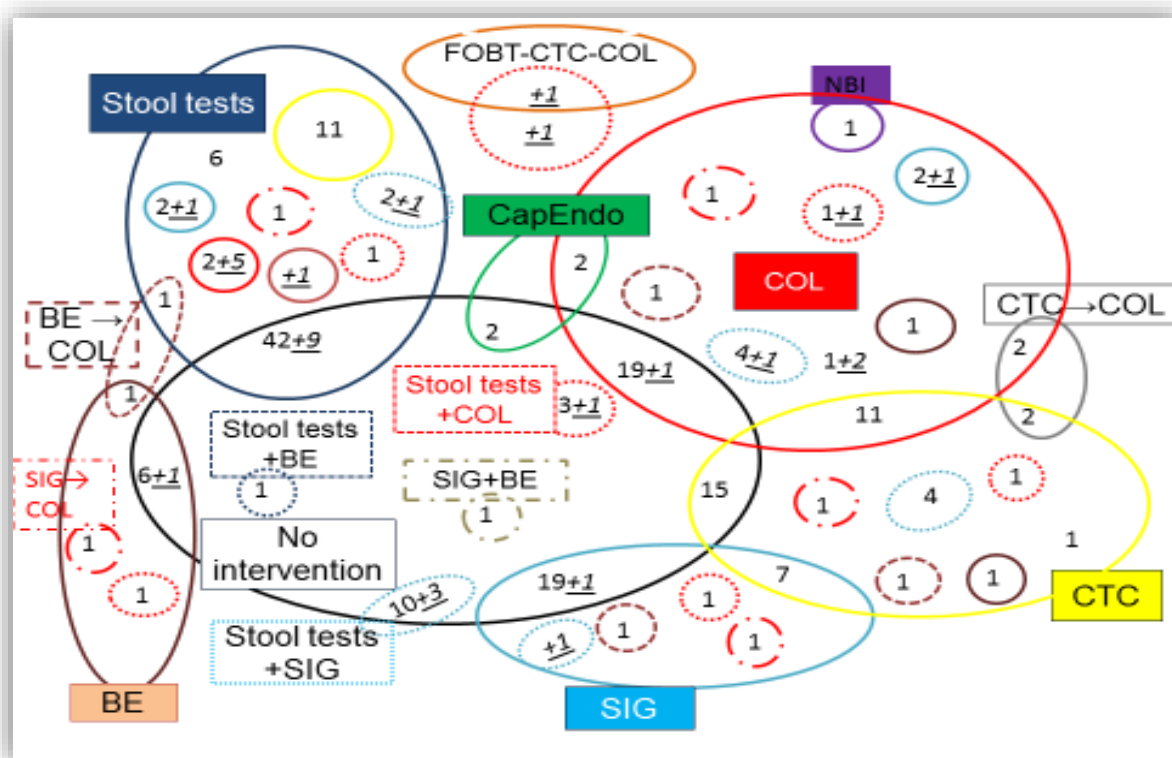

- Barium enema (BE) (brown solid)
- Barium enema and colonoscopy (BE→COL) (brown dotted)
- Capsule endoscopy (CapEndo) (green solid)
- Computerised-tomography colonography (CTC) (grey solid)
- Computerised-tomography colonography followed by colonoscopy (CTC→COL)
- Colonoscopy (COL) (red solid); Narrow-band imaging (NBI) (purple solid),
- No intervention (black solid); Sigmoidoscopy (SIG) (turquoise solid)
- Sigmoidoscopy combined with barium enema (SIG + BE) (olive green dashed)
- Stool tests (blue solid); Stool tests combined with BE (stool tests+BE) (brown solid)
- Stool tests combined with COL (stool tests+COL) (red dotted)
- Stool tests combined with SIG (stool tests+SIG) (turquoise dotted)
- Faecal occult blood test (FOBT) then CTC followed by COL (FOBT→CTC→COL) (Orange solid)
- '+' combination of tests; '→' sequence of test
- Added interventions from updated search (+underlined number in Italic)

4 SYTEMATIC REVIEW OF HEALTH STATE UTILITY VALUES FOR ECONOMIC EVALUATION OF COLORECTAL CANCER

4.1 Preamble to Research Paper III

This chapter provides a detailed assessment of HSUVs for economic evaluation of CRC. In the next Research Paper III, the systematic review of evidence on the HSUVs will be addressed in order to identify potentially relevant HSUVs that are methodologically robust with health states of interest, which could be used in the cost-effectiveness analysis of COL surveillance in the prevention and early detection of CRC. This review assesses the advantages and disadvantages with respect to valuation methods used and CRC clinical pathways. An approach taken in a published systematic review of HSUVs of breast cancer [189] was adopted in the quality appraisal of CRC HSUVs.

Of 57 studies included in the review, each study contributed between 1 and 16 HSUVs. There was a limited number of HSUVs that were methodologically robust with the range of health states of interest that can inform the planned CUA (Chapter 5). A total of 368 HSUVs were identified from this review; however, the states which the HSUVs refer to were predominantly metastatic CRC stages. Reported HSUVs were often complex making pooling of values problematic. A further search was undertaken to identify HSUVs for an economic model in a Korean context using Korean databases (Appendix 5.6.1). Many studies collected HRQoL of a sample from CRC patients, the metastatic CRC stage in

particular. In the absence of directly relevant HSUVs for CRC among Koreans in a Korean setting, a set of HSUVs [190] was chosen because it was methodologically robust with health states of interest for the economic model from a group of people with similar mean age to that of the CRC cohort. Cross-sectional data were collected among people with confirmed polyps or cancer (n=554; mean age \pm SD 63.3 \pm 11.3) using the Chinese SF-6D in Hong Kong. The health preference scores were calculated by converting health state into a single index weighted summation from the SF-6D preference weight coefficients, based on published scoring algorithm for the Hong Kong population. Authors acknowledged the limitations of the study including the possible sampling bias resulting from convenience sampling from a specialist clinic leading to a limited generalisability of findings, and a high proportion of unemployed, low household income, or low level of education in the sample. To facilitate a consistent approach to appraisals across different areas, some institutes or organisations define a set of criteria for the economic evaluation which specifies that HSUVs should be derived from standardised and validated generic instruments which use a choice based method either time trade-off (TTO) or standard gamble (SG), and takes preference from the general public [83, 191]. However, CUAs utilising Korean data was 3 out of 16 CUAs with no study related to CRC [10]. Therefore, despite acknowledged limited generalisabilities of HSUVs [190] it was considered most pertinent with relevant health states in order to inform the CUA (Chapter 5) compared to other HSUVs.

There are challenges in obtaining robust values for health states in COL surveillance. Findings may have limited generalisability if a sample size is not large enough. Unlike other pre-cancerous conditions, adenomas are asymptomatic. The impact on the utility values of asymptomatic adenomas or

future risk of CRC in people with asymptomatic adenomas remains uncertain. Additionally, it is unknown if the existing risk status related to adenomas would have an impact on the (dis)utility and whether the (dis)utility remains constant or diminishes over time. Future research related to the (dis)utility values concerning COL surveillance is warranted.

Further searches of databases after 31 October 2015 have not been conducted since the publication of Research Paper III. Findings from this systematic review informed the modelling of different health states associated with CRCS and CRC and HSUVs for the economic model (Chapter 5).

Research Paper Cover Sheet - Research Paper III

London School of Hygiene & Tropical Medicine
Keppel Street, London WC1E 7HT
www.lshtm.ac.uk

Registration
T: +44(0)20 7599 1846
F: +44(0)20 7599 1856
E: registration@lshtm.ac.uk



RESEARCH PAPER COVER SHEET

PLEASE NOTE THAT A COVER SHEET MUST BE COMPLETED FOR EACH RESEARCH PAPER INCLUDED IN A THESIS

SECTION A- Student Details

Student	Kim Eyoung Jeong
Principal Supervisor	Professor John Cairns
Thesis Title	Cost-effective strategies in the follow-up of people with confirmed colorectal adenomas for the prevention and early detection of colorectal cancer in the National Health Insurance, South Korea

If the Research Paper has previously been published please complete Section B. if not please move to Section C

SECTION B – Paper already published

Where was the work published?	Health Economics Review		
When was the work published?	August 2016		
If the work was published prior to registration for your research degree, give a brief rationale for its inclusion			
Have you retained the copyright for the work?*	Yes	Was the work subject to academic peer review?	Yes

If yes, please attach evidence of retention. If no, or if the work is being included in its published format, please attach evidence of permission from the copyright holder (publisher or other author) to include this work.

SECTION C – Prepared for publication, but not yet published

Where the work intended to be published?	
Please list the paper's authors in the intended authorship order:	
Stage of publication	Choose an item.

SECTION D – Multi-authored work

For multi-authored work, give full details of your role in the research included in the paper and in the preparation of the paper. (Attach a further sheet if necessary)	See next page.
--	----------------

Student Signature: _____ Date: _____

Supervisor Signature: _____ Date: _____

Title: Systematic review of health state utility values for the economic evaluation of colorectal cancer

Authors: Kim Jeong, John Cairns

Type of publication: Literature Review

Reference: Jeong and Cairns Health Economics review (2016) 6:36 Systematic review of health state utility values for economic evaluation of colorectal cancer

URL: <http://healtheconomicreview.springeropen.com/articles/10.1186/s13561-016-0115-5>

DOI: 10.1186/s13561-016-0115-5

Copyright: Open Access; Permission is not needed for inclusion in this thesis

© 2016 The Author(s). **Open Access** This article is distributed under the terms of the Creative Commons Attribution 4.0 International License (<http://creativecommons.org/licenses/by/4.0/>), which permits unrestricted use, distribution, and reproduction in any medium, provided you give appropriate credit to the original author(s) and the source, provide a link to the Creative Commons license, and indicate if changes were made.

Candidate's contribution: The candidate and John Cairns have been involved in all stages of the literature search, sifting and review of studies, revising the manuscript critically for important intellectual content. The candidate undertook data extraction and prepared the first draft of the manuscript.

Competing interests: The candidate does not have financial or non-financial competing interests. Professor John Cairns received no financial sponsorship for this work, and has no competing interests.

Acknowledgements: The candidate and John Cairns are grateful for advice from Paul Levay in developing search strategies.

4.2 Research Paper III Systematic review of HSUVs for economic evaluation of CRC

4.2.1 Abstract

Cost-utility analyses undertaken to inform decision making regarding colorectal cancer (CRC) require a set of health state utility values (HSUVs) so that the time CRC patients spend in different health states can be aggregated into quality-adjusted life-years (QALY). This study reviews CRC-related HSUVs that could be used in economic evaluation and assesses their advantages and disadvantages with respect to valuation methods used and CRC clinical pathways. Fifty-seven potentially relevant studies were identified which collectively report 321 CRC-related HSUVs. HSUVs (even for similar health states) vary markedly and this adds to the uncertainty regarding estimates of cost-effectiveness. There are relatively few methodologically robust HSUVs that can be directly used in economic evaluations concerned with CRC. There is considerable scope to develop new HSUVs which improve on those currently available either by expanded collections of generic measures or by making greater use of condition-specific data, for example, using mapping algorithms.

KEYWORDS

Health state utility value; colorectal cancer; quality-adjusted life year (QALY); economic evaluation

4.2.2 Introduction

Colorectal cancer (CRC) is the third most commonly diagnosed cancer worldwide [192]. CRC was traditionally more common in the western world but some Asian countries have shown an increase in CRC incidence in recent years [193]. Economic evaluation to inform decision making regarding CRC requires a set of health state utility values (HSUVs) so that the time CRC patients spend in different health states can be aggregated into quality-adjusted life-years (QALYs).

There are four ways by which the required HSUVs can be empirically generated:

(1) There are generic preference-based measures (PBM), such as the EQ-5D, SF-6D, 15D and the HUI3, where generic health states are valued using a tariff based on the preferences of the general public elicited using methods such as the time trade-off (TTO) and the standard gamble (SG).

(2) An alternative approach is to identify a number of relevant cancer-specific health states (as opposed to using generic health state descriptions) and to value these health states directly, again using methods such as the TTO and the SG. In this case the valuations are potentially made by cancer patients themselves, health care professionals or the general public.

(3) A variation on this second approach is to develop a preference-based algorithm with which a full range of cancer-specific health states can be valued. Two such measures, the EORTC-8D and the QLU-C10D, are based on items from the Quality of Life Questionnaire C30 (QLQ-C30).

(4) Finally, a mapping algorithm can be used to transform cancer-specific data such as the EORTC QLQ-C30 and the Functional Assessment of Cancer Therapy-General (FACT-G) into generic PBMs.

This paper reviews CRC-related HSUVs that could be used for economic evaluations and assesses their advantages and disadvantages with reference to the valuation methods used and CRC clinical pathways.

4.2.3 Methods

The literature was searched to identify CRC-related HSUVs for use in economic evaluation. MEDLINE, MEDLINE In-Process & Other Non-Indexed Citations, Embase (up to 30 October 2015) and Health Economic Evaluations Database (HEED, up to December 2014) were searched using the keywords colorectal cancer, health-related quality of life, QALY and economic evaluation. The search was restricted to studies in English. The search was broadened to include the National Institute for Health and Care Excellence (NICE) website (www.nice.org.uk) to minimise the chance of missing relevant studies. Economic filters were used when searching for evidence on generalist databases, such as MEDLINE. A simplified search was undertaken without using economic filters, for evidence on economics databases such as HEED. A further search was run on non-economic databases, including MEDLINE, to capture studies that are relevant to mapping. Search strategies were reported in Appendix Tables A4.1-A4.2. Relevant conference abstracts were tracked for full journal publications. All search results were downloaded into EndNote and duplicates were removed. Titles and abstracts were screened between two independent reviewers and full papers that did not meet the inclusion criteria were excluded. The study selection criteria are reported in Appendix Table A4.3. Studies were included if they contained CRC-related HSUVs which had not been previously reported, be they

generic PBMs or directly valued CRC-related health state descriptions, or mapping to generic PBMs based on direct statistical association mapping.

Full text was acquired for the remaining studies (including those which had insufficient details, such as no abstract). All included studies were read and any disagreements were resolved by discussion between the two reviewers. Of the 285 papers identified as potentially relevant, 228 were excluded because they did not report CRC-related HSUVs but presented psychometric validation studies without internal validation properties, the values were previously reported in other included studies, they involved unspecified or not clearly specified CRC-related health states, or a primary mapping function was not reported.

A total of 57 studies were included in the review (see Appendix Table A4.4). The numerical summary of the search and selection process for the review is reported in Figure 4.1.

Figure 4.1 Numerical summary of the searches for the review

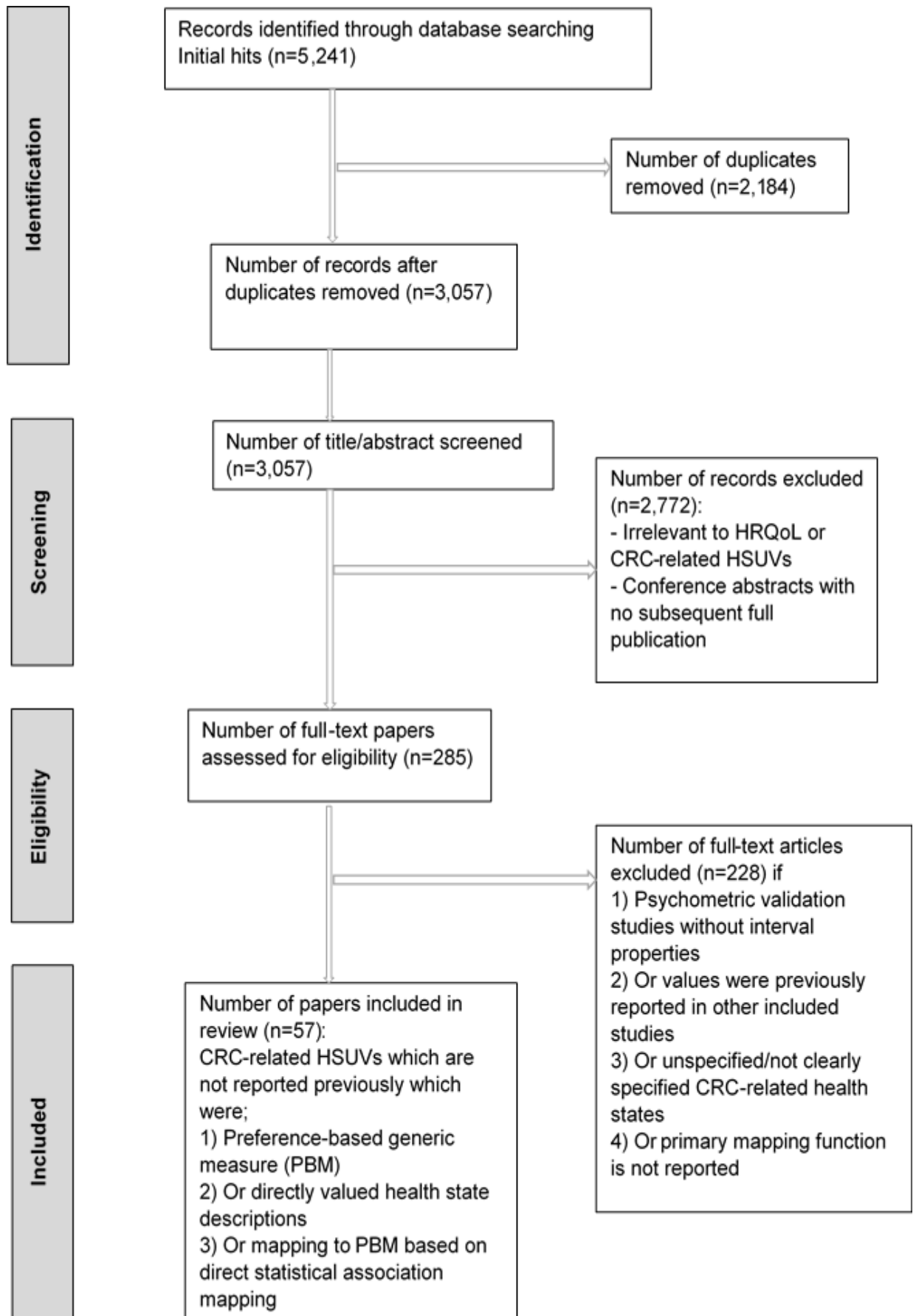

Descriptive characteristics (year of publication, country of origin, intervention type, number and mean age of respondents) and methodological characteristics (what was the measure of value; how the health state was described and valued; who valued it; how the QALY was aggregated) were collected for the fifty seven studies. Findings from selected studies are discussed in the following section.

4.2.4 Results

Of the 57 studies, eleven were set in the US [174, 194-203], eight in the UK [204-211], seven in the Netherlands [212-218], four in Canada [219-222], five in Hong Kong [190, 223-226], two each in Norway, Korea, Australia and Japan [227-234] and other country settings included Spain, India, Malaysia, Singapore, Sweden, and Turkey [235-242]. Some studies did not report their settings or were multinational or multicentre studies [243-248]. Studies were mostly published in the last 15-20 years and focussed narrowly on different interventions at specific stages of CRC. For example, the adverse events (AEs) of chemotherapy and survival (partial response) in metastatic CRC (mCRC) were the main conditions of interest in several studies [203, 209, 220, 221, 232, 236-238, 244, 246, 247]. HSUVs associated with rectal cancer have been reported [197, 207, 212-214, 216, 240, 242].

The 57 studies included in this review reported a total of 368 CRC-related HSUVs. All reported HSUVs are summarised in the Appendix Table A4.5.

Generic preference-based measures

Thirty-two studies collected health state information from CRC patients using generic PBMs and have applied health state tariffs based on the preferences of the general public. These studies generally collect data from patients recruited to trials, usually several hundred patients and at multiple time points. The most widely reported generic PBM is the EQ-5D valued using the UK (TTO-derived) value set with some exceptions [217, 245, 246] followed by the SF-6D [196, 222, 224, 225] and HUI3 [199, 200, 221].

Direct valuation of CRC health states

Fourteen studies directly valued CRC health states. Preferences have been elicited either using the TTO method with patients or a surrogate group [194, 195, 220, 232, 233, 236-238] or SG [174, 197, 202, 209, 219]. Generally, these studies involved fewer than 100 respondents. The participants were drawn from CRC patients, health care professionals and the community or general population (non-patient, non-health care professional). Only one study recruited a sample entirely from the general population [232] and one entirely from patients [174]. Mean utility values from health care professionals were lower than those from patients across health states [164, 201]. The remission health state was valued similarly by both groups, whereas the community group assigned lower values to adjuvant therapy-related AEs [194].

Preference-based condition-specific measures

Another approach has recently been developed which offers an alternative to using directly valued health states from the literature. The EORTC-8D is a cancer-specific PBM derived from the EORTC QLQ-C30 [249]. It utilises ten items from the thirty items of the QLQ-C30. A total of 85 EORTC-8D health states were valued by 350 members of the UK general public and these responses were then modelled to let any of the EORTC-8D states be valued. The QLU-C10D utilises twelve QLQ-C30 items to produce a ten dimensional measure, however, to date this approach has not been used to value CRC health states [250].

Mapping

The absence of data on generic PBMs from most cancer trials has generated considerable interest in mapping algorithms, from cancer-specific measures such as the Functional Assessment of Cancer Therapy-General (FACT-G) and the EORTC QLQ-C30 to measures such as the EQ-5D and the SF-6D [116, 251]. While several studies have reported mapping algorithms in the cancer area [190, 198, 222, 223, 229, 230, 235], only one of the mapping algorithms was developed using responses from CRC patients [252] and only one study reported HSUVs for different CRC-related health states based on an algorithm [226]. The mapping studies are summarised in Appendix Table A4.6.

HSUVs and the clinical pathway

For the purposes of estimating QALYs it is usually necessary to have information on HSUVs at several points along the clinical pathway. Evaluations of screening or diagnosis require valuations at the time of the intervention and subsequently following treatment.

CRCS-related HSUVs

Only one study reported CRC-screening related HSUVs as presented in Table 4.1 [215].

Table 4.1 CRC screening-related HSUVs

Valuation methods used	HSUVs reported	Reference
EQ-5D	Negative FS after positive FIT 0.81 Positive FS after positive FIT 0.82	Kapidzic (2012) [215]

COL colonoscopy; **CRCS** colorectal cancer screening; **FIT** faecal immunochemical test
FS flexible sigmoidoscopy; **HSUV** health state utility value

Colostomy-related HSUVs

Sixteen colostomy-related HSUVs were reported from 4 studies [174, 195, 201, 219]. Disutility of 0.09 [174] and of 0.111 [201, 219] were reported among rectal cancer patients with colostomy compared with those who without colostomy, respectively. The utility of having a stoma among former CRC patients with a reversed colostomy was 0.20 lower compared with those currently have a stoma [201]. HSUVs related to having a colostomy (surgery) and no colostomy (radiotherapy) were measured using SG in the primary treatment for rectal cancer. People with a colostomy assigned a higher value than people without a

colostomy [219]. The summary of colostomy-related HSUVs is presented in Table 4.2.

Table 4.2 Colostomy-related HSUVs

Valuation methods used	HSUVs reported	Reference
SG	With colostomy 0.915 Without colostomy 0.804	Boyd* (1990) [219]
TTO	[20 years with CRC; 20 years with a colostomy] Unscreened [0.80; 0.80] Screened [0.80; 0.75] Enrolled in a COL screening program [0.85; 0.79] CRC patients [0.83; 0.90]	Dominitz (1997) [195]
EQ-5D	With stoma 0.836 Without stoma 0.870	Hamashima (2002) [228]
SF-6D	With stoma 0.69 Without stoma 0.73	Hornbrook (2011) [196]
SG	Stage II/III rectal cancer, permanent colostomy 0.50 Stage II/III RC treated with resection, chemotherapy, radiation therapy and with permanent ostomy 0.50 Stage IV metastatic/ unresectable disease without colostomy 0.25 State IV metastatic/ unresectable disease with colostomy 0.25	Ness (1999) [174]
TTO	Currently with colostomy 0.84 Reversed colostomy 0.64 Community members 0.63	Smith (2006) [201]
EQ-5D	PRT and TME PS 0.823 TME PS 0.853	van den Brink (2004) [216]

* Reported HSUVs are re-expressed on a 0-1 scale; **COL** colonoscopy; **CRC** colorectal cancer; **HSUV(s)** health state utility values; **PRT** preoperative radiotherapy; **PS** permanent stoma; **RC** rectal cancer; **SG** standard gamble; **TME** total mesorectal excision; **TTO** time trade-off

HSUVs and colorectal polyps

Wong and colleagues [190] reported two HSUVs using SF-6D for those individuals with low- and high-risk colorectal polyps (0.871 and 0.832, respectively).

HSUVs and rectal cancer

HSUVs for hypothetical health states related to therapy for locally recurrent rectal cancer were higher among rectal cancer patients than health care professionals when measured using SG [197].

Two sets of rectal cancer-related HSUVs were reported at different time points and at different levels of surgery using EQ-5D and TTO values assigned by the UK general public [253, 254]. However, no standard deviation of mean values was reported. Overall, improved survival outweighed the disutility related to AEs of preoperative radiotherapy compared with surgery alone [207, 216]. A summary of rectal cancer-related HSUVs is presented in Table 4.3.

Table 4.3 Rectal cancer-related HSUVs

Valuation methods used	HSUVs reported	Reference
SG	[Healthcare professionals; patients] Disease recurrence [0.69; 0.72] Surgical resection[0.69; 0.83] Pain and complications [0.50; 0.78]	Miller (2000) [197]
EQ-5D	PRT+TME 0.70-0.86 Recurrent 0.67 (local) 0.70 (distant) 0.48 (local/ distant) TME 0.63-1.0 Recurrent 0.80 (local) 0.64 (distant) 0.45 (local/ distant)	Van den Brink (2004)**[216]
EQ-5D	Mean EQ-5D (SD) Baseline before TME 0.88 (0.15) 6 weeks after TME 0.85(0.18) 12 weeks after TME 0.87 (0.19) 26 weeks after TME 0.88 (0.17) 52 weeks after TME 0.86 (0.6)	Hompes (2015) [207]

** Ranges of reported HSUVs; **HSUV(s)** health state utility value(s)**PRT** preoperative radiotherapy; **SD** standard deviation; **SG** standard gamble; **TME** total mesorectal excision

HSUVs and AEs/ treatments of CRC

Best and colleagues (2010) [194] elicited preferences for seven health states associated with stage III colon cancer and adjuvant chemotherapy using TTO among CRC patients and community members. The TTO values for mCRC obtained from CRC patients were higher than those obtained from the community members. Several CRC health states were measured among CRC patients in Finland and were valued using the UK TTO tariff [239].

Skin toxicity is a common AE related to epidermal growth factor receptor (EGFR) agents. Improved HSUVs related to an EGFR agent were demonstrated using HUI3 among mCRC patients when compared with best supportive care. Health-related quality of life (HRQoL) was measured in mCRC patients and valued by the public [221]. Skin toxicity associated with mCRC treatments was reported to have little impact on HRQoL among mCRC patients [244, 246]. HSUVs obtained from patients with or without anti-EGFR treatment were applied to the duration of the AEs (days with grade 3 or higher AEs) and time without symptoms or toxicity (TWiST), and the differences were measured using a quality-adjusted time without symptoms of disease or toxicity of treatment (Q-TWiST) analysis [248]. Q-TWiST analysis was used to estimate utility values for three health states among CRC patients with liver metastasis undergoing hepatic resection [218].

HRQoL measured directly from patients is not always possible in mCRC, and around 30 carers were used a number of times as a proxy because terminally ill mCRC patients would have difficulties in understanding SG or TTO techniques [209, 220, 236-238]. A summary of HSUVs associated with CRC treatments and AEs are presented in Table 4.4.

Table 4.4 HSUVs associated with CRC treatments and AEs

Valuation methods	Health states and reported HSUVs	Reference
EQ-5D	[1 st line] Panitumumab+FOLFOX4 0.778; FOLFOX4 0.756 [2 nd line] Panitumumab+FOLFIRI 0.769; FOLFIRI 0.762	Bennett (2011) [244]
TTO	[CRC patients; community members] Remission [0.83; 0.82] Adjuvant, no neuropathy [0.61; 0.60] Adjuvant, mild neuropathy [0.61; 0.51] Adjuvant, moderate neuropathy [0.53; 0.46] Adjuvant, severe neuropathy [0.48; 0.34] Metastatic, stable [0.40; 0.51], Metastatic, progressive [0.37; 0.21]	Best (2010) [194]
TTO	FOLFOX+'new drug'→FOLFIRI→BSC until death [2-33 months] 0.68-0.89 FOLFOX→FOLFIRI→BSC until death [2-32 months] 0.70-0.94	Dranitsaris (2011a)** [238]
TTO	FOLFOX±'new drug' → FOLFIRI → BSC until death [2-29 months] 0.67-0.83 FOLFOX→FOLFIRI→BSC until death [2-32 months] 0.72-0.91	Dranitsaris (2011b)** [237]
TTO	FOLFOX+'new drug'→FOLFIRI→BSC until death [2-29 months] 0.52-0.84 FOLFOX→FOLFIRI→BSC until death [2-32 months] 0.53-0.84	Dranitsaris (2012a)** [236]
TTO	FOLFOX+'new drug'→FOLFIRI→BSC until death [2-28 months] 0.44-0.72 FOLFOX→FOLFIRI→BSC until death [2-32 months] 0.44-0.71	Dranitsaris (2012b)** [220]
EQ-5D	Metastatic disease 0.820 Palliative care 0.643	Farkkila (2013) [239]
HUI3	Cetuximab+BSC 0.71-0.77 BSC 0.66-0.71	Mittmann (2009)** [221]
EQ-5D	[Panitumumab plus BSC; BSC alone] Overall [0.72 ; 0.68] Wild-type KRAS [0.73 ; 0.68] Mutant KRAS [0.71 ; 0.68]	Odom (2011) [246]
SG	Partial response 1.0; Stable disease 0.95 Progressive disease 0.575; Terminal disease 0.1	Petrou (1997)* [209]
TTO	XELOX without AEs 0.59 ;FOLFOX without AEs 0.53 Febrile neutropenia 0.39; Nausea/vomiting 0.38 Diarrhoea 0.42; Hand-foot syndrome 0.39; Fatigue 0.45 Peripheral neuropathy 0.45; Stomatitis 0.42	Shiroiwa (2009) [232]
EQ-5D	[Panitumumab + BSC; BSC] TOX [0.6008; 0.4409], TWiST [0.7678; 0.6630], REL [0.6318; 0.6407]	Wang (2011) [248]
EQ-5D	Disease-free 0.78; Non-curative 0.67; Recurrence 0.74 Recurrence with chemotherapy 0.82 Recurrence without chemotherapy 0.68	Wiering (2011) [217]
EQ-VAS	Baseline 61.76 (SD 23.15) Cycle 2 68.59 (SD 22.26) [p=0.06] End of study 66.54 (SD 23.18) [p=0.29]	Ward (2014) [203]

*Reported HSUVs are re-expressed on a 0-1 scale; ** Ranges of reported HSUVs; **AE(s)** adverse event(s); **BSC** best supportive care; **CRC** colorectal cancer; **FOLFOX** Oxaliplatin + infusional 5 fluorouracil (5-FU); **FOLFIRI** Irinotecan + infusional 5 fluorouracil (5-FU); **FOLFOX4** 5-fluorouracil/ folic acid and oxaliplatin; **HSUV** health state utility value; **KRAS** Kirsten rat sarcoma viral oncogene; **REL** (relapse period until death or end of follow-up); **SD** standard deviation; **SG** Standard gamble; **TOX** days with ≥ grade 3 adverse events; **TTO** time trade-off; **TWIST** time without symptoms or toxicity; **XELOX** capecitabine plus oxaliplatin

Ness and colleagues (1999a) [174] reported much lower HSUVs for mCRC than did other studies [199, 200]. People who previously underwent the removal of colorectal adenomas assigned a much lower value to mCRC of 0.25 [174] compared to CRC survivors, 0.81 [199] and 0.85 [200]. CRC patients assigned relatively higher values to mCRC (0.820) and palliative care (0.643) compared to those who had no history of previous or current CRC [239]. Stable and progressive disease states were given a much higher value using SG by people who had colorectal adenomas removed [192] compared with those to CRC using TTO [194].

Table 4.5 HSUVs in CRC

Valuation methods used	Reported HSUVs	Reference
SG	Stage I 0.74 Stage II 0.74 (0.59*) Stage III 0.67 (0.59*) Stage IV 0.25	Ness (1999a) [174]
HUI3	Stage I 0.84 Stage II 0.86 Stage III 0.85 Stage IV 0.84	Ramsey (2000) [199]
HUI3	Stage I 0.83 Stage II 0.86 Stage III 0.87 Stage IV 0.81	Ramsey (2002) [200]
EQ-5D	Dukes stage A+B 0.786 [§] Dukes stage C+D 0.806 [§]	Wilson (2006) [211]
SF-6D	Stage I 0.831 Stage II 0.858 Stage III 0.817 Stage IV 0.732	Wong (2013b) [190]

*Rectal cancer; **SG** Standard gamble; [§]Re-expressed on a 0-1 scale; **FACT-C** Functional Assessment of Cancer Therapy-Cancer

Of five studies reporting HSUVs of different CRC stages, HSUVs were clustered ranging from 0.732 to 0.87 [199, 200, 211, 224] with an exception of one study 0.25 to 0.74 [174] . A summary of selected HSUVs in different CRC stages is presented in Table 4.5.

4.2.5 Discussion

There is no shortage of HSUVs available for those wishing to estimate the cost-effectiveness of diagnostic and treatment strategies with respect to CRC. Those assessing cost-effectiveness face a number of challenges: first, justifying their selection of values when there is no set of values that are clearly superior to all others, and second, negotiating trade-offs between the advantages and disadvantages of the available values.

This choice can be simplified where there is an agreed hierarchy regarding the appropriateness of different approaches to generating HSUVs. In order to aid resource allocation and decision making within a tax-funded healthcare system economic evaluation needs population values for specific health states related to CRC. Thus, the preferences of the public are generally deemed appropriate when health services are largely paid for by taxpayers [255]. Some agencies have a preference for generic PBMs being used to report the experience of patients in the trial from which the effectiveness of the treatment is being estimated when deciding whether or not to recommend a new treatment, or in the absence of such data similar measures reported in the literature would be used [191].

Researchers usually confront a series of trade-offs and must make judgements about the importance of having all HSUVs used in an economic evaluation come from the same source, or at least obtaining all the HSUVs using the same methods. The number of HSUVs required will in part depend on where in the clinical pathway the intervention being assessed is located. The earlier in the pathway, the larger the number of potentially relevant health states and the less likely it is that all the required HSUVs can come from a single study. Even with clear preferences over the type of measure and the source of values, the decision over which values to use can be challenging since the ranking of methods or sources might change in particular circumstances. For example, trial data is not always to be preferred to observational data, if the latter provide much larger numbers of observations and are more representative of patients in routine clinical practice. Also a directly collected generic PBM might not always be preferred to the same measure obtained through mapping, for example, if the latter allowed the valuation of a wider range of CRC-related health states. It is uncertain if HSUVs related to mCRC valued by CRC survivors are more relevant than those by health care professionals when making decisions. Also, the issues of whether or not HSUVs for mCRC valued by early CRC patients are more reliable than those valued by patients with different types of metastatic cancer, has received little attention.

HSUVs have been measured by a surrogate group such as oncology nurses, pharmacists or other health care professionals [209, 220, 236-238]. Despite limitations to the study design (such as small sample size or under-explored uncertainties) these HSUVs continue to be used in economic evaluation studies associated with CRC [209]. Subsequently, these uncertainties are inherited by

the estimation of cost-effectiveness and of QALYs. Well-designed clinical studies continue to generate new evidence that is highly focussed on treatment effects with strong internal validity. Economic evaluation would be strengthened if health state data could be taken from the clinical studies that provide the estimates of effectiveness of treatment [256]. Further research which utilises data from patient-reported outcomes and population surveys cancer registry data in assessing HRQoL and HSUVs is recommended [257].

Given the absence of generic PBM data from many trials, existing mapping algorithms could be more fully utilised as an additional means of deriving HSUVs for economic evaluation of CRC, and also exploratory studies to derive HSUVs from EORTC QLQ-C30 data using the EORTC-8D or QLU_C10D are warranted.

Although there are a number of algorithms for mapping from cancer-specific scales to generic PBMs, this approach has not been frequently reported with respect to CRC. Cancer-specific scales, such as the QLQ-C30, capture a number of clinical and domain-specific effects that might not be captured when using generic PBMs [258]. Mapping also has the advantage of producing QALYs measured using a familiar metric. However, any mapping inevitably introduces additional uncertainty to the QALY calculation and the cost-effectiveness estimation.

Important questions associated with HSUVs for the economic evaluation of CRC remain unanswered. What is the most accurate way of measuring and valuing HRQoL in CRC? Is it better to collect HRQoL data directly from a small number of CRC patients over a follow-up period? The studies reviewed gave limited consideration to the best way to measure and value CRC health states [216].

This review highlights gaps in the evidence and opportunities for informative research. The most appropriate way to measure and value CRC-related health states should be studied. Developing a set of criteria for selecting the most appropriate HSUVs that fits the analyst's purpose is encouraged. It is not known whether the mCRC-related HRQoL of CRC survivors is more representative than those derived from a small surrogate group. Also, whether mCRC-related HSUVs valued by early CRC patients are more appropriate than those valued by patients with different types of metastatic cancer for economic evaluation has been under-researched. HSUVs play an integral role in economic evaluation. Methods of exploring and addressing uncertainties associated with the HSUVs chosen for economic evaluation should be studied.

4.2.6 Conclusion

CRC-related HSUVs vary markedly between studies and across methods. Despite the number of HSUVs published, there is not a set of HSUVs that are methodologically robust with a full range of values for health states of interest appropriate for the use in economic evaluation of CRC. There is considerable scope for new HSUVs to be developed which improve on those currently available and consequently to produce better estimates of QALYs and cost-effectiveness, in order to better inform resource allocation and healthcare decision making. In addition, the use of existing mapping algorithms to derive CRC-related HSUVs should be further explored.

5 COST-EFFECTIVE STRATEGIES FOR PEOPLE WITH CONFIRMED ADENOMAS IN THE PREVENTION AND EARLY DETECTION OF COLORECTAL CANCER IN COLORECTAL CANCER SCREENING, NATIONAL HEALTH INSURANCE IN KOREA

5.1 Preamble to Research Paper IV

Gaps in the CRCS and the need for cost-effective evidence for the early detection and prevention of CRC were presented in Chapters 2-4. The focus of this chapter is the identification of cost-effective strategies for COL surveillance for the prevention and early detection of CRC in Korea. This will be achieved by developing an economic model and estimating the cost-effectiveness of COL surveillance strategies by utilising findings from Chapters 2-4:

- 1) Adenoma recurrence rates post-polypectomy, resources used in COL surveillance and CRCS and CRC treatment were estimated through the short-term analysis of the CRCS in NHS, Korea, 2009-2012 (CRC cohort, Chapter 2).
- 2) The review of relevant cost-effectiveness evidence of COL surveillance and CRCS provided evidence on the common approaches taken in economic modelling, test modalities comparison, the follow-up strategies and down-stream effects in the published literature [100]. A further search of databases was undertaken in order to capture cost-effectiveness evidence in a Korean context

that might be relevant. The search confirmed there was no cost-effectiveness evidence for people with adenomas in the prevention and early detection of CRC (Chapter 3), therefore the construction of a *de novo* model was necessary to address the research questions posed in this thesis. Findings from the review informed for the potential modelling approaches of the economic evaluation of COL surveillance in the CRCS, NHI in Chapter 5.

3) Health outcomes relevant to CRCS and CRC for the cost-utility analysis were identified through a systematic review of relevant HSUVs of CRCS and CRC [259]. Results from the systematic review (Chapter 4) informed in the choice of methodologically sound HSUVs of CRC for the economic model in Chapter 5.

4) Also identified were cost-effectiveness evidence of COL surveillance and CRCS and HSUVs for CRC and CRCS in the context of Korea that informed a *de novo* cost-utility analysis of COL surveillance in the CRCS, NHI Korea (Chapter 5).

Research Paper Cover Sheet – Research Paper IV

London School of Hygiene & Tropical Medicine
Keppel Street, London WC1E 7HT
www.lshtm.ac.uk

Registry
T: +44(0)20 7299 4846
F: +44(0)20 7299 4856
E: registry@lshtm.ac.uk

LONDON
SCHOOL OF
HYGIENE
& TROPICAL
MEDICINE



RESEARCH PAPER COVER SHEET

PLEASE NOTE THAT A COVER SHEET MUST BE COMPLETED FOR EACH RESEARCH PAPER INCLUDED IN A THESIS

SECTION A- Student Details

Student	Kim Eyoung Jeong
Principal Supervisor	Professor John Cairns
Thesis Title	Cost-effective strategies in the follow-up of people with confirmed colorectal adenomas for the prevention and early detection of colorectal cancer in the National Health Insurance, South Korea

If the Research Paper has previously been published please complete Section B. if not please move to Section C

SECTION B – Paper already published

Where was the work published?	
When was the work published?	
If the work was published prior to registration for your research degree, give a brief rationale for its inclusion	
Have you retained the copyright for the work?*	Choose an item. Was the work subject to academic peer review?

If yes, please attach evidence of retention. If no, or if the work is being included in its published format, please attach evidence of permission from the copyright holder (publisher or other author) to include this work.

SECTION C – Prepared for publication, but not yet published

Where the work intended to be published?	Peer-review journal (to be decided)
Please list the paper's authors in the intended authorship order:	Kim Jeong, John Cairns
Stage of publication	Not yet submitted

SECTION D – Multi-authored work

For multi-authored work, give full details of your role in the research included in the paper and in the preparation of the paper. (Attach a further sheet if necessary)	See next page.
--	----------------

Student Signature: _____

Date: _____

Supervisor Signature: _____

Date: _____

Title: Cost-effective strategies for people with confirmed adenomas in the prevention and early detection of colorectal cancer in colorectal cancer screening, National Health Insurance, Korea

Authors: Kim Jeong, John Cairns

Affiliation:

Department of Health Services Research and Policy, London School of Hygiene and Tropical Medicine, London, UK

Candidate's contribution: Under the guidance of supervisor (and co-author), the design and construction of an economic model, further searches of databases, a series of sensitivity analyses and the management of data were undertaken by the candidate. The first draft of the manuscript was written by the candidate.

5.2 Research paper IV Cost-effective strategies for people with confirmed adenomas in the prevention and early detection of colorectal cancer in colorectal cancer screening, National Health Insurance, Korea

5.2.1 Abstract

The aim of cost-utility analysis is to identify the most cost-effective strategies and to estimate the cost-effectiveness of follow-up colonoscopy (COL) options for colorectal cancer screening to inform the follow-up COL policy within the current colorectal cancer screening programme (CRCS) in the National Health Insurance (NHI) in Korea. A state transition model simulated the life experience of a cohort of individuals with confirmed colorectal adenomas, utilising results from short-term analysis of CRCS in Korea (2009-2012, CRC cohort). Different intensities of COL surveillance were compared to No COL surveillance. Gaps in the evidence were complemented with the most relevant published evidence. A 0LR3HR strategy (that is COL offered to those in the high risk group every 3 year) appears to be the most cost-effective strategy, given a cost-effectiveness threshold of Korean Won 30,000,000 per QALY gained. The base-case result was sensitive to the cost of COL if it was set at as high as the cost of COL in the United States, otherwise it remained constant with the base-case results through a series of sensitivity analyses. A full pathway modelling of CRCS linking the existing CRCS and COL surveillance by utilising CRCS and NHI data would provide further insights of the costs and benefits of CRCS in the NHI.

Keywords

Colorectal cancer; screening; surveillance; cost-effectiveness; colonoscopy, QALY

5.2.2 Introduction

Colorectal cancer (CRC) is the third most common cancer in South Korea (hereafter, Korea) [48]. Indirect evidence suggested that the transformation of colorectal adenomas into carcinoma takes 10-15 years. The interruption of the adenoma-carcinoma sequence and the removal of the precursor of CRC (polypectomy) reduces the incidence of CRC [51]. Screening for CRC is offered routinely to individuals who are 50 years or older as part of the National Cancer Screening Programme (NCSP) in the National Health Insurance (NHI), Korea. There is limited cost-effectiveness evidence on the CRCS and follow-up strategies and further search was undertaken utilising published search strategies in order to identify economic evidence in the prevention and early detection of CRC for individuals with confirmed adenomas [100]. Of the five eligible studies identified, one was partially applicable despite limitations [260] and four studies were excluded [11, 261-263] due to severe limitations identified through a critical appraisal (see Appendix Tables A5.1.1-A5.1.2) [98]. There is a paucity of cost-effectiveness evidence regarding the intensity of colonoscopic surveillance (COL surveillance) in CRCS in the NHI, Korea, therefore a *de novo* economic analysis is needed. The focus of this economic analysis is marked with the green dotted in the Figure 5.1 (Reproduced from Figure 1.7 in section 1.6 of Chapter 1).

Figure 5.1 Gaps in the current CRCS NHI [Reproduced from Figure 1.7, section 1.6 of Chapter 1]

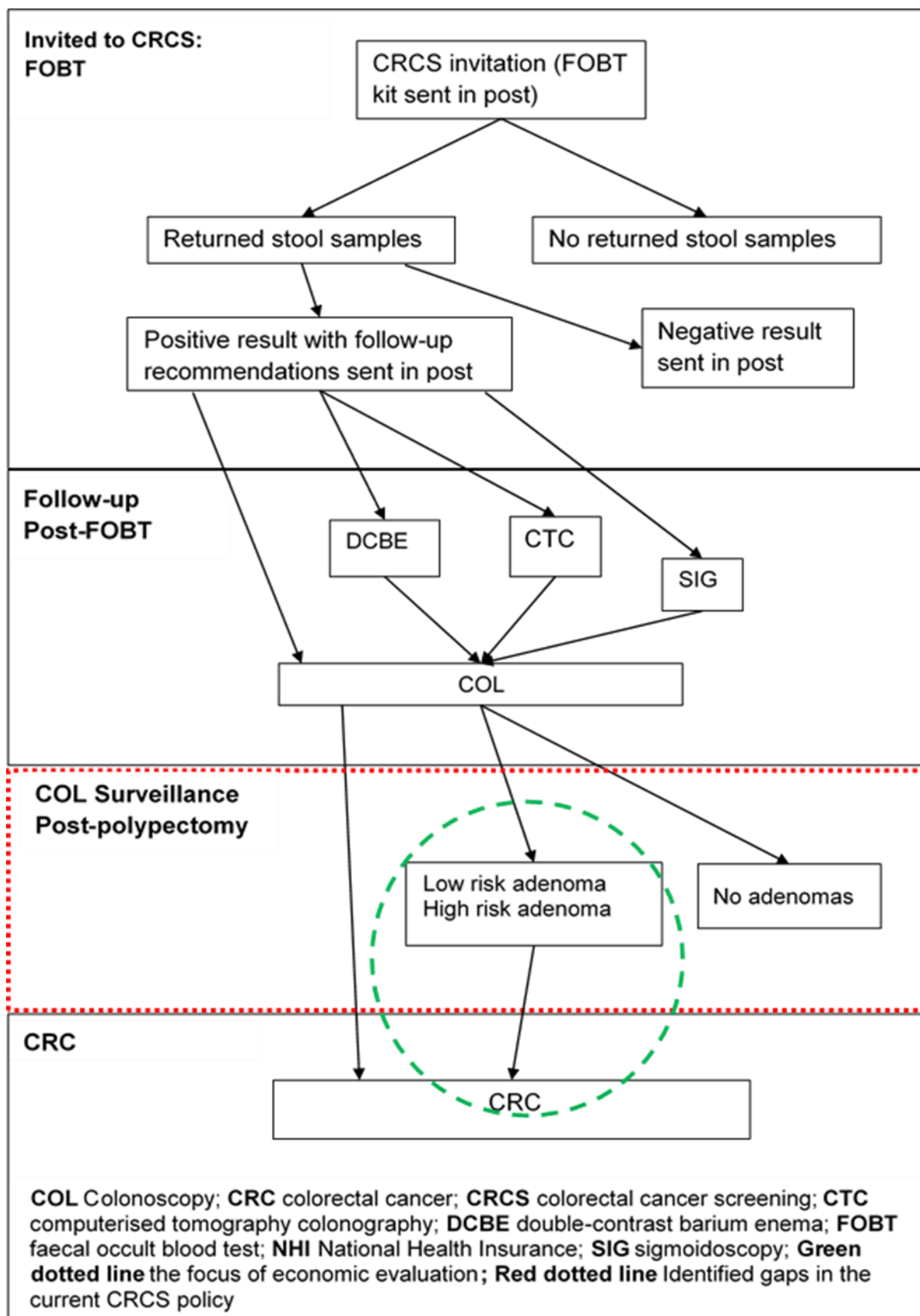

Evidence associated with the true incidence rate of adenomas is limited in Korea [64]. Existing studies focused on people having COL surveillance tend to overestimate the prevalence of adenomas because study participants were likely to be at a higher risk of developing CRC than the general population. Index COL, defined as the most recent COL performed by an experienced specialist colonoscopist, is performed in order to remove detected polyps/adenomas and to establish risk status [24, 67, 69, 70]. The size of adenomas, the degree of dysplasia and the presence of villous features are then used in determining the individual's risk status [21, 67]. The number of adenomas removed during a COL is not currently reported in the CRCS (see Appendix Figure A5.1). Instead, the number of biopsies taken during a COL is reported, this is clustered into 5 groups in the reporting template of CRCS. Therefore, the number of biopsies taken during a COL is used as the proxy for the number of adenomas being removed during a COL. In the model, low risk (LR) was defined as 1-3 adenomas or adenoma <10 mm or low-grade dysplasia; and high risk (HR) was defined as 4 or more adenomas, adenoma >10 mm or high-grade dysplasia (see Table 5.1).

Table 5.1 Reported COL findings from CRCS and risk stratification in the model [Reproduced from Table 2.7 section 2.2.5 of Chapter 2]

Reported COL findings from CRCS (CRC cohort)			<i>*Approximated risk stratification for the economic model</i>
Reported size of adenomas			
<10 mm			LR
≥10 mm			HR
Reported numbers of adenomas			
Number of adenomas	Reported number of biopsies taken for pathology/ histology	Reported numbers of biopsies	
Not reported	1-3	Group 1	LR
Not reported	4-6	Group 2	HR
Not reported	7-9	Group 3	HR
Not reported	10-12	Group 4	HR
Not reported	13 or more	Group 5	HR
Reported degree of dysplasia in adenomas		LGD	LR
		HGD	HR

COL colonoscopy; **CRC cohort** short-term analysis of the CRCS in NHI, Korea, 2009-2012; **CRCS** colorectal cancer screening; **HGD** high-grade dysplasia; **HR** high risk **LGD** low-grade dysplasia; **LR** low risk; * approximated risk stratification was carried out using the CRC cohort data for the economic model in Chapter 5

There are discrepancies in the risk stratification of adenomas between the CRC cohort and the existing Korean clinical guidelines. For example, when considering the number of adenomas, based on the data in the CRC cohort, group 1 included those with 1-3 adenomas, therefore this group was assigned as LR (see Table 5.1), in contrast, the Korean clinical guidelines defined LR as having 1-2 adenomas (see Table 5.2). Therefore, LR in the CRC cohort inevitably includes individuals with 3 adenomas that would have been in a HR group in the existing clinical guidelines in Korea. This was inevitable because the number of biopsies taken during a COL was reported in terms of groups 1 to 5 (Table 5.1). This would potentially lead to differences in the estimation of the risk of adenoma recurrence post-polypectomy.

Table 5.2 Discrepancies in the risk stratification of adenomas and identified gaps in the recommendations and current practice [Reproduced Table 1.7, section 1.6 of Chapter 1]

LR	HR	Initial interval (year) of a follow-up COL post-polypectomy	Subsequent interval of COL follow-up COL finds adenomas	References
Without any HR findings at index COL	3 or more adenomas or any adenoma larger than 10 mm or any tubulovillous or villous adenoma or any adenoma with HGD or any serrated polyps larger than 10 mm	5LR3HR (5 years for LR; 3 years for HR)	Not specified	Yang (2012) [24] Hong (2012) [67]
Not specified	In patients with alarming symptoms or with a high risk of interval cancer	5LR HR≤5 (less than 5 years)	Not specified	Lee (2012) [40]
Any adenomas without HR	3 or more adenoma or adenoma > 10 mm or HGD or any tubulovillous or villous adenoma	1HR	Not specified	Jung (2012) [77]
6 mm tubular adenoma or two 6 mm tubular adenomas	12 mm tubular adenoma with HGD 12 mm tubulovillous adenoma	LR ≤1 (less than 1 year); 3LR; 5LR HR≤1; 3HR; 5HR	Not specified	Sohn (2014) [72]
Not specified	<1 cm adenoma >1 cm or multiple adenomas	After 3 years After 1 year	Not specified Not specified	NCC (2015) [264]
Not specified	Not specified	Not specified	Not specified	NHIS (2014) [31]
1-2 adenomas <10 mm	3 or more adenomas or ≥10 mm or > 25% villous structure or HGD	3HR	Not specified	Chung (2011) [69]

COL colonoscopy; **HGD** high-grade dysplasia; **HR** high risk; **LR** low risk; **NCC** National Cancer Centre; **NHIS** National Health Insurance Service

In a survey it was found that more than 50% of practitioners did not follow recommended COL surveillance or chose different guideline recommendations, and practitioners were reported to advise individuals in HR or LR to return for a follow-up COL in 1 year, in 3 or 5 years regardless of risk status (see Table 5.2) [72].

The focus of this economic model is to identify the most cost-effective COL surveillance strategy in the current CRCS for people with confirmed adenoma(s) (see Figure 5.1). Currently, there is no evidence on the cost-effectiveness of COL surveillance strategies based on the risk status [24]. Furthermore, the intensity of COL surveillance is largely dependent on the clinician's opinion [40, 72]. Therefore, the intervention strategies considered in the economic model varied the intensity of COL surveillance. The comparator strategy considered in the model was no COL surveillance, and individuals with confirmed adenomas continued to be invited to annual CRCS.

5.2.3 Methods

Model overview

CRCS is offered to those 50 years and older up to the age of 80 [64]. A time horizon of 50 years was chosen to capture all important costs and benefits between the different intensities of COL surveillance [83]. A yearly cycle in the model is generally recommended, however, a quarterly cycle was chosen for this model as this allows movements between states (transitions) in between the states in the COL surveillance model [83]. This was reasonable when an annual COL is one of the comparators considered in the model.

At the HIRA, in the decision making process there is no explicit cost-effectiveness threshold. However, on a number of recent occasions a threshold of KRW 30,000,000 per QALY gained was said to be used which is higher than the previous threshold of KRW 20,000,000 per QALY gained in NHI (personal communication). Key features of the economic analysis were addressed following the guideline by the HIRA, other guidelines for economic evaluation are considered where there were gaps (see Table 5.3) [83, 265].

Table 5.3 Key features of the economic analysis

Element	Chosen approaches/ values	Reference
Population	<ul style="list-style-type: none"> • 50 years and older without current CRC or previous history of CRC treatments AND • had a positive FOBT result as part of CRCS AND • had a COL and the removal of adenomas (polypectomy) as part of CRCS 	CRC cohort NHIS (2014) [31]
Interventions	<ul style="list-style-type: none"> • A COL 5 years post-polypectomy for LR and 3 years for HR [5LR3HR] • 5LR1HR • 5LR2HR • 1LR1HR • 3LR1HR • 3LR3HR • 0LR1HR • 0LR2HR • 0LR3HR 	Hong (2012) [67] Yang (2012) [24] Kim (2012) [71] Lee (2012) [40] Sohn (2014) [72] Jung (2012) [77] CRC cohort NCC (2015) [15] Sohn (2014) [72] Chung (2011) [69]
Comparator	No COL surveillance (0LR0HR) within CRCS	CRC cohort
Starting and ceasing COL surveillance	COL surveillance offered to individuals 50-80 years old	NHIS (2014) [31] Sohn (2015) [64]
Outcomes	Cost per QALY gained	HIRA (2011) [83]
Time horizon	50 years	HIRA (2011) [83]
Modelling approach	Cohort modelling with state transition using Microsoft Excel®	HIRA (2011) [83]
Type of economic analysis	Cost-utility analysis	HIRA (2011) [83]
Cycle length	Quarterly (yearly cycle is recommended)	HIRA (2011) [83]
Measuring health effects	QALY	HIRA (2011) [83]
Discount for costs and benefits	5% in base-case analysis 0%, 3.5% and 7% in sensitivity analyses	HIRA (2011) [83]
Perspective of analysis	NHI; societal	HIRA (2011) [83]
Perspective on costs	NHI; societal	NICE (2014) [265]
Currency and price data	KRW, year 2015	HIRA (2011) [83]
Perspective on outcomes	All direct health outcomes	NICE (2014) [265]
Synthesis of evidence on outcomes	Based on the short-term analysis of CRCS and relevant published evidence	HIRA (2011) [83]
Valuating health effects	Preference based measure	HIRA (2011) [83]
Source of data for measurement of QoL	Reported directly by people using service and/or carers where possible	HIRA(2011) [83]
Source of preference data for valuation of changes in HRQoL	Representative sample of the Korean population where possible	HIRA (2011) [83]
Evidence on resource use and costs	Direct costs of COL surveillance, CRC diagnosis and treatment	HIRA (2011) [83] CRC cohort
WTP threshold	KRW 30,000,000 per QALY gained	Personal communication

COL colonoscopy; **CRC** colorectal cancer; **CRC cohort** short-term analysis of the CRCS in NHS, Korea, 2009-2012 (Chapter 2); **CRCS** colorectal cancer screening; **FOBT** faecal occult blood test; **HIRA** Health Insurance Review & Assessment; **HR** high risk; **HRQoL** health-related quality of life; **KRW** Korean Won; **LR** low risk; **NICE** National Institute for Health and Care Excellence; **NHI** National Health Insurance; **QALY** quality-adjusted life year; **QoL** quality of life; **WTP** willingness-to-pay

A Markov model was developed which incorporated recurrent adenomas and the requirements of lifelong COL surveillance post-polypectomy in a cohort using a commonly accessible software, Microsoft Excel®. There are three parts in the economic model: adenoma-carcinoma, COL surveillance and CRC treatments with the corresponding health-related quality of life (HRQoL) data in each health state. This was to differentiate the different diagnostics and successive early detection of asymptomatic CRC through COL surveillance in CRCS, compared to the presentation of symptomatic CRC without COL surveillance. In the model, it is assumed that individuals who are diagnosed with CRC receive identical treatments depending on the disease state regardless of the means of CRC detection [51, 265, 266]. The effectiveness of COL surveillance was modelled as an intervention to determine cost-effectiveness of COL surveillance for the early detection and prevention of CRC in the CRCS, NHI in Korea.

In the model, COL surveillance was assumed to be offered to individuals aged between 50 and 80 years who had confirmed adenomas at the index COL in the current CRCS policy in the NHI [31, 64]. It was assumed that all adenomas were detected and removed at the index COL and COL surveillance. The long-term outcome of the COL surveillance model captured the benefits of the different intensities of COL strategies, in order to detect and remove adenomas before developing to carcinomas. All CRCs were assumed to arise from adenomas. Therefore, the early detection of adenoma and its subsequent removal, and the early detection of CRC would impact on the health benefits and costs of each strategy compared to no COL surveillance in the model.

Adenoma-carcinoma: natural history

The basis of the economic model has two parts: adenoma recurrence for COL surveillance model and adenoma-carcinoma sequence. The proportion of LR and HR groups was determined at the initial starting point of the model, 87.5% and 12.5% respectively, based on the findings from the CRC cohort (Chapter 2). Adenoma recurrence rates were derived from the short-term analysis of CRCS, 2009-2012 (section 2.2 of Chapter 2). The rate at which adenomas develop into CRC remains uncertain [39, 96]. The calculation of time at which adenomas become CRC was not feasible utilising the short-term follow-up of the data (2009-2012) because of the limited information available from the CRC cohort.

Various approaches can be considered in modelling the adenoma-carcinoma sequence. These include modelling the growth of individual adenomas; the number, size, type and location of adenomas, a progression from non-advanced to advanced adenomas, and the progression of LR adenomas to HR adenomas. The potential approach of modelling for the planned CUA (Chapter 5) was to incorporate available evidence from the CRC cohort (Chapter 2) with the use of best possible evidence identified from the review of economic evidence (Chapter 3) to compliment gaps in the evidence related to the adenoma-carcinoma. Very limited data were available on transition rates post-polypectomy; there was considerable uncertainty surrounding the modelling of surveillance.

Saini (2010) [76] calculated the relative risk of adenoma recurrence by utilising the NPS study [51] and the annual probability of developing CRC from adenomas by utilising a registry-based study [267]. Tappenden (2007) [79] obtained estimates of adenoma-carcinoma sequence using a calibration method, and the approach and estimates from the study were adopted in the subsequent studies

[99, 102]. From the original options appraisal by Tappenden (2007) [79], Whyte (2012) [96] applied an improved calibration to estimate the natural history of adenoma-carcinoma model parameters derived from large screening data sets from England, Italy, Germany and Korea [39, 43, 267-270]. Adenomas and CRC prevalence may vary by country, but the extent of this variation and related uncertainties remained unknown. The value of using data from more than one country was that it allows the use of large data sets from several screening modalities. The definitions used in the risk stratification of adenomas differed between countries, with the English Bowel Cancer screening data low/intermediate/high risk adenomas according to BSG guidelines, and the Italian and German screening data reporting advanced adenomas. In order to include these data sources within the calibration process, an adjustment had to be made to estimate the proportion of advanced adenomas that would be classified as HR. This adjustment was crude as it was based on a small data set, so it introduced uncertainty into the modelling. Overall, the benefit of including large data sets on different screening modalities was considered to outweigh the uncertainty associated with using data sets from different countries. Therefore, the reported estimates of adenoma-carcinoma [96] were considered best evidence to inform the economic model alongside the estimates of adenoma recurrence post-polypectomy from the CRC cohort. (Chapter 2). See the quality appraisal of the study [96] in the Appendix Table A5.2. This is one of the limitations of this economic analysis.

It was assumed that an individual with Dukes' B, C, or stage D CRC was more likely to present symptomatically than an individual with Dukes' A CRC. Clinically plausible ranges describing the probability of symptomatic presentation with CRC

were taken from an existing study [96]. Crude estimates of CRC and non-CRC mortalities were derived from the CRC cohort and published statistics [2].

COL surveillance model

Two mutually exclusive diagnostic states post-polypectomy, LR and HR, were modelled in the Markov model. These states only differ in terms of the intensity of COL surveillance. Any movement between two diagnostic states is through either COL surveillance or symptomatic presentation of CRC in the model. Identified diagnostic health states, LR and HR, and the four CRC disease states were mutually exclusive in the model (see Figure 5.2). The removal of adenomas through COL surveillance was linked to the early detection of CRC and reduction in CRC related mortality compared with symptomatic CRC without COL surveillance. Tunnel states were used to model differences in the probability of recurrence post-polypectomy between the first and second year and onward, in order to add time-dependency to the memory-less Markov model based on the findings from the CRC cohort [271]. In the model, there was no death due to Dukes' A CRC. Transitions from adenoma free to adenoma recurrence and adenoma free were modelled in the COL surveillance (blue dotted circle in Figure 5.2) and relevant transition probabilities for transitions were summarised in Table 5.4. In the HR group, individuals with no HR findings in the next COL surveillance will be 'down-graded' to an interim risk group, then exit COL surveillance after no LR or HR findings in two consecutive rounds of COL surveillance. When there is no LR finding from COL surveillance, individuals in the LR group exit COL surveillance and return to CRCS. In the case of HR findings from COL surveillance, individuals in the LR group will be moved to the HR group (see

Figure 5.2). In the model, there was no death due to CRC from Dukes' A CRC. Relevant costs and benefits for those exiting COL surveillance were included in the costs and benefits of each strategy.

Figure 5.2 Outline of the economic model

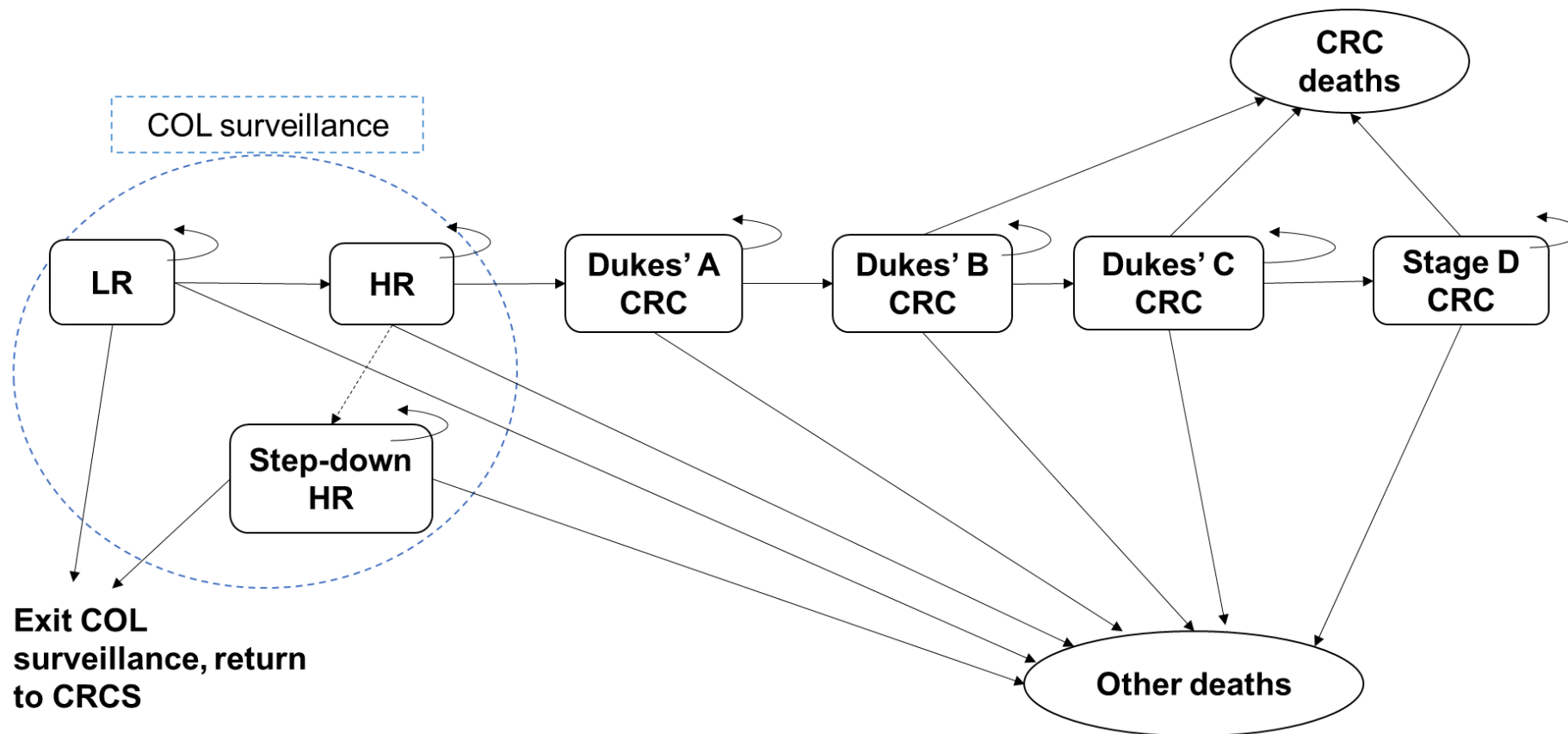

COL colonoscopy; LR low risk; HR high risk; CRC colorectal cancer; CRCS colorectal cancer screening

Poor uptake in the CRCS presented in Chapter 2 was specific to the initial invitation to FOBT. The uptake of FOBT was not important in the CUA of COL surveillance because FOBT was a step before the COL surveillance and differential uptake of FOBT does not directly affect the cost-effectiveness of COL surveillance. It was assumed that there was no dropout from the COL surveillance because: 1) there was very limited evidence regarding compliance with the initial and subsequent follow-up COLs [100]; 2) there was a high level of interest and increase in compliance among Koreans when they were informed of an increased risk of developing CRC (personal communications); 3) practitioners were often reported to advise shorter COL surveillance intervals than recommended by the guidelines [72]; 4) compliance to FOBT and initial follow-up COL has been reported but the subsequent COL compliance has never been estimated or reported even in the most recent report utilising NHIS data from 2003 – 2013 [8].

While it is obvious that there will be some dropout from COL surveillance, the exact figure and how this varies with each subsequent follow-up appointment is unknown. To account for this in the model will require further assumptions that will inevitably weaken the model outputs. Taking the increase level of interest in compliance and the shorter intervals noted above, any lack of compliance is expected to be very small.

It may be expected that a lack of compliance will decrease the costs related to COL, but increase the costs related to later diagnosis of CRC. While these factors move costs in opposite directions, the overall impact on cost will probably be an increase, though its exact magnitude cannot be estimated accurately.

Overall, the lack of compliance will decrease the QALY gain associated with screening as more people will develop avoidable CRC (COL detected CRC). therefore, one can expect that any lack of compliance will make the screening programme less cost effective overall. If the compliance to FOBT and CRCS dramatically improves in the future, the reported estimates of this economic model will be no longer valid.

The potential complications associated with a COL procedure were considered to be rare among clinicians and practitioners [264]. Only one case of bowel perforation was reported in 15,270 COL procedures performed in the Korean Polyp Registry (N=17,276) over the period of April 2007 – November 2009 [272]. Given the very small probability of bowel perforation caused by a COL procedure and the lack of separate reporting of COL-related adverse events in the CRCS, it is assumed that there are no adverse events associated with a COL in the COL surveillance model.

CRC disease model

The CRC disease stages are frequently classified using different methods including Tumour-Node-Metastasis (TNM) staging or Dukes' stages (see Appendix Table A5.3) [91, 92]. The CRC stages were modelled using Dukes' stages and the transitions between CRC disease states were taken from a published study [96]. The transitions between health states were only allowed through a stepwise progression (see Figure 5.2). The main limitation of using a stepwise progression is the lack of face validity. However, a stepwise progression allows the modeller to incorporate uncertainty into a Markov model with a number of defined health states.

Transition probabilities associated with adenoma recurrence post-polypectomy were derived from the CRC cohort analysis as the CRC cohort represents the Korean population (see Appendix Tables A5.4.1-5.4.3). Given the limited data available regarding transition probabilities for CRC disease states, these were taken from a cost effectiveness analysis of CRC screening in the UK context [96]. The annual transition probabilities are converted into 3-monthly probabilities in order to fit the chosen cycle length in the model [271]. A Dirichlet distribution in a Bayesian framework allows the calculation of transition probabilities by utilising both the prior beliefs (the prior) and observed data (likelihood) resulting in the probability distribution of an event (the posterior) for a PSA to address parameter uncertainty (see Appendix Tables A5.5.1 - A5.5.4) [273]. Summary of parameter inputs for transition probabilities are presented in Table 5.4.

Table 5.4 Summary of parameter inputs – transition probabilities

Parameter name	Base case	Distribution for PSA [271]	Reference
Proportion of LR:HR	87.5:12.5	NA	CRC cohort
Transition probabilities (3-monthly)			
LR to HR	0.002	Beta	CRC cohort
HR to Dukes' A CRC	0.0063	Beta	Whyte (2012) [96]
Dukes' A CRC to Dukes' B CRC	0.1633	Beta	Whyte (2012) [96]
Dukes' B CRC to Dukes' C CRC	0.2538	Beta	Whyte (2012) [96]
Dukes' B CRC to CRC death	0.0025	Beta	Whyte (2012) [96]
Dukes' C CRC to stage D CRC	0.2662	Beta	Whyte (2012) [96]
Dukes' C CRC to CRC death	0.0154	Beta	Whyte (2012) [96]
Stage D CRC to CRC death	0.1151	Beta	Whyte (2012) [96]
Adenoma free post-polypectomy (LR) to LR at year 1	0.0024	Beta	CRC cohort
Adenoma free post-polypectomy (LR) to LR at year 2	0.0084	Beta	CRC cohort
Adenoma free post-polypectomy (HR) to LR at year 1	0.0012	Beta	CRC cohort
Adenoma free post-polypectomy (HR) to LR at year 2	0.0037	Beta	CRC cohort
Probability of presenting Symptomatic Dukes' A CRC	0.0102	Beta	Whyte (2012) [96]
Probability of presenting symptomatic Dukes' B CRC	0.0484	Beta	Whyte (2012) [96]
Probability of presenting symptomatic Dukes' C CRC	0.1091	Beta	Whyte (2012) [96]
Probability of presenting Symptomatic Stage D cancer	0.2859	Beta	Whyte (2012) [96]

AF adenoma-free; **Age** age-dependent; **CRC** colorectal cancer; **CRC cohort** short-term analysis of the CRCS in NHS, Korea, 2009-2012 (Chapter 2); **CRC death** death due to CRC; **HR** high risk (4 or more adenomas/polyps or one adenoma ≥10 mm in diameter or high-grade dysplasia); **LR** low risk (1-3 adenomas <10 mm or low-grade dysplasia); **NA** not applicable; **PSA** probabilistic sensitivity analysis

Health states and selected HSUVs

As reported in section 3.4 Chapter 3, the search of economic evaluations of CRC showed that reported outcomes were limited to cost per CRC prevented and cost per life years gained in the Korean context [11, 274] except for one cost utility analysis using the quality-adjusted life years (QALY) as an outcome measure in

which the source of the HSUVs was not reported [261]. Despite the number of HSUVs published, there are few HSUVs that can be used in cost utility analyses of CRC that are methodologically robust with the range of health states of interest, therefore further search was undertaken in order to identify HSUVs for an economic model in a Korean context by utilising published search strategies and study selection criteria (Appendix Tables A5.6.1-A5.6.2) [259]. In the absence of directly relevant HSUVs for CRC in the Korean setting, a reported set of HSUVs from Hong Kong was chosen for the model because these reported values were methodologically robust with health states of interest for this economic model [190]. The quality of life in CRC patients with chemotherapy-induced peripheral neuropathy has been examined using the European Organisation for Research and Treatment of Cancer Quality of Life Group (EORTC QLQ) C30 and CRC specific (EORT QLQ-CR29) questionnaires in a Korean setting [275]. These reported EORTC QLQ-C30 values were mapped onto EQ-5D and considered in the sensitivity analysis. Details of the mapping algorithm are reported in Appendix Tables A5.6.3 to A5.6.4.

An adenoma-free post-polypectomy health state was used to represent time in which people remained adenoma-free while continuing in COL surveillance, as represented in the Figure 5.2 including LR, HR, Dukes' A, Dukes' B, Dukes' C and Stage D CRC health states. In the absence of directly relevant HSUVs for CRC among Koreans in a Korean setting, a set of HSUVs (Wong 2013b) was selected from the systematic review (Chapter 4) because it was methodologically robust with health states of interest for the economic model from a group of people with similar mean age to that of the CRC cohort. Reported HSUVs were multiplied with the time spent on each health state then were adjusted to the cycle

length of the model. Individuals with adenomas are usually asymptomatic, thus HSUVs for an adenoma-free health state and a recurrent adenoma health state were assumed to be same as the general public utility value of 0.856 at the age of 50 in Korea [276]. A COL is an invasive procedure and the preparations prior to and during a scheduled COL may potentially cause temporary discomfort and inconvenience. COL-related disutility of 0.0025 was assumed in the published surveillance models [76, 99]. Therefore, a COL-related disutility of 0.0025 was included in the model [277]. The utility of being in the HR (0.832) or LR (0.871) groups may be different from being adenoma-free or cancer-free, these utility decrements of LR and HR were considered in the sensitivity analysis [190].

Table 5.5 Summary of parameter inputs – Utility

Parameter name	Base-case	For SA / Distribution for PSA [271]	Reference
Cancer-free	Age-dependent 50-59 0.0856 (\pm 0.202) 60-69 0.812 (\pm 0.241) 70+ (\pm 0.369)	NA	Lee (2009) [276]
Undiagnosed asymptomatic CRC; Adenoma-free post-polypectomy	Age-dependent 50-59 0.0856 (\pm 0.202) 60-69 0.812 (\pm 0.241) 70+ (\pm 0.369)	NA	Assumption
LR	0.871	One-way SA	Wong (2013b)
HR	0.832	One-way SA	Wong (2013b)
Dukes' A CRC	0.831	Beta	Wong (2013b) [190]
Dukes' B CRC	0.853	Beta	Wong (2013b) [190]
Dukes' C CRC	0.817	Beta	Wong (2013b) [190]
Stage D CRC	0.732	Beta	Wong (2013b) [190]
Disutility associated with COL	0.0025		Assumption (Saini 2010, NICE 2011)

CRC colorectal cancer; **HR** high risk (4 or more adenomas/polyps or one adenoma \geq 10 mm in diameter or high-grade dysplasia); **LR** low risk (1-3 adenomas <10 mm or low-grade dysplasia); **NA** not applicable; **PSA** probabilistic sensitivity analysis; **SA** sensitivity analysis

HSUVs for CRC were selected which were methodologically robust with four CRC disease states (Dukes A, B, C and Stage D CRC) of interest for the CUA as presented in the Figure 5.2 (Wong 2013b). A probability of non-CRC related death was included for all health states in the model. Details of utility values for the economic model related to Figure 5.2 are provided in Table 5.5.

Resources and costs associated with COL surveillance and CRC

The relevant range of costs was first identified, then each item was measured and valued with the time horizon of 50 years in order to have all cost consequences of the COL intervention taken into account in the analysis [97]. The data from the CRC cohort is the primary resource used for the economic model. As the CRC cohort included reimbursement data at a Korean population level it has high external validity, however, it provided fewer details on the stage-specific CRC treatments.

COL in the CRCS is reimbursed at KRW 74,240 in 2014 [56]. Health service fees are set and revised annually by the MoHW, and the set rate was reported to be below the minimum costs of COL service delivery [7, 32]. Non-insured items, such as fees for the light sedations for a COL procedure, are set by private providers, which tend to include profits and higher management salaries [278]. For example, propofol and midazolam are short-acting sedations that are commonly used for a COL procedure. The cost of these sedations was said to be up to KRW 5,000 per ampule but the price charged to service users ranged from KRW 75,000 to 250,000 per COL procedure in Korea [31, 279, 280]. Costs associated with CRC

diagnosis in the NHI are considered in the model (CRC cohort, see Appendix Tables A5.7.1-A5.7.2).

Approximately 38% of total cancer treatment was paid for by cancer patients, while 61.8% was being paid for by NHI in Korea (see Appendix Table A5.8) [281].

Reported CRC stages were recorded using partially adopted Surveillance, Epidemiology and End Results Programme (SEER) in the CRCS. Given the lack of clear reporting of the CRC stages due to the partial adoption of SEER (1, 2, 7 and 9) in the CRCS, SEER 1 was assumed to be equivalent to Dukes' A CRC. It was assumed that SEER 2 regional CRC was equivalent to the sum of Dukes' B and C, SEER 7 distant CRC to stage D CRC in the model (see Appendix Table A5.9). The resource use for CRC treatment was possibly under-estimated because the SEER 9 CRC (reported as 'unknown or unspecified') was not included in the resource estimation.

Primary chemotherapy agents are recommended by clinicians and reimbursed by NHI, and designated guidelines for post-operative adjuvant chemotherapy must be followed for the full reimbursement. As for secondary chemotherapy agents, the timing, interval and indications of chemotherapy must be followed for the NHIS reimbursement (see Appendix Tables A5.10-A5.11) [282, 283]. CRC chemotherapy is recommended for CRC stages II-III, however, a recent survey revealed that 67.5% of hospitals had delivered chemotherapy for those with CRC stage I which may result in the additional OOP for the service users [50].

Radiotherapy is recommended as part of CRC treatment (see Appendix Table A5.12). The common adverse events of CRC treatments are vomiting and pain.

The resource associated with the use of anti-emetics and pain management was considered in the model [50].

Cancer treatment costs were said to be highest in the initial phase and in the terminal stage of disease [283]. Direct medical costs were included in the model as almost all health care service utilisation is subject to co-payment including CRC treatments. Unrelated future medical costs incurred from clinical trials and productivity costs incurred from morbidity and mortality were excluded in the analysis [83]. Average annual co-payment by cancer patients has been reported to be higher than that of the general population with non-cancer chronic conditions such as hypertension or diabetes (see Appendix Table A5.8) [284].

The follow-up costs of CRC are defined as the costs of follow-up visits, outpatient clinic visits for CRC and non-CRC. CRC treatment costs were possibly over- or under-estimated due to the claims data being aggregated. CRC patients' non-CRC related claims were included in the CRC treatment period of 12 months. For example, CRC patient's specialist clinic visits for hypertension were included in the follow-up cost. Approximately 60% of CRC patients had existing chronic conditions such as hypertension, diabetes, and hyperlipidaemia leading to additional health service usage, therefore it appeared to be reasonable to have OOPs towards direct medical costs included in the base-case analysis because the average age of CRC diagnosis is 60 years and older in Korea [283].

The initiation and completion of active treatment of CRC took place within the first 6 months of CRC diagnosis [50]. Therefore, CRC treatment costs were estimated for the first 6 months of active treatment following a CRC diagnosis, and the 7th-

12th months from CRC diagnosis were defined as the follow-up period after active treatment.

Estimated mean costs of diagnosis, treatment and follow-up costs of CRC in the NHI are presented in Table 5.6. The number of people in the cohort moving from one health state to another are calculated using the transition probabilities, and the number in each state is multiplied with the sum of relevant costs e.g. COL surveillance, diagnosis, treatment and follow-up costs of CRC using costs as presented in Table 5.6. It was assumed that all stages of CRCs were treated the same regardless of the methods of CRC being detected, however, symptomatic presentations of CRC are anticipated to have a high proportion of Dukes C and stage D CRC compared to the COL surveillance detected CRC [51, 99].

Table 5.6 Estimated mean cost of diagnosis, treatment and follow-up of CRC

(Unit: KRW; KRW 1,000=GBP 0.56)

Description	Base-case	SE	Lower	Upper	Distribution for PSA [271]
Colonoscopy	74240	93471.46	58947	185040	Gamma
Pathology for adenoma	56053	60575.24	30,390	112,106	Gamma
Pathology for cancer	165811	263982.21	59123	415235	Gamma
DA diagnosis	856125	259160.12	1700520	2050127	Gamma
DA treatment	2896545	2952037.81	599852	4582151	Gamma
DA follow-up	1248482	1299701.26	401544	2154841	Gamma
DB diagnosis	985615	1046022.98	545460	1956545	Gamma
DB treatment	3365951	3851891.77	788952	5985154	Gamma
DB follow-up	1589554	1408229.8	459892	2359594	Gamma
DC diagnosis	985615	1046022.98	545460	1956545	Gamma
DC treatment	3365951	3851891.77	788952	5985154	Gamma
DC follow-up	1589554	1408229.8	459892	2359594	Gamma
DD diagnosis	1235945	1309634.54	698915	2465612	Gamma
DD treatment	4856959	4223921.42	894545	6592615	Gamma
DD follow-up	1845465	3318769.46	348595	4825615	Gamma

CRC colorectal cancer; **CRC cohort** short-term analysis of the CRCS in NHS, Korea, 2009-2012 (Chapter 2); **DA** Dukes' A CRC; **DB** Dukes' B CRC; **DC** Dukes' C CRC; **DD** stage D CRC; **GBP** Great British pound; **KRW** Korean Won; **PSA** probabilistic sensitivity analysis; **SE** standard error; **SA** sensitivity analysis

5.2.4 Results

The natural history of adenoma-carcinoma (No COL surveillance strategy) was validated against the life expectancy amongst the Korean population (see Appendix Table A5.13 and Appendix Figure A5.1) [2]. It was not feasible to validate the COL surveillance outcomes estimated by the model against Korean trial data because the CRC cohort data is the first of their kind from a population level in Korea. It would have been ideal if the predicted outcomes from a natural history of adenoma-carcinoma (absence of COL surveillance) compared to observed data from pre-screening era in Korea, however, there is no data representing the absence of COL surveillance in Korea. Information from the short-term analysis of the CRC cohort, 2009-2012 (Chapter 2) including fuller information in light of NC pathway can be improved further by utilising longer-term CRCS data in the NHI. Such findings from the longer-term CRCS data will provide basis for the validation of future CUA.

Base-case results

Table 5.7.1 presents the results of the deterministic base-case analysis. Strategies are presented by increasing cost in order to identify dominated strategies (more costly and less effective) using incremental analysis given the multiple comparators. The results presented in Table 5.7.1 suggest that the 0LR3HR strategy is expected to be most cost-effective strategy, given a cost-effectiveness threshold of KRW 30,000,000 per QALY gained with the incremental cost-effectiveness ratio of KRW 29,538 per QALY gained compared to No_COL.

Table 5.7.1 Deterministic base-case analysis results

(Unit: KRW; KRW 1,000=GBP 0.56)

Strategy	Cost	QALY	Inc Cost	Inc QALY	ICER
No_COL	4489	13.486132			
0LR3HR	7395	13.584507	2906	0.09838	29,538
0LR2HR	7580	13.584454	185	-0.00005	Dominated by 0LR3HR
0LR1HR	7775	13.584427	195	-0.00003	Dominated by 0LR3HR
5LR3HR	48710	13.475073	40935	-0.10935	Dominated by 0LR3HR
5LR2HR	48827	13.474953	117	-0.00012	Dominated by 0LR3HR
5LR1HR	48969	13.474950	142	0.00000	Dominated by 0LR3HR
3LR3HR	54495	13.471932	5526	-0.00302	Dominated by 0LR3HR
3LR1HR	54656	13.471866	160	-0.00007	Dominated by 0LR3HR
1LR1HR	59253	13.471011	4598	-0.00085	Dominated by 0LR3HR

COL colonoscopy; **GBP** Great British pound; **HR** high-risk; **ICER** incremental cost-effectiveness ratio; **Inc** incremental; **KRW** Korean Won; **LR** low-risk; **No_COL** no COL surveillance; **QALY** quality-adjusted life years

The breakdown of costs and QALYs indicates that the benefit of an intervention is driven by early detection of CRC as presented in Table 5.7.2. The 0LR3HR strategy resulted in 14 fewer CRC-related deaths compared to the No_COL strategy. Compared with the No_COL strategy, the 0LR3HR strategy resulted in 5 fewer cancers and 9 less symptomatic CRC per 1000 patients entering COL surveillance. As the intensity of COL surveillance increased, the cost of surveillance also increased, with an average lifetime per patient cost of KRW 3489 for the 0LR3HR strategy (least intensive) compared to the 1LR1HR strategy KRW 59,174 (most intensive, Table 5.7.2). Notably, the 1LR1HR strategy, which resulted in fewer symptomatic CRC and CRC-related deaths than the 0LR3HR strategy, also resulted in fewer QALYs possibly due to disutility from COL.

Table 5.7.2 Breakdown of costs and QALYs

(Unit: KRW; KRW 1,000=GBP 0.56)

Strategy	Total number of symptomatic CRC	Total CRC deaths	Cost of COL surveillance per person, KRW	Treatment cost of symptomatic CRC per person, KRW	QALYs: symptomatic CRC per person
No_COL	150.68	397.49	0	17511837	0.0284
0LR3HR	141.57	373.43	3489	15216767	0.0267
0LR2HR	141.55	373.35	3674	15214061	0.0267
0LR1HR	141.57	373.26	3870	15210407	0.0267
5LR3HR	16.52	7.83	48305	803199	0.0051
5LR2HR	16.08	7.61	48425	781931	0.0050
5LR1HR	16.08	7.61	48568	781837	0.0050
3LR1HR	3.63	0.85	54430	158181	0.0012
1LR1HR	0.17	0.03	59174	7143	0.0001
3LR3HR	3.83	0.92	54264	167168	0.0013

COL colonoscopy; **CRC** colorectal cancer; **GBP** Great British pound; **HR** high-risk; **Inc** incremental; **KRW** Korean Won; **LR** low-risk; **No_COL** no COL surveillance; **QALY** quality-adjusted life years

Sensitivity analysis

A series of sensitivity analyses was undertaken to explore the potential impact on the results by varying individual parameters as presented in Table 5.8. When the reimbursement rate of COL was varied using the costs from UK, Singapore and the US (KRW 16,500-5,680,000) [32, 285] the 0LR3HR strategy appears to be the most cost-effective strategy compared to the No_COL given a cost-effectiveness threshold of KRW 30,000,000 per QALY gained. Full results of sensitivity analyses are in Appendix Table A5.14. Another driver of the uncertainty is the structure of model. When the CRC-free health state was further divided into LR (0.217), HR (0.208) and CRC-free states (age-dependent) the No COL strategy was dominant (see Table 5.8) [190, 284]. However, this might not be the case in a Korean context where reported mean EQ-5D value of 0.93 among Koreans with cancer compared to 0.98 in those without cancer [284]

Table 5.8 Summary results of sensitivity analyses

(Unit: KRW; KRW 1,000=GBP 0.56)

Description/ parameters	Base-case	Sensitivity Analysis	CE strategy	ICER (compared to)	Reference
Discount rates for future costs and benefits					
	5%	0%	0LR3HR	4,290 (No_COL)	HIRA (2011) [83]
	5%	3.5%	0LR3HR	18,935 (No_COL)	HIRA (2011) [83]
	5%	7%	0LR3HR	49,346 (No_COL)	HIRA (2011) [83]
Alternate transition probabilities (quarterly)- Adenoma recurrence post-polypectomy					
Probability of adenoma recurrence at year 1 pp_LR	0.0024	0.0084	0LR3HR	28,419 (No_COL)	Assumption
Probability of adenoma recurrence at year 1 pp_HR	0.0012	0.0037	0LR3HR	29,585 (No_COL)	Assumption
*Probability of adenoma recurrence (LR) at year 1 pp_LR	0.0024	0.026	5LR3HR	3,718,969 (0LR3HR)	Whyte (2012) [96]
*Probability of adenoma recurrence (LR) at year 1 pp_HR	0.0012	0.0026	0LR3HR	29,999 (No_COL)	Whyte (2012) [96]
Risk stratification - number of adenomas					
	4≤HR	7≤HR	0LR3HR	25,386 (No_COL)	Assumption
Proportion of LR:HR in the model					
	87.5:12.5	0:100	0LR3HR	237,256 (No_COL)	Assumption
	87.5:12.5	50:50	0LR3HR	29,538 (No_COL)	Assumption
Alternative HSUVs					
Dukes' A CRC	0.2078	0.1654	0LR3HR	37,753 (No_COL)	Assumption Kim (2011) [286]
Dukes' B CRC	0.2133	0.1654			
Dukes' C CRC	0.2043	0.1671			
Stage D CRC	0.1830	0.1667			
Dukes' A CRC	0.2078	0.1850	0LR3HR	81,070 (No_COL)	Ness (1999) [174]
Dukes' B CRC	0.2133	0.1675			
Dukes' C CRC	0.2043	0.1250			
Stage D CRC	0.1830	0.0625			
Cancer-free, LR and HR HSUVs	Age	LR 0.217 HR 0.208 AF Age	0LR3HR	1,142,623 (No_COL)	Wong (2013b) [190]
COL reimbursement in KRW					
	74,240	5,680,000	0LR3HR	1,603,549 (No_COL)	Ahn (2015) [285]
	74,240	165,000	0LR3HR	476,300 (No_COL)	Ahn (2015) [285]
COL surveillance start and ceasing age (years)					
	50-80	50-75	0LR3HR	30,451 (No_COL)	Sohn (2015) [64]
	50-80	*40-80	0LR3HR	17,396 (No_COL)	Assumption
*Risk-based strategies compared to No_COL			0LR3HR	29,538 (No_COL)	
*Non-risk-based strategies compared to No_COL			No_COL	Dominant	

AF adenoma-free; Age age-dependent; CE cost-effective; COL colonoscopy; CRC colorectal cancer; GBP Great British pound; HR high-risk; HSUVs health state utility values; ICER incremental cost-effectiveness ratio; KRW Korean Won; LR low-risk; No_COL no colonoscopic surveillance; pp_LR post-polypectomy of LR adenomas; pp_HR post-polypectomy of HR adenomas; ***additional analyses added**

Results from a PSA indicates that the 0LR3R strategy is expected to be cost-effective with the incremental cost-effectiveness ratio (ICER) of 33,936 per QALY gained compared to the No_COL strategy (see Table 5.9).

Table 5.9 Probabilistic base-case results

(Unit: KRW; KRW 1,000=GBP 0.56)

Strategy	Total cost	Total QALY	Inc Cost	Inc QALY	ICER
No_COL	4136	13.48496			
0LR3HR	7094	13.57211	2958	0.0872	33,936
0LR2HR	7277	13.57202	183	-0.0001	Dominated by 0LR3HR
0LR1HR	7470	13.57194	193	-0.0001	Dominated by 0LR3HR
3LR1HR	54554	13.47195	47084	-0.1000	Dominated by 0LR3HR
5LR3HR	48505	13.47539	-6049	0.0034	Dominated by 0LR3HR
5LR2HR	48668	13.47530	163	-0.0001	Dominated by 0LR3HR
5LR1HR	48780	13.47529	111	0.0000	Dominated by 0LR3HR
3LR3HR	54379	13.47201	5600	-0.0033	Dominated by 0LR3HR
1LR1HR	59053	13.47100	4674	-0.0010	Dominated by 0LR3HR

No_COL no colonoscopic surveillance ; **GBP** Great British pound; **HR** high-risk; **ICER** incremental cost-effectiveness ratio; **Inc** incremental; **KRW** Korean Won; **LR** low-risk; **No_COL** no COL surveillance; **QALY** quality-adjusted life years

The cost-effectiveness plane is presented in Figure 5.3.

Figure 5.3 Cost-effectiveness plane compared to No_COL

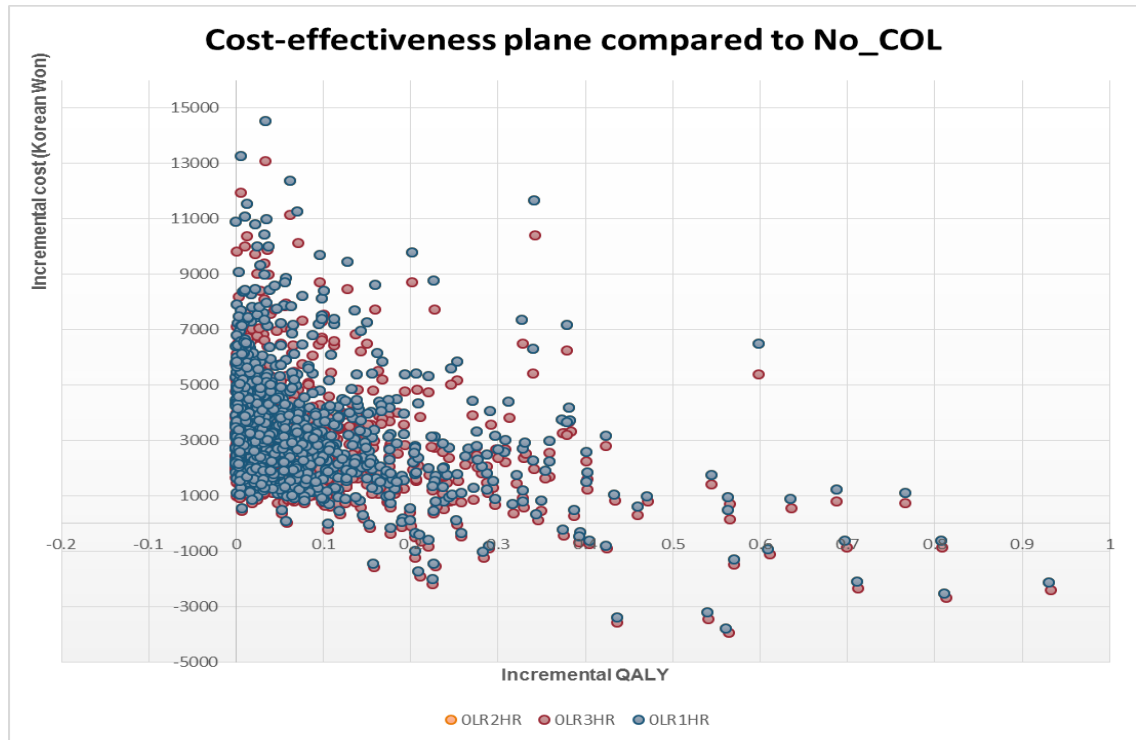

No_COL no colonoscopic surveillance; **HR** high risk; **LR** low risk; **QALY** quality-adjusted life year

There is 98.1% probability that the 0LR3HR strategy is expected to be most cost-effective at the threshold of KRW 30,000,000 per QALY gained, and 1.8% probability for the No_COL strategy. The results remain constant with the varying value of the WTP threshold from KRW 12,000,000 to KRW 32,000,000 (personal communication in confidence and the person wishes to remain anonymous) [287]. Cost-effectiveness acceptability curves (CEAC) are presented in Figure 5.4.

Figure 5.4. Cost-effectiveness acceptability curve

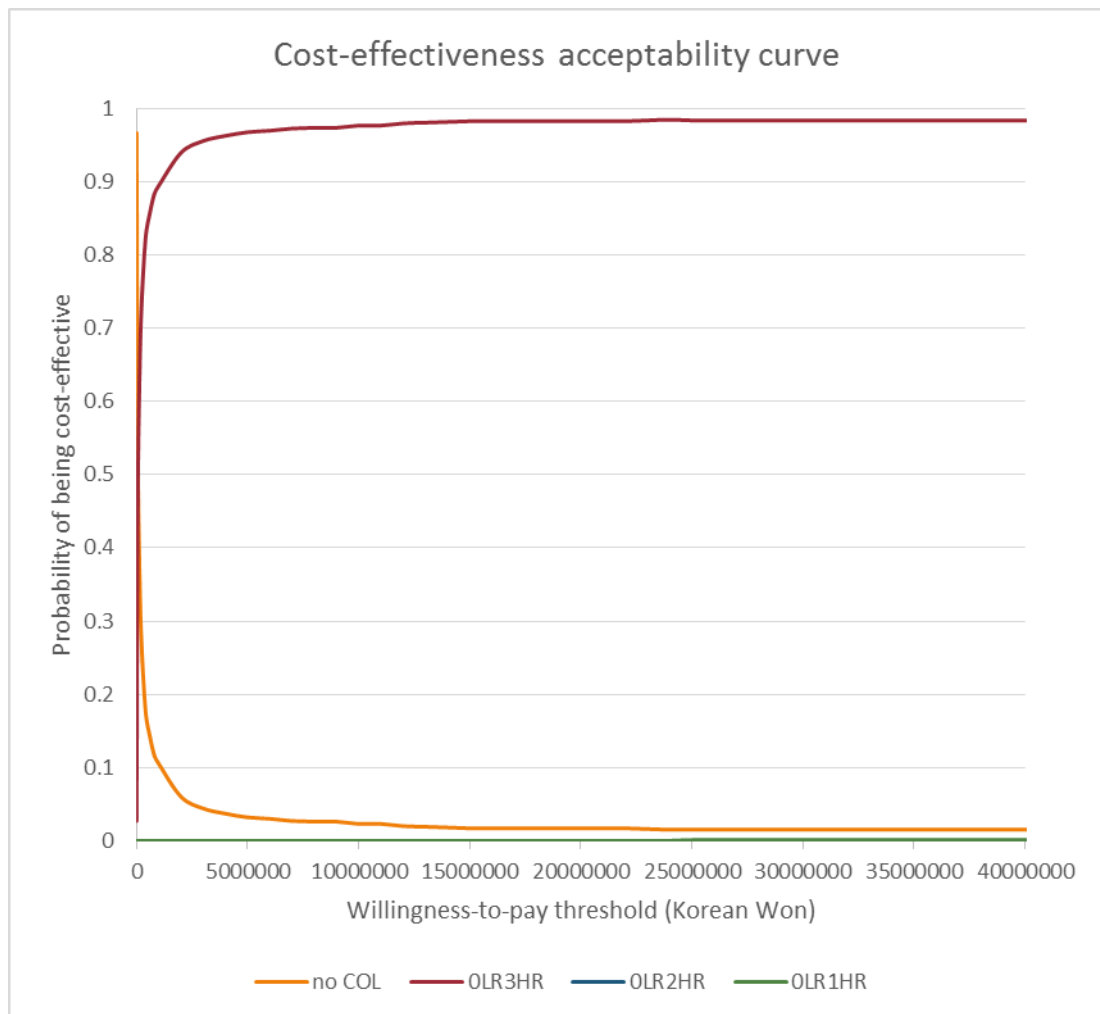

5.2.5 Discussions and conclusion

COL surveillance was reported to be cost-effective when offered to all groups in the National Health Service UK differentiated with intervals based on the risk status of individuals by offering COL surveillance to those in the LR group at 5 year intervals, for those in the intermediate risk at 3 year intervals and those in the HR at 1 year intervals [99], while COL surveillance was said to be most cost-effective among the HR group from the long-term payer perspective in the US settings [76]. As the intensity of COL surveillance increased, the incidence of

symptomatic CRC and CRC-related death decreased (Table 5.7.1-5.7.2) that was similar to the reported results from Saini (2010) [76]. The 0LR3HR strategy resulted in 14 fewer CRC-related deaths compared to the No_COL strategy. Compared with the No_COL strategy, the 0LR3HR strategy resulted in 5 fewer CRC-related deaths and 9 less symptomatic CRC per 1000 patients entering COL surveillance. As the intensity of COL surveillance increased, the cost of surveillance also increased, with an average lifetime per patient cost of KRW 3489 for the 0LR3HR strategy (least intensive) compared to the 1LR1HR strategy KRW 59,174 (most intensive, Table 5.7.2). Notably, the 1LR1HR strategy, which resulted in fewer symptomatic CRC and CRC-related deaths than the 0LR3HR strategy, also resulted in fewer QALYs possibly due to disutility from COL.

COL surveillance offered to those with known HR remained cost-effective in the CRCS, NHI Korea. It is not directly comparable between the model results of this CUA and other reported studies mainly because of different risk stratifications being used in each study, different starting age of intervention, costs of intervention, different clinical practice, WTP for a QALY gained. Nonetheless, the direction of travel of evidence indicates that COL surveillance to selected people with certain characters e.g. HR to be cost-effective.

Adapting or adopting existing cost-effective guidance from other settings to the NHI could not be easily transferred to the Korean NHI setting. This is because of the obvious differences in epidemiology, differences in the structure and delivery of health service, willingness-to-pay of payers, as well as the preferences of individuals and the general public [288, 289].

Despite the widespread use of COL as a follow-up of CRCS, there is no structured management for those who require follow-up COL in the CRCS.

Results of cost-utility analysis indicate that the 0LR3HR strategy is likely to be the most cost-effective strategy for COL surveillance in the prevention and early detection of CRC in the current CRCS, NHI in Korea.

The main strength of this economic analysis is that the model parameters were derived and generated where possible from the short-term analysis of the CRC cohort as presented in Chapter 2. Plausible assumptions were used, and a range of sensitivity analyses was undertaken in order to explore uncertainties in the model by using the most up-to-date evidence where possible. This economic analysis demonstrated the feasibility of providing robust cost-effective evidence by utilising CRCS data that is meaningful and reliable in the Korean context.

However, the modelled stepwise and mutually exclusive health states represent a simplified version of the real world. A critical appraisal of this cost-effectiveness analysis is presented in Appendix Table A5.15.

Several model parameters related to transition probabilities from adenoma health states to CRC and probabilities of transiting through the pre-clinical cancer states remain largely unknown [39] and such evidence cannot be empirically observed as the CRCS has been widely offered in mass and/or opportunistic screenings in many countries [75]. Probable ranges for unknown parameters were derived from the existing literature and a wide uniform distribution was assigned to each parameter in order to carry out Monte Carlo sampling and all unknown parameters were simultaneously sampled and propagated through the model over 50,000 iterations to generate multiple sets of parameters [96]. The definitions of HR or LR in the risk stratification of adenomas differ between reported studies, registries or guidelines. This may have an impact on the adenoma developed into carcinoma in the economic model. When HR was

assumed to be those with 7 or more adenomas the 0LR3HR remained the most cost effective consistent with the base-case result. Clear definitions of LR and HR in the adenoma risk stratification for COL surveillance and CRCS should be a priority for CRCS in Korea.

There are limitations in this analysis. The assumptions used in the model structure was not fully explored in the sensitivity analysis. This is because of the limited evidence around the natural history of adenoma-carcinoma, thus the stepwise progression of the disease was a reasonable assumption in the cohort simulation. As with many countries, the true baseline of index COL among the Korean population is unknown as the population is exposed to COLs through CRCS and various opportunistic screenings in different health care institutions over decades. A complete and detailed baseline index COL would have been key to understanding the natural history of the adenoma-carcinoma sequence, furthermore individuals with different characteristics and behaviours associated with the CRC incidence would provide information for the risk stratification for COL surveillance.

Currently, there is no formally structured COL surveillance in the CRCS NHI Korea, and COL surveillance. In the model, the 'COL surveillance' referred to as no formal structured COL surveillance in order to incorporate the COL surveillance that has been offered irregularly with intervals and frequencies being determined mainly by clinical judgement. Ideally, the absence of COL surveillance as one of modelled strategies would have provided greater insights into the potential costs and relevant outcomes of COL surveillance. Considering the opportunistic screening has been offered to Koreans before the formal KCCR being set up in the 80s there is no data for the absence of COL surveillance in

Korea. The estimated recurrence rates for adenoma post-polypectomy were limited due to the limited date information of subsequent COLs in the CRC cohort. It is particularly problematic when the distinction could not be made between recurrent and missed adenomas in the CRC cohort due to the lack of structured management of follow-up COLs and the current reporting of COL follow-up in the CRCS. However, the base-case results were not sensitive to the alternative recurrence rates of adenomas post-polypectomy (see Table 5.8).

The different CRC staging used by practitioners and governmental agencies adds uncertainties to the CRC cohort and the economic model. There should be a consensus on what should be used when CRC disease stages are reported to NHI to improve the reliability of CRC and NHI data for future studies.

The risk stratifications of LR and HR utilising the CRC cohort may lead to differences in the estimation of adenoma recurrence post-polypectomy compared to the Korean clinical guidelines. The alignment of current CRCS reporting and the risk stratification from clinical guidelines will improve the future analyses of uncertainties around adenoma recurrence post-polypectomy. The modelled CRC disease states are simplified, and this requires further consideration as the costs and benefits of CRC treatments may be under- or over-estimated. HSUVs derived directly from CRC and adenoma among Koreans could be used to strengthen future economic analyses of CRC.

This economic analysis considers COL surveillance as part of CRCS. It does not consider the potential impact of opportunistic screening among Koreans simply because there is no reported evidence related to those who 'cross-over' between CRCS and opportunistic screening.

In addition, the CRC cohort includes the period between 2009 and 2012. Due to the limited information available from the short-term CRC cohort the growth of missed adenomas into carcinomas and the location of adenomas were not considered in the model. Due to the short-term nature of these data the location of adenomas and the movements between the CRC disease states are derived from an alternative existing study [96]. A CRC cohort with a longer-term follow-up will provide further evidence of the adenoma-carcinoma sequence and the movements between the CRC disease states, this will be crucial to improving the robustness of the results of future economic evaluations.

In conclusion, a risk-based 0LR3HR strategy is considered most cost-effective for people with confirmed adenomas in the prevention and early detection of CRC in the CRCS, NHI in Korea. A full pathway modelling of CRCS linking the existing CRCS and COL surveillance utilising CRCS data would provide further insights and completeness of the costs and benefits of CRCS in the NHI [177].

6 DISCUSSIONS AND CONCLUSION

6.1 Introduction

The focus of this thesis is to identify the most cost-effective COL surveillance strategy among individuals with confirmed adenomas for the prevention and early detection of CRC as part of CRCS in the NHI, Korea.

The specific objectives of this thesis are as follows:

- 1) Identification of resources used in CRCS and CRC treatment and mapping of the current clinical practice and CRCS pathways in the prevention and early detection of CRC. A unique opportunity arose to form a research collaboration with Dr Heeyoung Lee at Seoul National University Bundang Hospital, Korea which led to the establishment of a CRC cohort by utilising NHI reimbursement data to provide information for economic evaluation and to map out current practices in CRCS.
- 2) Review of the relevant cost-effectiveness evidence of COL surveillance in people with adenomas – achieved by conducting a literature review of published cost-effectiveness evidence in the prevention and early detection of CRC. The review was also extended to search and identify relevant evidence in a Korean context.
- 3) Identification of HSUVs relevant to CRCS and CRC in order to populate economic model(s) – achieved by conducting a systematic review of HSUVs for economic evaluation of CRC. This study assesses their advantages and disadvantages with respect to valuation methods used and CRC clinical pathways.

4) Identification of cost-effective COL surveillance strategies for individuals with confirmed adenomas in the prevention and early detection of CRC in the CRCS, NHI – achieved by conducting a cost-utility analysis by utilising findings from 1) to 3).

This PhD thesis consists of a series of research papers which are either published and/or submitted or ready to be submitted to peer-reviewed journals for publication. The presentation of the chapters and relevant papers reflect the logical order of the research questions. Each of these papers includes a discussion section specific to the findings presented in that paper.

The following sections 6.2 and 6.3 present the overall findings and the limitations of this thesis. The next section (6.4) then describes the contributions made to current knowledge concerning the cost effectiveness of risk-based COL surveillance strategies in the CRCS, NHI in Korea. The implications for policy and areas for future research are presented in sections 6.5 and 6.6.

6.2 Findings of the thesis

6.2.1 Identification of common pathways in the CRCS and relevant costs by utilising the short-term analysis of CRC cohort, 2009-2012

Any economic evaluation based solely on the published literature could be easily detached from current practice and reality, and as a result the findings could be misleading. The collaboration formed with a Korean researcher led to the development and analysis of a CRC cohort (2009-2012) to ensure that this thesis

reflected Korean practice. Therefore, the results from this thesis are meaningful to the decision makers in a Korean context. Four common pathways (NC, CRCS only, CRCS combined with HCSU and HCSU only) were identified in the CRCS, indicating varying clinical practice that is inconsistent with the CRCS reimbursement policy in the NHI. Resources used in the CRCS and the treatment of CRC were identified for the economic evaluation of CRC. This short-term analysis of CRCS is the first study to map out common pathways in the CRCS by utilising the NHI data at a population level in Korea. This analysis exemplifies the potential advantages of utilising NHI data in population health research which could provide invaluable information on the current practice and resources used in the CRCS and NCSPs, NHI.

6.2.2 Review of cost-effectiveness of COL surveillance and CRCS

The cost-effectiveness of CRCS has long been studied in many countries, however the cost-effectiveness of COL surveillance remains under-studied [100]. Results from this review indicate that the chosen comparators and intervention did not fully reflect current practice and uncertainties associated with parameter inputs and structure were not fully addressed. Modelled downstream effects of COL surveillance or CRCS were limited.

A further review of Korean evidence, presented in Appendix Tables A5.1.1-5.1.2, indicated that there is a paucity of cost-effectiveness evidence regarding the intensity of COL surveillance in the CRCS, NHI.

6.2.3 Systematic review of HSUVs for economic evaluation of CRC

The systematic review of HSUVs for economic evaluation of CRC revealed striking variations in CRC-related HSUVs, even for similar health states [259]. Such variations directly increase the uncertainty regarding cost-effectiveness. This review also found that there were few methodologically robust HSUVs with the health states of interest that can be directly used in the economic evaluation of CRC. Thus, there is considerable scope for new HSUVs to be developed which improve on those currently available to produce better estimates of QALYs and cost-effectiveness in order to inform the decision making and resource allocation in the CRCS. In addition, the review highlighted gaps in the evidence and opportunities for informative research into the most appropriate method to measure and value CRC-related health states.

A further review of evidence revealed the lack of HSUVs that were robust enough for the economic evaluation of CRC in the Korean context as presented in Appendix Tables A5.6.1-5.6.4.

6.2.4 Identification of cost-effective strategies for COL surveillance in the CRCS, NHI

A cost-utility analysis was undertaken in line with the HIRA's current guideline for economic evaluation for the NHI submission [83]. Parameter inputs were derived from the CRC cohort analysis where possible. Gaps in the CRC cohort were complemented by the most up-to-date and most relevant published evidence [96]. Plausible assumptions were explored through a series of sensitivity analyses to address uncertainties around the cost-effectiveness estimates. Results from the

economic evaluation indicated that the risk-based 0LR3HR strategy would be the most cost-effective strategy for COL surveillance in the CRCS, NHI.

6.3 Overall limitations

6.3.1 Short-term analysis of CRCS using the NHI reimbursement data

The short-term analysis of CRCS highlighted the potential of the comprehensive CRCS data for future use of informing the decision making process in the NHI. However, the continuity of data collection can be strengthened by linking reimbursement data with disease registry data.

For the purpose of mapping CRCS pathways it was assumed that pathways were mutually exclusive in the short-term analysis of CRCS, 2009-2012. Four pathways were mapped out using the CRC cohort data: CRCS only, HCSU only, CRCS combined with HCSU and NC. The mapped pathways did not consider additional tests performed after CRC diagnosis or those individuals who dropped out of the CRCS but later returned to CRCS via separate pathways. Therefore, reported diagnostic costs of CRC might have been under-estimated in this analysis. Furthermore, additional resources used and costs associated with the NC group were outside the current CRCS and NHI, thus leading to a possible under-estimation of resources used in the NC pathway.

The reporting of COL results did not include the number of adenomas detected/removed during the follow-up COL in the CRCS, therefore the number of biopsies taken during the follow-up COL was used as a proxy for the number of adenomas in the risk stratification for the cost-effectiveness analysis. The

short-term CRC cohort, 2009-2012, was not comprehensive enough to inform the economic model fully.

A risk-based extrapolation of CRC-free survival post-polypectomy beyond the short-term period of CRC cohort (2009-2012) was not possible due to the limited information on the dates of follow-up COLs linked to their outcomes thus the risk-based (LR or HR) extrapolation was not undertaken.

6.3.2 Potential selection biases in the reviews

Two empirical evidence reviews undertaken as part of this research have potential selection biases because the searches were restricted to publications in English or Korean [100, 259]. Studies or reports published in non-English or non-Korean languages were omitted in the reviews of economic evaluations and of HSUVs in the Korean context.

6.3.3 Cost-effectiveness analysis of COL surveillance, CRCS

Little is known about the natural history of the adenoma-carcinoma sequence and the probability of those in the HR group developing cancer, therefore the probabilities for CRC disease progression were derived from existing evidence [96]. Adenoma recurrence rates post-polypectomy were derived from a short-term CRC cohort analysis, thus there is uncertainty around the modelling of surveillance due to the short-term data, 2009-2012.

The risk stratification of LR and HR groups utilising the CRC cohort data may lead to differences in the estimation of adenoma recurrence post-polypectomy

because of discrepancies between the reporting of COL results in the CRCS and the risk stratifications from Korean clinical guidelines. The location of adenomas associated with the different location of CRC were not considered in the model. This analysis combined data on the natural history of adenoma-carcinoma from Korea and the UK where the prevalence of adenoma and CRC may differ between the two countries.

6.4 Overall contribution of thesis

Despite the limitations discussed in the previous sections, the findings of this thesis highlight the gaps in research concerning cost-effectiveness evidence of COL surveillance for individuals with confirmed adenomas in the prevention and early detection of CRC in the CRCS, NHI in Korea and identified the most cost-effective COL surveillance strategy based on the best available evidence. This thesis has made the following contributions to knowledge concerning the cost-effectiveness of COL surveillance in the prevention and early detection of CRC in Korea:

- 1) This thesis includes the first CRC cohort analysis, 2009-2012 by utilising the comprehensive NHI dataset. This review mapped out common pathways in the CRCS.
- 2) This thesis includes the cost-effectiveness evidence review of CRCS and COL surveillance in the prevention and early detection of CRCS from various settings. A further search of Korean evidence identified gaps in the cost-effectiveness evidence on COL surveillance in CRCS Korea.

3) This thesis includes a systematic review of HSUVs of CRC for economic evaluation. This study reviews CRC-related HSUVs that could be used in economic evaluation and assesses their advantages and disadvantages with respect to valuation methods used and CRC clinical pathways.

4) This thesis contains the first cost-utility analysis of COL surveillance by utilising findings from the short-term analysis of a CRC cohort in CRCS in the NHI, Korea.

6.5 Implications for policy

Policies to increase compliance to FOBT and follow-up tests are required in the current CRCS. Further studies related to incremental costs and benefits of CRCS and follow-up COL are warranted. Policies for the structured follow-up COL post-polypectomy that is linked to the existing CRCS should be developed.

The results of the economic evaluation will be useful in aiding decision making in both policy and clinical settings to promote efficient use of health care resources in the NHI.

The use of cost-effectiveness evidence as one of the tools in resource allocation is currently limited to pharmaceutical products in the NHI, and the expansion of cost-effectiveness evidence can be of great help to promote transparent decision making in clinical practice. The focus of this research was the cost-effectiveness of strategies for COL surveillance of individuals with confirmed adenomas within the CRCS. The approaches taken with the CRC cohort (2009-2012), identified methodological and practical challenges which are also applicable to other NCSPs in the NHI which can inform the decision making process in the NHI.

Over a decade, a great deal of effort has been committed to the CRCS, however, there are no cost-effective COL surveillance strategies for individuals with confirmed adenomas in the current CRCS, but COLs performed as part of the follow-up process have been reimbursed without a ceiling (limit) in cost under the current CRCS reimbursement policy. This thesis indicates that the 0LR3HR strategy based on the risk status of individuals is likely to be the most cost-effective follow-up strategy in the CRCS, NHI. Thus the existing reimbursement decision should be reviewed and amended accordingly. In addition, people who are currently diagnosed with and treated for CRC should to be excluded from the annual CRCS invitation.

HIRA's guidelines for economic evaluation do not indicate a specific cost-effectiveness threshold but the implicit WTP is said to be KRW 30,000,000 per QALY gained (personal communication). A review of the economic evidence submitted for thirteen reimbursement decisions (2005-2009) reported an implicit WTP of about KRW 32,000,000 per QALY gained [290]. The lack of WTP thresholds clearly communicated to stakeholders, often creates myths and mistrust regarding which new costly technologies would or would not be funded in the NHI. Submitted economic evidence to HIRA for the reimbursement decision did not specify the source of HRQoL or HSUVs used in the cost-utility analysis, nor uncertainties associated with HSUVs being addressed in the decision [10] whereas the importance of choosing the most appropriate HSUVs for economic evaluation was highlighted as inappropriate HSUVs would have direct impact on the final decision. Economic evaluation can be used to bring multiple stakeholders together rather than divide them – there are areas which can

improve and promote a better use of economic evidence in the decision making process in the NHI.

The harmonisation of reporting and communication of CRCS findings between governmental bodies, professional bodies and health service providers is crucial to improving the existing data quality in the CRCS and the fuller utilisation of a comprehensive NHI dataset. With the rising demands from service users and a rapidly ageing population, improved transparency in decision making and a better communication with stakeholders about results from robust economic evaluation for reimbursement decisions should be of priority in order to maintain effective working relationship with all stakeholders in the NHI. Consensus around the reporting of CRCS results, a clearly agreed risk stratification of adenomas and CRC disease stages in the current CRCS are of paramount importance as they determine the most appropriate treatment for improving survival.

Although the consensus guideline for CRCS and a regular follow-up of individuals with adenomas are recommended in the Asian Pacific Guideline [59, 60], only Japan and Korea offer CRCS at a national level due to resource constraints in other countries [134]. The approaches taken and the findings of this thesis demonstrate how to utilise data captured in the existing reporting infrastructure that could inform the decision making, mapping current clinical practice, and provide a basis for the economic analyses of other NCSPs in Korea. Methods used in the identification of relevant economic evidence, the HSUVs for economic evaluation of CRC and a *de novo* cost-utility analysis from this thesis could be considered in further comparative policy analyses in other Asian countries where similar trends of CRC are observed. Risk-based COL surveillance may be more

cost-effective than universal COL surveillance in the existing CRCS and this may be generalizable to other Asian countries considering the increasing incidence of CRC in Asia [291]. For example, cost-effectiveness analysis of risk-based COL surveillance strategies could promote evidence-informed decision making where a COL is routinely offered to individuals 40 years and older in Japanese CRCS [134].

Health service fees in the NHI are set by the MoHW, and these have been perceived insufficient to meet the minimum costs of service delivery by service providers [7, 261]. For example, non-insured items such as fees for the light sedations for a COL procedure are 10-25 times higher than their cost [8, 279, 280]. The state-set fee for COL led to wide variations in the price of sedation for COL by private health service providers – there should be an open process of engagement and communication between the state and the health service providers. Economic evaluation has been recently introduced in reimbursement decision making in Korea but the much-needed transition from state-set health service fees to transparent communication of decision making is yet to take place in the CRCS and NHI.

The findings provide invaluable intelligence on the current practice as to CRCS pathways and relevant costs in the CRCS at a population level. With the rapidly increasing health care expenditure, the government attempts to move towards evidence-informed decision-making for health care resource allocation, thus the use of economic evaluation of existing CRCS and NCSPs would provide a better alternative to state-regulated cost control for the NHI in the long term. Together

with the evidence-informed decision making, a genuine consultation with all stakeholders should be embedded in the decision making process such as the decision rules and the process of evidence to recommendations, as opposed to the notification of reimbursement decisions alone [10].

There is a road ahead for the CRCS in the NHI as the current decision making process could be improved by reinforcing and adding the following steps:

1) A risk-based 0LR3HR strategy is expected to be the most cost-effective in COL surveillance, given a cost-effectiveness threshold of KRW 30,000,000 per QALY gained compared to No COL surveillance strategy in the current CRCS, NHI. Therefore, risk-based 0LR3HR COL surveillance should be implemented in the CRCS.

2) A stakeholder consultation that is meaningful and genuine is lacking in the current process of evidence review leading to the reimbursement decision making [83].

3) Clear criteria should be set for the frequency and reimbursement for the COL surveillance that is seamless from CRCS, COL surveillance to HCSU in the NHI. As such the number of unnecessary COLs would be curbed. There should be a mechanism to avoid duplication of payment for repeated COL procedures in the CRCS, NHI.

4) The reporting of COL and CRCS should include much needed information for contributing to the risk stratification of COL surveillance and the CRC disease. The number and size of adenomas detected/removed from COL should be added to the existing reporting of CRCS. Risk stratification and CRC staging information should be based on consensus, complete and comprehensive reporting in CRCS.

5) A separate follow-up programme for the individuals with CRC needs to be considered rather than including them with the general population in the annual invitation of CRCS.

6.6 Areas for further research

The CRC cohort and the cost-effectiveness analysis in this thesis demonstrate the feasibility of utilising existing NHI data for future research. Information from the short-term analysis of the CRC cohort, 2009-2012 can be improved further by utilising longer-term CRCS data in the NHI. A CRC cohort with data for a longer-term period would enable the estimation of CRC-free survival post-polypectomy in the LR and HR groups.

The natural history of adenoma-carcinoma is under-studied and consideration should be given to utilising longer-term CRCS data from NHI as a suitable alternative to provide evidence related to the adenoma-carcinoma sequence and better estimates of resources and costs used in the CRCS.

Methodologically robust HSUVs with health states of CRC and CRCS for cost-utility analysis in a Korean setting should be given priority. There is considerable scope to develop new HSUVs which improve on these currently available and consequently to derive better estimates of QALYs and cost-effectiveness to inform decision-making. The use of existing mapping algorithms to derive HSUVs for the economic evaluation of CRC should be further researched.

A full pathway modelling of CRCS utilising the CRCS data will provide further insights on the wider costs and benefits of CRCS linked to the COL surveillance in the NHI in the future.

6.7 Conclusion

The aim of the thesis was to identify the cost-effective COL surveillance strategy for people with confirmed adenomas in the CRCS, NHI in Korea. In spite of previously published economic evaluation of the CRCS, the importance of a transparent development process of economic analysis for COL surveillance in the context of Korea became apparent. A rare opportunity arose to form a collaboration with a Korean researcher and obtain access to the CRCS data (2009-2012) in the NHI. Therefore, a CRC cohort was constructed to inform the economic model in addition to the identified objectives of the research. A *de novo* cost-utility analysis of COL surveillance was conducted by utilising findings from a CRC cohort analysis and two reviews performed, which were the first of their kind in the economic evaluation in a Korean context. Results from a *de novo* economic analysis indicate that a risk-based 0LR3HR strategy is considered most cost-effective for individuals with adenomas in the COL surveillance in the CRCS NHI.

This thesis demonstrated the process of evidence review and development of cost-effective strategies for the COL surveillance in the context of CRCS, Korea. Transparent and systematic approaches taken in this thesis and its subsequent results provide a basis for further evaluation of existing NCSPs in NHI and other neighbouring countries.

REFERENCES

1. KOSIS. *Population Projections*. 2012 [cited 2015 27 July]; Available from: http://kosis.kr/statHtml/statHtml.do?orgId=101&tblId=DT_1B35001&conn_path=l2&language=en.
2. KONS, *세계와 한국의 인구현황 및 전망*. 2015, Korea Office of National Statistics Korea. p. 1-40.
3. WHO and MOHW, *Health service delivery profile: Republic of Korea*, in *Health service delivery profile*. 2012, WHO.
4. Chun, C., et al., *Republic of Korea - Health Systems Review*, in *Health Systems in Transition* 2009.
5. Jeong, H.S., *Korea's National Health Insurance--lessons from the past three decades*. *Health Affairs (Millwood)*, 2011. **30**(1): p. 136-44.
6. Kwon, S., T. Lee, and C. Kim, *Republic of Korea Health System Review*, in *Health Systems in Transition*, S. Kwon, Editor. 2015, WHO: Manila, Philippines.
7. Kwon, S., *Payment system reform for health care providers in Korea*. *Health Policy Plan*, 2003. **18**(1): p. 84-92.
8. NHIS. *National Health Insurance Service*. 2015; Available from: <http://www.nhis.or.kr/retrieveHomeMain.xx>.
9. Bae, E., *의약품 경제성평가 지침의 주요 내용 Guidelines for Economic Evaluation of Pharmaceuticals in Korea*. *Journal of preventive medicine and public health (예방의학회지)*, 2008. **41**(2): p. 80-83.
10. Son, K. and T. Lee, *Review of pharmaceutical economic evaluation studies in Korea 국내 의약품 경제성평가의 연구 방법과 활용에 대한 고찰* *Journal of Health Technology Assessment*, 2014. **2**(2): p. 83-92.
11. Park, E., *국가 암검진 사업의 평가와 발전방향 제시 Evaluation of organized cancer screening program in Korea*. 2010, National Cancer Center.
12. Kang, I.O., C.Y. Park, and Y. Lee, *Role of healthcare in Korean long-term care insurance*. *J Korean Med Sci*, 2012. **27** *Suppl*: p. S41-6.
13. Cho, B.L. and C.M. Lee, *Current situation of national health screening systems in Korea*. *J Korean Med Assoc*, 2011. **54**(7): p. 666-669.
14. OECD, *Health at a Glance 2013*. 2013: OECD Publishing.
15. National Cancer Center (NCC), *2014 년도 통계로 본 암현황 Cancer Facts & Figures 2014*. 2014.
16. Shim, J.I., et al., *Results of colorectal cancer screening of the national cancer screening program in Korea, 2008*. *Cancer Res Treat*, 2010. **42**(4): p. 191-8.
17. NHIS, *2013 National Health Insurance Statistical Yearbook*, in *National Health Insurance Statistical Yearbook*. 2014b, National Health Insurance Service: Korea.
18. OECD. *OECD Health Statistics 2014*. 2014; Available from: www.oecd.org/health/healthdata.
19. Kang, M.S., et al., *Sustainability of Korean National Health Insurance*. *J Korean Med Sci*, 2012a. **27** *Suppl*: p. S21-4.

20. National Cancer Centre (NCC), *Annual report of cancer statistics in Korea in 2011*. 2013.
21. Park, H.W., et al., *Colorectal Neoplasm in Asymptomatic Average-risk Koreans: The KASID Prospective Multicenter Colonoscopy Survey*. Gut Liver, 2009. **3**(1): p. 35-40.
22. Choi, K.S., et al., *Cost of Colorectal Cancer Care in Korea: A Prospective Group Study with a 2-year Follow-up*. J Korean Soc Coloproctol, 2008. **24**(5): p. 357-366.
23. Lee, S.H., et al., *Korean Guidelines for Colonoscopic Polypectomy*. Intest Res, 2012. **10**(1): p. 110-124.
24. Yang, D., et al., *Korean Guidelines for Post-polypectomy Colonoscopic Surveillance*. Intest Res, 2012. **10**(1): p. 89-109.
25. Lee, W.C. and Y. Kim, *Background and significance of Korean national cancer screening guideline revision*. J Korean Med Assoc, 2015. **58**(4): p. 274-276.
26. Lee, J.Y. and M.W. Jo, *Evidence of a broken healthcare delivery system in Korea: unnecessary hospital outpatient utilization among patients with a single chronic disease without complications*. 2014. **29**(12): p. 1590-6.
27. Kwon, S., *Thirty years of national health insurance in South Korea: lessons for achieving universal health care coverage*. Health Policy and Planning, 2009.
28. Korea Institute of Health Care Management (KIHCM), *Evaluation of service performance of health care institutions*. 1999, KIHCM: Seoul.
29. Samsung. *Samsung Seoul Hospital 건강검진*. [Internet] 27 February 2015; A private hospital website containing details of health screening packages]. Available from: http://www.samsunghospital.com/healthMedical/contents/view.do?VIEW_CODE=A15#.VPC3k2MfXs8.
30. Jo, M.J., *주요 대형병원 기본건강검진 비용 얼마*, in *Dailymedi*. 2011, Dailymedi: Korea.
31. NHIS, *2013 건강검진통계연보 National Health Insurance Statistical Yearbook*, in *National Health Insurance Statistical Yearbook*. 2014a, NHIS: Korea.
32. Han, J., *The current reimbursement system: are we right there? 현 보험급여의 문제점 우리는 충분한 내시경 수가를 받고 있는가?*, in *51st Korean Society of Gastrointestinal Endoscopy Seminar*. 2014: Ilsan, Korea.
33. Winawer, S.J., et al., *Randomized comparison of surveillance intervals after colonoscopic removal of newly diagnosed adenomatous polyps. The National Polyp Study Workgroup*. N Engl J Med, 1993b. **328**(13): p. 901-6.
34. Hamilton, S.R. and L.A. Aaltonen, *World Health Organization Classification of Tumours. Pathology and Genetics of Tumours of the Digestive System*. 2000, Lyon: International Agency for Research on Cancer (IARC) Press.
35. Williams, A.R., B.A. Balasooriya, and D.W. Day, *Polyps and cancer of the large bowel: a necropsy study in Liverpool*. Gut, 1982. **23**(10): p. 835-42.

36. Brenner, H., et al., *Role of colonoscopy and polyp characteristics in colorectal cancer after colonoscopic polyp detection: a population-based case-control study*. Ann Intern Med, 2012. **157**(4): p. 225-32.
37. Olsen, A.H., Lawrence, W., Snook, E., et al *Risk factors and screening techniques in 500 patients with benign and malignant polyps*. Diseases of the Colon & Rectum, 1988. **31**: p. 216-21.
38. Muto, T., Bussey, H. R. J., Morson, B. C., *The evolution of cancer of the colon and rectum*. Cancer, 1975. **36**.
39. Atkin, W.S., et al., *Surveillance guidelines after removal of colorectal adenomatous polyps*. Gut, 2002. **51 Suppl 5**: p. V6-9.
40. Lee, B., et al., *Korean Guidelines for Colorectal Cancer Screening and Polyp Detection*. Intest Res, 2012. **10**(1): p. 67-88.
41. Choe, J.W., et al., *Screening colonoscopy in asymptomatic average-risk Koreans: analysis in relation to age and sex*. J Gastroenterol Hepatol, 2007. **22**(7): p. 1003-8.
42. Byeon, J.S., et al., *Colorectal neoplasm in asymptomatic Asians: a prospective multinational multicenter colonoscopy survey*. Gastrointest Endosc, 2007. **65**(7): p. 1015-22.
43. Chung, S.J., et al., *Prevalence and risk of colorectal adenoma in asymptomatic Koreans aged 40-49 years undergoing screening colonoscopy*. J Gastroenterol Hepatol, 2010. **25**(3): p. 519-25.
44. Kim, H.S., *대장 용종 절제 후 추적 관리 Postpolypectomy colonoscopy surveillance*. 대한소화기내시경학회지 = The Korean journal of gastrointestinal endoscopy, 2009. **39**(5): p. 257-264.
45. Yang, M.H., et al., *The prevalence of colorectal adenomas in asymptomatic Korean men and women*. Cancer Epidemiol Biomarkers Prev, 2014.
46. Lee, A.K., et al., *[Developing the predictive model for the group at high risk for colon cancer]*. J Prev Med Public Health, 2006. **39**(5): p. 438-46.
47. Shin, A., et al., *Risk prediction model for colorectal cancer: National Health Insurance Corporation study, Korea*. PLoS One, 2014. **9**(2): p. e88079.
48. Jung, K.W., et al., *Cancer statistics in Korea: incidence, mortality, survival, and prevalence in 2012*. Cancer Res Treat, 2015. **47**(2): p. 127-41.
49. Byun, J.Y., et al., *Economic burden of colorectal cancer in Korea*. J Prev Med Public Health, 2014. **47**(2): p. 84-93.
50. HIRA, *2011 년 진료분 대장암 적정성 평가 결과 보고서*. 2013a, 건강보험심사평가원.
51. Winawer, S.J., Zauber, A. G., Ho, M. N., et al., *Prevention of Colorectal Cancer by Colonoscopic Polypectomy*. The New England Journal of Medicine, 1993a. **326**: p. 658-662.
52. Kim, Y., et al., *국가건강검진사업 성과평가체계 및 평가지표 개발 연구*. 2013, 서울대학교 산학협력단.
53. Lee, W.C., *건강검진 지침 개발 및 건강검진 제도 개선 (2) Strategies to improve the National Screening Program*, C.U.K. School of Medicine, Editor. 2006.

54. MoHW, *암생존율 상향조정 (Adjusted target mortality in cancer by 2015)*, M.o.H.a. Welfare, Editor. 2011: Seoul.
55. Choi, K., et al., *Cost of Colorectal Cancer Care in Korea: A Prospective Group Study with a 2-year Follow-up*. J Korean Soc Coloproctol, 2008. **24**(5): p. 357-366.
56. MoHW, *2014 년 국가 암검진 사업 안내*. 2014, MOHW.
57. Yoon, Y.S., et al., *Characteristics of Colorectal Cancer Detected at the Health Promotion Center*. J Korean Soc Coloproctol, 2007. **23**(5): p. 321-326.
58. Ransohoff, D.F., C.A. Lang, and H.S. Kuo, *Colonoscopic surveillance after polypectomy: considerations of cost effectiveness*. Ann Intern Med, 1991. **114**(3): p. 177-82.
59. Sung, J., et al., *Asia Pacific Working Group on Colorectal Cancer. Asia-Pacific consensus recommendations for colorectal cancer screening*. Gut, 2008. **57**: p. 1166 - 1176.
60. Sung, J.J., et al., *An updated Asia Pacific Consensus Recommendations on colorectal cancer screening*. Gut, 2015. **64**(1): p. 121-32.
61. Berrington de Gonzalez, A., et al., *Radiation-related cancer risks from CT colonography screening: a risk-benefit analysis*. AJR Am J Roentgenol, 2011. **196**(4): p. 816-23.
62. Brenner, D.J. and M.A. Georgsson, *Mass screening with CT colonography: should the radiation exposure be of concern?* Gastroenterology, 2005. **129**(1): p. 328-37.
63. Halligan, S., et al., *Computed tomographic colonography compared with colonoscopy or barium enema for diagnosis of colorectal cancer in older symptomatic patients: two multicentre randomised trials with economic evaluation (the SIGGAR trials)*. Health Technol Assess, 2015. **19**(54): p. 1-134.
64. Sohn, D.K., et al., *The Korean guideline for colorectal cancer screening*. J Korean Med Assoc, 2015. **58**(5): p. 420-432.
65. Cairns, S.R., et al., *Guidelines for colorectal cancer screening and surveillance in moderate and high risk groups (update from 2002)*. Gut, 2010. **59**(5): p. 666-89.
66. Lieberman, D.A., et al., *Use of colonoscopy to screen asymptomatic adults for colorectal cancer. Veterans Affairs Cooperative Study Group 380*. N Engl J Med, 2000. **343**(3): p. 162-8.
67. Hong, S.N., et al., *Korean guidelines for post-polypectomy colonoscopic surveillance* 폴립절제 후 추적대장내시경검사 가이드라인. Korean J Gastroenterol, 2012. **59**(2): p. 99-117.
68. Choi, E., et al., *Establishment of an efficient management system for advanced outcome of the National Health Screening Policy* 국가건강검진 사업의 성과제고를 위한 수요자 중심의 효율적 관리체계 구축방안. 2009, Korea Institute for Health and Social Affairs (KIHASA): Korea.
69. Chung, S.J., et al., *Five-year risk for advanced colorectal neoplasia after initial colonoscopy according to the baseline risk stratification: a prospective study in 2452 asymptomatic Koreans*. Gut, 2011. **60**(11): p. 1537-43.
70. MoHW and NCC, *Quality guideline of colorectal cancer screening*. 2008.

71. Kim, S.E., et al., [A Korean national survey for colorectal cancer screening and polyp diagnosis methods using web-based survey]. Korean J Gastroenterol, 2012. **60**(1): p. 26-35.
72. Sohn, D.K. and C. Colonoscopy Study Group of the Korean Society of, A survey of colonoscopic surveillance after polypectomy. Ann Coloproctol, 2014. **30**(2): p. 88-92.
73. Bae, E., 의료기술평가를 통한 급여결정의 한계와 극복방안: 기등재 의약품목록 재정비사업에 대한 평가를 주임으로. 보건경제와 정책연구 The Korean Journal of Health Economics and Policy, 2010. **16**(3): p. 163-187.
74. Lee, B.W. and S.Y. Jeong, Korean national recommendation guidelines on screening and surveillance for early detection of colorectal cancer. J Korean Med Assoc, 2002. **45**: p. 981 - 991.
75. Schreuders, E.H., et al., Colorectal cancer screening: a global overview of existing programmes. Gut, 2015. **64**(10): p. 1637-49.
76. Saini, S.D., P. Schoenfeld, and S. Vijan, Surveillance colonoscopy is cost-effective for patients with adenomas who are at high risk of colorectal cancer. Gastroenterology, 2010. **138**(7): p. 2292-9, 2299.e1.
77. Jung, S.Y., D. Sohn, and S.H. Moon, 대장 폴립 진료 권고안, in 2012 Korean Surgical Society Fall Conference. 2012, Korean Surgical Society: Seoul. p. 256-258.
78. Kandaswamy, P.S., et al., S1- An evaluation of pathway modeling to assess cost-effectiveness in guidelines. Otolaryngology -- Head and Neck Surgery, 2010. **143**(1 suppl): p. 10.
79. Tappenden, P., et al., Option appraisal of population-based colorectal cancer screening programmes in England. Gut, 2007. **56**(5): p. 677-84.
80. Cho, B.L., Evaluation of the validity of current national health screening program and plan to improve the system 현행 국가건강검진 프로그램 전반에 대한 타당성 평가 및 제도개선 방안 제시 2012E3302800, KCDC, Editor. 2013.
81. Choi, Y., 국가 건강검진 사업의 경제성 평가 체계 개발에 관한 연구. 2008, Hallim University Korea.
82. Park, S.M., Y.H. Yun, and S. Kwon, Feasible economic strategies to improve screening compliance for colorectal cancer in Korea. World Journal of Gastroenterology, 2005. **11**(11): p. 1587-93.
83. HIRA, 의약품 경제성 평가 지침 약제등재부, Editor. 2011a, HIRA: Korea.
84. Choi, K.S., et al., Increasing uptake of colorectal cancer screening in Korea: a population-based study. BMC Public Health, 2010. **10**: p. 265.
85. MOHW, 2014-2018 건강보험 중기보장성 강화 계획. 2015, Ministry of Health and Welfare: Korea.
86. Latimer, N., NICE DSU Technical Support Document 14: Undertaking survival analysis for economic evaluations alongside clinical trials - extrapolation with patient-level data. 2011, School of Health and Related Research, University of Sheffield: UK.

87. NHIS, 2012 건강검진통계연보 *National Health Screening Statistical Yearbook*, in *National Health Insurance Statistical Yearbook*. 2013: Korea.
88. Szklo, M., *Population-based cohort studies*. *Epidemiol Rev*, 1998. **20**(1): p. 81-90.
89. Jung, M., *National Cancer Screening Programs and evidence-based healthcare policy in South Korea*. *Health Policy*, 2015. **119**(1): p. 26-32.
90. Schulz, K.F., et al., *CONSORT 2010 statement: updated guidelines for reporting parallel group randomised trials*. *Bmj*, 2010. **340**: p. c332.
91. Walters, S., et al., *Comparability of stage data in cancer registries in six countries: lessons from the International Cancer Benchmarking Partnership*. *Int J Cancer*, 2013. **132**(3): p. 676-85.
92. KAMS, *Korean Clinical Practice Guideline for Colon and Rectal Cancer v.1.0 대장암진료권고안 v.1.0*. 2012, Korean Academy of Medical Sciences 대한의학회: Korea.
93. Ruh, J., M. Adamo, and L. Dickie, *SEER Program Coding and Staging Manual 2016: Section V*. 2016, U.S. Department of Health and Human Services National Institutes of Health: Bethesda, MD.
94. Winawer, S.J., et al., *Guidelines for colonoscopy surveillance after polypectomy: a consensus update by the US Multi-Society Task Force on Colorectal Cancer and the American Cancer Society*. *Gastroenterology*, 2006. **130**(6): p. 1872-85.
95. Yamaji, Y., et al., *Right-side shift of metachronous colorectal adenomas after polypectomy*. *Scandinavian Journal of Gastroenterology*, 2007. **42**(12): p. 1466-1472.
96. Whyte, S., *Reappraisal of the options for colorectal cancer screening in England*. *Colorectal Disease*, 2012. **14**(9): p. e547-61.
97. Drummond, M.F., Sculpher, M. J., Torrance, G. W., O'Brien, B. J., Stoddart, G., L, *Methods for the Economic Evaluation of Health Care Programmes*. 3rd ed. 2005, Oxford: Oxford Press.
98. Drummond, M.F. and T.O. Jefferson, *Guidelines for authors and peer reviewers of economic submissions to the BMJ. The BMJ Economic Evaluation Working Party*. *Bmj*, 1996. **313**(7052): p. 275-83.
99. NICE, *Colonoscopic surveillance for prevention of colorectal cancer in people with ulcerative colitis, Crohn's disease or adenomas [CG118]*. 2011, NICE: UK.
100. Jeong, K.E. and J.A. Cairns, *Review of economic evidence in the prevention and early detection of colorectal cancer*. *Health Econ Rev*, 2013. **3**(1): p. 20.
101. Zauber, A.G., *Cost-effectiveness of colonoscopy*. *Gastrointestinal Endoscopy Clinics of North America*, 2010. **20**(4): p. 751-70.
102. Sharp, L., et al., *Cost-effectiveness of population-based screening for colorectal cancer: a comparison of guaiac-based faecal occult blood testing, faecal immunochemical testing and flexible sigmoidoscopy*. *British Journal of Cancer*, 2012. **106**(5): p. 805-16.
103. Pickhardt, P.J., et al., *Small and diminutive polyps detected at screening CT colonography: a decision analysis for referral to colonoscopy*. *AJR. American Journal of Roentgenology*, 2008a. **190**(1): p. 136-44.

104. van Rossum, L.G., et al., *Colorectal cancer screening comparing no screening, immunochemical and guaiac fecal occult blood tests: a cost-effectiveness analysis*. International Journal of Cancer, 2011. **128**(8): p. 1908-17.
105. Pickhardt, P.J., et al., *Cost-effectiveness of colorectal cancer screening with computed tomography colonography: the impact of not reporting diminutive lesions*. Cancer, 2007. **109**(11): p. 2213-21.
106. Theuer, C.P., et al., *Gender and race/ethnicity affect the cost-effectiveness of colorectal cancer screening*. Journal of the National Medical Association, 2006. **98**(1): p. 51-7.
107. McMahon, P.M., et al., *Cost-effectiveness of colorectal cancer screening*. Radiology, 2001. **219**(1): p. 44-50.
108. Parekh, M., A.M. Fendrick, and U. Ladabaum, *As tests evolve and costs of cancer care rise: reappraising stool-based screening for colorectal neoplasia*. Alimentary pharmacology & therapeutics, 2008. **27**(8): p. 697-712.
109. Maciosek, M.V., et al., *Colorectal cancer screening: health impact and cost effectiveness*. American Journal of Preventive Medicine, 2006. **31**(1): p. 80-9.
110. Eddy, D.M., *Screening for colorectal cancer*. American Journal of Physicians, 1990. **113**: p. 373-384.
111. Frazier, A.L., et al., *Cost-effectiveness of screening for colorectal cancer in the general population*. JAMA, 2000. **284**(15): p. 1954-61.
112. Helm, J.F., et al., *Effectiveness and economic impact of screening for colorectal cancer by mass fecal occult blood testing*. American Journal of Gastroenterology, 2000. **95**(11): p. 3250-8.
113. Howard, K., et al., *High participation rates are not necessary for cost-effective colorectal cancer screening*. Journal of Medical Screening, 2005. **12**(2): p. 96-102.
114. Lansdorp-Vogelaar, I., et al., *At what costs will screening with CT colonography be competitive? A cost-effectiveness approach*. International Journal of Cancer, 2009a. **124**(5): p. 1161-8.
115. Lansdorp-Vogelaar, I., et al., *Individualizing colonoscopy screening by sex and race*. Gastrointestinal Endoscopy, 2009b. **70**(1): p. 96-108, 108.e1-24.
116. Macafee, D.A.L., et al., *Population screening for colorectal cancer: the implications of an ageing population*. British Journal of Cancer, 2008. **99**(12): p. 1991-2000.
117. Pickhardt, P.J., et al., *Clinical management of small (6- to 9-mm) polyps detected at screening CT colonography: a cost-effectiveness analysis*. AJR. American Journal of Roentgenology, 2008b. **191**(5): p. 1509-16.
118. Song, K., A.M. Fendrick, and U. Ladabaum, *Fecal DNA testing compared with conventional colorectal cancer screening methods: a decision analysis*. Gastroenterology, 2004. **126**(5): p. 1270-9.
119. Tsoi, K.K.F., et al., *Cost-effectiveness analysis on screening for colorectal neoplasm and management of colorectal cancer in Asia*. Alimentary pharmacology & therapeutics, 2008. **28**(3): p. 353-63.
120. Wilschut, J.A., et al., *Fecal occult blood testing when colonoscopy capacity is limited*. Journal of the National Cancer Institute, 2011b. **103**(23): p. 1741-51.

121. Wong, S.S., A.P. Leong, and T.Y. Leong, *Cost-effectiveness analysis of colorectal cancer screening strategies in Singapore: a dynamic decision analytic approach*. Medinfo, 2004. **MEDINFO. 11**(Pt 1): p. 104-110.
122. Ladabaum, U. and K.A. Phillips, *Colorectal cancer screening differential costs for younger versus older Americans*. American Journal of Preventive Medicine, 2006. **30**(5): p. 378-84.
123. Hassan, C., et al., *Value-of-information analysis to guide future research in colorectal cancer screening*. Radiology, 2009b. **253**(3): p. 745-752.
124. O'Leary, B.A., et al., *Cost-effectiveness of colorectal cancer screening: comparison of community-based flexible sigmoidoscopy with fecal occult blood testing and colonoscopy*. Journal of Gastroenterology & Hepatology, 2004. **19**(1): p. 38-47.
125. Walleser, S., et al., *What is the value of computered tomography colonography in patients screening positive for fecal occult blood? A systematic review and economic evaluation*. Clinical Gastroenterology & Hepatology, 2007. **5**(12): p. 1439-46; quiz 1368.
126. Khandker, R.K., et al., *A decision model and cost-effectiveness analysis of colorectal cancer screening and surveillance guidelines for average-risk adults*. International Journal of Technology Assessment in Health Care, 2000. **16**(3): p. 799-810.
127. Sobhani, I., et al., *Cost-effectiveness of mass screening for colorectal cancer: choice of fecal occult blood test and screening strategy*. Diseases of the Colon & Rectum, 2011. **54**(7): p. 876-86.
128. Sonnenberg, A., F. Delco, and P. Bauerfeind, *Is virtual colonoscopy a cost-effective option to screen for colorectal cancer?* American Journal of Gastroenterology, 1999. **94**(8): p. 2268-74.
129. Sonnenberg, A., F. Delco, and J.M. Inadomi, *Cost-effectiveness of colonoscopy in screening for colorectal cancer*. Annals of Internal Medicine, 2000. **133**(8): p. 573-84.
130. Theuer, C.P., et al., *Racial and ethnic colorectal cancer patterns affect the cost-effectiveness of colorectal cancer screening in the United States*. Gastroenterology, 2001. **120**(4): p. 848-56.
131. Martinez, M.E., Baron, J. A., Lieberman, D. A., Schatzkin, A., Lanza, E., Winawer, S. J., Zauber, A. G., Jiang, R., Ahnen, D. J., Bond, J. H., Church, T., R., Robertson, D. J., Smith-Warner, S. A., Jacobs, E. T., Alberts, D. S., Greenberg, E. R., *A pooled analysis of advanced colorectal neoplasia diagnoses after colonoscopic polypectomy*. Gastroenterology, 2009. **136**(3): p. 832-841.
132. Atkin, W.S., Edwards, R., Kralj-Hans, I., Wooldrage, K., Hart, A.R., Northover, J.M., Parkin, D.M., Wardle, J., Duffy, S.W., Cuzik, J., UK Flexible Sigmoidoscopy Trial Investigators., *Once-only flexible sigmoidoscopy screening in prevention of colorectal cancer: a multicentre randomised controlled trial*. Lancet 2010. **375**(9726): p. 1624-33.
133. Hoff, G., et al., *Risk of colorectal cancer seven years after flexible sigmoidoscopy screening: a randomised controlled trial*. BMJ, 2009. **338**.
134. NCI. *International Cancer Screening Network*. 2015 18 August 2016 [cited 2015 01 January 2016]; Available from: <http://appliedresearch.cancer.gov/icsn/colorectal/screening.html>
135. Granville, J., Kaunelis, D., Mensinkai, S., *How well do search filters perform in identifying economic evaluations in MEDLINE and EMBASE*.

- International Journal of Technology Assessment in Health Care, 2009. **25**(4): p. 522-529.
136. Wagner, J.L., Herdman, R. C., Wadhwa, S., *Cost effectiveness of colorectal cancer screening in the elderly*. Annals of Internal Medicine, 1991. **115**(10): p. 8007-817.
 137. Philips, Z., et al., *Review of guidelines for good practice in decision-analytic modelling in health technology assessment*. Health Technol Assess, 2004. **8**(36): p. iii-iv, ix-xi, 1-158.
 138. Stone, C.A., et al., *Colorectal cancer screening in Australia: an economic evaluation of a potential biennial screening program using faecal occult blood tests*. Australian & New Zealand Journal of Public Health, 2004. **28**(3): p. 273-82.
 139. Hassan, C., et al., *Cost-effectiveness of early one-year colonoscopy surveillance after polypectomy*. Diseases of the Colon & Rectum, 2009a. **52**(5): p. 964-71; discussion 971.
 140. Heitman, S.J., et al., *Cost-effectiveness of computerized tomographic colonography versus colonoscopy for colorectal cancer screening*. CMAJ Canadian Medical Association Journal, 2005. **173**(8): p. 877-81.
 141. Chauvin, P., J.M. Josselin, and D. Heresbach, *Incremental net benefit and acceptability of alternative health policies: A case study of mass screening for colorectal cancer*. European Journal of Health Economics, 2012. **13**(3): p. 237-250.
 142. Dan, Y.Y., et al., *Screening based on risk for colorectal cancer is the most cost-effective approach*. Clinical Gastroenterology & Hepatology, 2012. **10**(3): p. 266-71.e1-6.
 143. Di Bidino, R., et al., *Impact of technology overlapping: a case study on colorectal cancer screening*. Technology & Health Care, 2010. **18**(4-5): p. 303-15.
 144. Hassan, C., P.J. Pickhardt, and D.K. Rex, *A resect and discard strategy would improve cost-effectiveness of colorectal cancer screening*. Clinical Gastroenterology & Hepatology, 2010. **8**(10): p. 865-9, 869.e1-3.
 145. Hassan, C., et al., *Colon cancer prevention in Italy: cost-effectiveness analysis with CT colonography and endoscopy*. Digestive & Liver Disease, 2007. **39**(3): p. 242-50.
 146. Hassan, C., et al., *Cost-effectiveness of capsule endoscopy in screening for colorectal cancer*. Endoscopy, 2008. **40**(5): p. 414-21.
 147. Heresbach, D., et al., *Cost-effectiveness of colorectal cancer screening with computed tomography colonography or fecal blood tests*. European Journal of Gastroenterology & Hepatology, 2010b. **22**(11): p. 1372-9.
 148. Heresbach, D., et al., *Cost-effectiveness of colorectal cancer screening with computed tomography colonography according to a polyp size threshold for polypectomy*. European Journal of Gastroenterology & Hepatology, 2010a. **22**(6): p. 716-23.
 149. Ho, C., et al., *Computed tomographic colonography for colorectal cancer screening in an average risk population: Systematic review and economic evaluation (Structured abstract)*. Ottawa: Canadian Agency for Drugs and Technologies in Health (CADTH), 2008: p. 153.
 150. Ladabaum, U., K. Song, and A.M. Fendrick, *Colorectal neoplasia screening with virtual colonoscopy: when, at what cost, and with what national impact?* Clinical Gastroenterology & Hepatology, 2004. **2**(7): p. 554-63.

151. Lee, D., et al., *Cost Effectiveness of CT Colonography for UK NHS Colorectal Cancer Screening of Asymptomatic Adults Aged 60-69 Years*. Applied Health Economics and Health Policy, 2010. **8**(3): p. 141-54.
152. Lejeune, C., et al., *Cost-effectiveness analysis of fecal occult blood screening for colorectal cancer*. International Journal of Technology Assessment in Health Care, 2004. **20**(4): p. 434-9.
153. Lejeune, C., et al., *Cost-effectiveness of screening for colorectal cancer in France using a guaiac test versus an immunochemical test*. International Journal of Technology Assessment in Health Care, 2010. **26**(1): p. 40-7.
154. Regge, D., et al., *Impact of computer-aided detection on the cost-effectiveness of CT colonography*. Radiology, 2009. **250**(2): p. 488-497.
155. Saini, S.D., H.M. Kim, and P. Schoenfeld, *Incidence of advanced adenomas at surveillance colonoscopy in patients with a personal history of colon adenomas: a meta-analysis and systematic review*. Gastrointest Endosc, 2006. **64**(4): p. 614-26.
156. Telford, J.J., et al., *The cost-effectiveness of screening for colorectal cancer*. CMAJ Canadian Medical Association Journal, 2010. **182**(12): p. 1307-13.
157. Vijan, S., et al., *Which colon cancer screening test? A comparison of costs, effectiveness, and compliance*. American Journal of Medicine, 2001. **111**(8): p. 593-601.
158. Vijan, S., et al., *The cost-effectiveness of CT colonography in screening for colorectal neoplasia*. American Journal of Gastroenterology, 2007. **102**(2): p. 380-90.
159. Wu, G.H.-M., et al., *Cost-effectiveness analysis of colorectal cancer screening with stool DNA testing in intermediate-incidence countries*. BMC Cancer, 2006. **6**: p. 136.
160. Lansdorp-Vogelaar, I., et al., *Stool DNA testing to screen for colorectal cancer in the Medicare population: a cost-effectiveness analysis*. Annals of Internal Medicine, 2010. **153**(6): p. 368-77.
161. Knudsen, A.B., et al., *Cost-effectiveness of computed tomographic colonography screening for colorectal cancer in the medicare population*. Journal of the National Cancer Institute, 2010. **102**(16): p. 1238-52.
162. Loeve, F., et al., *The MISCAN-COLON simulation model for the evaluation of colorectal cancer screening*. Computers & Biomedical Research, 1999. **32**(1): p. 13-33.
163. Loeve, F., et al., *Endoscopic colorectal cancer screening: a cost-saving analysis*. Journal of the National Cancer Institute, 2000. **92**(7): p. 557-63.
164. Ness, R.M., et al., *Cost-utility of one-time colonoscopic screening for colorectal cancer at various ages*. American Journal of Gastroenterology, 2000. **95**(7): p. 1800-11.
165. Subramanian, S., G. Bobashev, and R.J. Morris, *Modeling the cost-effectiveness of colorectal cancer screening: policy guidance based on patient preferences and compliance*. Cancer Epidemiology, Biomarkers & Prevention, 2009. **18**(7): p. 1971-8.
166. Vanness, D.J., et al., *Comparative economic evaluation of data from the ACRIN national CT colonography trial with three cancer intervention and surveillance modeling network microsimulations*. Radiology, 2011. **261**(2): p. 487-498.

167. Wilschut, J.A., et al., *Cost-effectiveness analysis of a quantitative immunochemical test for colorectal cancer screening*. *Gastroenterology*, 2011a. **141**(5): p. 1648-55.e1.
168. Berchi, C., et al., *Cost-effectiveness analysis of two strategies for mass screening for colorectal cancer in France*. *Health Economics*, 2004. **13**(3): p. 227-38.
169. Levine, B., Lieberman, D. A., McFarland, B., Andrews, K. S., Brooks, D., Dash, C., et al., *Screening and surveillance for the early detection of colorectal cancer and adenomatous polyps, 2008: a joint guideline from the American cancer society, the US multi-society task force on colorectal cancer, and the American College of Radiology*. *Gastroenterology* 2008. **134**: p. 1570-95.
170. Park, E.C., et al., *The present and challenges of National Cancer Screening Program 국가 암 조기검진사업의 현황 및 발전 방향*.
한국건강관리협회지= Journal of Korea Association of Health Promotion, 2005. **3**(2): p. 280-287.
171. Heitman, S.J., et al., *Colorectal cancer screening for average-risk North Americans: an economic evaluation*. *PLoS Medicine / Public Library of Science*, 2010. **7**(11): p. e1000370.
172. Chauvin, P., J.-M. Josselin, and D. Heresbach, *The Influence of Waiting Times on Cost-Effectiveness: A Case Study of Colorectal Cancer Mass Screening*. *European Journal of Health Economics*, 2014. **15**(8): p. 801-12.
173. Sonnenberg, A. and F. Delco, *Cost-effectiveness of a single colonoscopy in screening for colorectal cancer*. *Archives of Internal Medicine*, 2002. **162**(2): p. 163-8.
174. Ness, R.M., et al., *Utility valuations for outcome states of colorectal cancer*. *American Journal of Gastroenterology*, 1999a. **94**(6): p. 1650-7.
175. Flanagan, W.M., et al., *Potential impact of population-based colorectal cancer screening in Canada*. *Chronic Diseases in Canada*, 2003. **24**(4): p. 81-8.
176. Chilcott, J., Tappenden, P., Rawdin, A., Johnson, M., Kaltenthaler, E., Paisley, S., Papaioannou, D., Shippam, A., *Avoiding and identifying errors in health technology assessment models: qualitative study and methodological review*. *Health Technology Assessment*, 2010. **14**(25): p. 1-152.
177. Tappenden, P., Brennan, A., Chilcott, J., et al. , *A methodological framework for developing models of whole disease areas to inform resource allocation decisions*. *Value in Health*, 2011. **14**(7): p. A243.
178. Barouni, M., et al., *Markov's modeling for screening strategies for colorectal cancer*. *Asian Pacific Journal of Cancer Prevention*, 2012. **13**(10): p. 5125-5129.
179. Dinh, T., et al., *Health benefits and cost-effectiveness of a hybrid screening strategy for colorectal cancer*. *Clinical Gastroenterology & Hepatology*, 2013. **11**(9): p. 1158-66.
180. Goede, S.L., et al., *Cost-effectiveness of one versus two sample faecal immunochemical testing for colorectal cancer screening*. *Gut*. **62**(5): p. 727-34.

181. Hashimoto, Y., et al., *Cost-effectiveness analysis of CT colonography for colorectal cancer screening program to working age in Japan*. Value in Health Regional Issues, 2014. **3**(1): p. 182-189.
182. Huang, W., et al., *Cost-effectiveness of colorectal cancer screening protocols in urban Chinese populations*. PloS one, 2014. **9**(10): p. e109150.
183. Knudsen, A.B., et al., *Rescreening of persons with a negative colonoscopy result: Results from a microsimulation model*. Annals of Internal Medicine, 2012. **157**(9): p. 611-620.
184. Sekiguchi, M., et al., *Cost-effectiveness of total colonoscopy in screening of colorectal cancer in Japan*. Gastroenterology Research and Practice, 2012(728454).
185. Sharaf, R.N. and U. Ladabaum, *Comparative effectiveness and cost-effectiveness of screening colonoscopy vs. Sigmoidoscopy and alternative strategies*. American Journal of Gastroenterology, 2013. **108**(1): p. 120-132.
186. Van Hees, F., et al., *The appropriateness of more intensive colonoscopy screening than recommended in medicare beneficiaries: A modeling study*. JAMA Internal Medicine, 2014. **174**(10): p. 1568-1576.
187. Wong, C.K.H., et al., *Cost-effectiveness simulation and analysis of colorectal cancer screening in Hong Kong Chinese population: Comparison amongst colonoscopy, guaiac and immunologic fecal occult blood testing*. BMC Cancer, 2015. **15**(1).
188. Barouni, M., H. Ghaderi, and M.K. Shahmoradi, *The economic evaluation of screening for colorectal cancer: Case of Iran*. Clinical Laboratory, 2013. **59**(5-6): p. 667-674.
189. Peasgood, T., S.E. Ward, and J. Brazier, *Health-state utility values in breast cancer*. Expert Rev Pharmacoecon Outcomes Res, 2010. **10**(5): p. 553-66.
190. Wong, C.K., et al., *Clinical correlates of health preference and generic health-related quality of life in patients with colorectal neoplasms*. PLoS ONE [Electronic Resource], 2013b. **8**(3): p. e58341.
191. NICE. *Guide to the methods of technology appraisal*. 2013 [cited 2013 01 December]; Available from: <http://www.nice.org.uk>
192. Hagggar, F.A. and R.P. Boushey, *Colorectal cancer epidemiology: incidence, mortality, survival, and risk factors*. Clin Colon Rectal Surg, 2009. **22**(4): p. 191-7.
193. Sung, J.J., et al., *Increasing incidence of colorectal cancer in Asia: implications for screening*. Lancet Oncol, 2005. **6**(11): p. 871-6.
194. Best, J.H., et al., *Preference values associated with stage III colon cancer and adjuvant chemotherapy*. Quality of Life Research, 2010. **19**(3): p. 391-400.
195. Dominitz, J.A. and D. Provenzale, *Patient preferences and quality of life associated with colorectal cancer screening*. Am J Gastroenterol, 1997. **92**(12): p. 2171-8.
196. Hornbrook, M.C., et al., *Complications among colorectal cancer survivors: SF-6D preference-weighted quality of life scores*. Medical Care, 2011. **49**(3): p. 321-326.
197. Miller, A., et al., *Quality of life and cost effectiveness analysis of therapy for locally recurrent rectal cancer*. Diseases of the Colon and Rectum, 2000. **1695-1703**.

198. Pickard, A.S., et al., *Comparison of FACT- and EQ-5D-based utility scores in cancer*. Value Health, 2012. **15**(2): p. 305-11.
199. Ramsey, S.D., et al., *Quality of life in survivors of colorectal carcinoma*. Cancer, 2000. **88**(6): p. 1294-1303.
200. Ramsey, S.D., et al., *Quality of life in long term survivors of colorectal cancer*. Am J Gastroenterol, 2002. **97**(5): p. 1228-34.
201. Smith, D.M., et al., *Misremembering colostomies? Former patients give lower utility ratings than do current patients*. Health Psychol, 2006. **25**(6): p. 688-95.
202. Syngal, S., et al., *Benefits of colonoscopic surveillance and prophylactic colectomy in patients with hereditary nonpolyposis colorectal cancer mutations*. Annals of Internal Medicine, 1998. **129**(10): p. 787-96.
203. Ward, P., et al., *Physical function and quality of life in frail and/or elderly patients with metastatic colorectal cancer treated with capecitabine and bevacizumab: an exploratory analysis*. Journal of Geriatric Oncology, 2014. **5**(4): p. 368-75.
204. Brown, S.R., et al., *The impact of postoperative complications on long-term quality of life after curative colorectal cancer surgery*. Annals of Surgery, 2014. **259**(5): p. 916-23.
205. Downing, A., et al., *Health-related quality of life after colorectal cancer in England: a patient-reported outcomes study of individuals 12 to 36 months after diagnosis*. Journal of Clinical Oncology, 2015. **33**(6): p. 616-24.
206. Hall, P.S., et al., *Costs of cancer care for use in economic evaluation: a UK analysis of patient-level routine health system data*. British Journal of Cancer, 2015. **112**(5): p. 948-56.
207. Hompes, R., et al., *Evaluation of quality of life and function at 1 year after transanal endoscopic microsurgery*. Colorectal Disease, 2015. **17**(2): p. O54-O61.
208. Jordan, J., et al., *Laparoscopic versus open colorectal resection for cancer and polyps: A cost-effectiveness study*. ClinicoEconomics and Outcomes Research, 2014. **6**: p. 415-422.
209. Petrou, S. and N. Campbell, *Stabilisation in colorectal cancer*. International Journal of Palliative Nursing, 1997. **3**(5): p. 275.
210. Sharma, A., et al., *Predictors of early postoperative quality of life after elective resection for colorectal cancer*. Annals of Surgical Oncology, 2007. **14**(12): p. 3435-3442.
211. Wilson, T.R., D.J. Alexander, and P. Kind, *Measurement of health-related quality of life in the early follow-up of colon and rectal cancer*. Diseases of the Colon & Rectum, 2006. **49**(11): p. 1692-702.
212. Doornebosch, P.G., et al., *Impact of transanal endoscopic microsurgery on functional outcome and quality of life*. International Journal of Colorectal Disease, 2008. **23**(7): p. 709-713.
213. Doornebosch, P.G., et al., *Quality of life after transanal endoscopic microsurgery and total mesorectal excision in early rectal cancer*. Colorectal Disease, 2007. **9**(6): p. 553-558.
214. Gosselink, M.P., et al., *Quality of life after total mesorectal excision for rectal cancer*. Colorectal Disease, 2006. **8**(1): p. 15-22.
215. Kapidzic, A., et al., *Quality of life in participants of a CRC screening program*. Br J Cancer, 2012. **107**(8): p. 1295-301.

216. van den Brink, M., et al., *Cost-utility analysis of preoperative radiotherapy in patients with rectal cancer undergoing total mesorectal excision: a study of the Dutch Colorectal Cancer Group*. Journal of clinical oncology : official journal of the American Society of Clinical Oncology, 2004. **22**(2): p. 244-253.
217. Wiering, B., et al., *Added value of positron emission tomography imaging in the surgical treatment of colorectal liver metastases*. Nuclear Medicine Communications, 2010. **31**(11): p. 938-44.
218. Wiering, B., et al., *Long-term global quality of life in patients treated for colorectal liver metastases*. British Journal of Surgery, 2011. **98**(4): p. 565-71; discussion 571-2.
219. Boyd, N.F., et al., *Whose utilities for decision analysis?* Medical Decision Making, 1990. **10**(1): p. 58-67.
220. Dranitsaris, G., et al., *The application of pharmacoeconomic modelling to estimate a value-based price for new cancer drugs*. Journal of Evaluation in Clinical Practice, 2012b. **18**(2): p. 343-51.
221. Mittmann, N., et al., *Prospective cost-effectiveness analysis of cetuximab in metastatic colorectal cancer: Evaluation of national cancer institute of canada clinical trials group CO.17 Trial*. Journal of the National Cancer Institute, 2009. **101**(17): p. 1182-1192.
222. Lee, L., et al., *Valuing postoperative recovery: validation of the SF-6D health-state utility*. Journal of Surgical Research, 2013. **184**(1): p. 108-114.
223. Wong, C.K., et al., *Predicting SF-6D from the European Organization for Treatment and Research of Cancer Quality of Life Questionnaire scores in patients with colorectal cancer*. Value in Health, 2013a. **16**(2): p. 373-84.
224. Wong, C.K., et al., *Responsiveness was similar between direct and mapped SF-6D in colorectal cancer patients who declined*. Journal of Clinical Epidemiology, 2014. **67**(2): p. 219-27.
225. Yang, Y., et al., *Improving the mapping of condition-specific health-related quality of life onto SF-6D score*. Quality of life research : an international journal of quality of life aspects of treatment, care and rehabilitation, 2014. **23**(8): p. 2343-2353.
226. Wong, C.K., et al., *Mapping the Functional Assessment of Cancer Therapy-general or -Colorectal to SF-6D in Chinese patients with colorectal neoplasm*. Value in Health, 2012. **15**(3): p. 495-503.
227. Augestad, K.M., et al., *Cost-effectiveness and quality of life in surgeon versus general practitioner-organised colon cancer surveillance: A randomised controlled trial*. BMJ Open, 2013. **3**(4).
228. Hamashima, C., *Long-term quality of life of postoperative rectal cancer patients*. Journal of Gastroenterology & Hepatology, 2002. **17**(5): p. 571-6.
229. Kim, S.H., et al., *Mapping EORTC QLQ-C30 onto EQ-5D for the assessment of cancer patients*. Health Qual Life Outcomes, 2012b. **10**: p. 151.
230. Kim, S.H., et al., *Deriving a mapping algorithm for converting SF-36 scores to EQ-5D utility score in a Korean population*. Health and quality of life outcomes, 2014. **12**: p. 145.

231. Norum, J., et al., *Adjuvant chemotherapy (5-fluorouracil and levamisole) in Dukes' B and C colorectal carcinoma. A cost-effectiveness analysis.* *Annals of Oncology*, 1997. **8**(1): p. 65-70.
232. Shirowa, T., T. Fukuda, and K. Tsutani, *Cost-effectiveness analysis of XELOX for metastatic colorectal cancer based on the NO16966 and NO16967 trials.* *British Journal of Cancer*, 2009. **101**(1): p. 12-8.
233. Smith, R., et al., *A cost-utility approach to the use of 5-fluorouracil and levamisole as adjuvant chemotherapy for Dukes' C colonic carcinoma.* *Medical Journal of Australia*, 1993. **158**:319-322.
234. Young, C.J., et al., *Improving Quality of Life for People with Incurable Large-Bowel Obstruction: Randomized Control Trial of Colonic Stent Insertion.* *Diseases of the Colon & Rectum*, 2015. **58**(9): p. 838-49.
235. Cheung, Y.B., et al., *Mapping the English and Chinese versions of the Functional Assessment of Cancer Therapy-General to the EQ-5D utility index.* *Value Health*, 2009. **12**(2): p. 371-6.
236. Dranitsaris, G., et al., *A pharmacoeconomic modeling approach to estimate a value-based price for new oncology drugs in Europe.* *Journal of Oncology Pharmacy Practice*, 2012a. **18**(1): p. 57-67.
237. Dranitsaris, G., et al., *Using pharmacoeconomic modelling to determine value-based pricing for new pharmaceuticals in Malaysia.* *Malaysian Journal of Medical Sciences*, 2011b. **18**(4):31-42.
238. Dranitsaris, G., et al., *Improving patient access to cancer drugs in India: Using economic modeling to estimate a more affordable drug cost based on measures of societal value.* *International Journal of Technology Assessment in Health Care*, 2011a. **27**(1): p. 23-30.
239. Farkkila, N., et al., *Health-related quality of life in colorectal cancer.* *Colorectal Disease*, 2013. **15**(5): p. e215-e222.
240. Haapamaki, M.M., et al., *Physical performance and quality of life after extended abdominoperineal excision of rectum and reconstruction of the pelvic floor with gluteus maximus flap.* *Diseases of the Colon & Rectum*, 2011. **54**(1): p. 101-6.
241. Polat, U., et al., *Evaluation of quality of life and anxiety and depression levels in patients receiving chemotherapy for colorectal cancer: Impact of patient education before treatment initiation.* *Journal of Gastrointestinal Oncology*, 2014. **5**(4): p. 270-275.
242. Schwandner, O., *Sacral neuromodulation for fecal incontinence and "low anterior resection syndrome" following neoadjuvant therapy for rectal cancer.* *International Journal of Colorectal Disease*, 2013. **28**(5): p. 665-9.
243. Andersson, J., et al., *Health-related quality of life after laparoscopic and open surgery for rectal cancer in a randomized trial.* *British Journal of Surgery*, 2013. **100**(7): p. 941-9.
244. Bennett, L., et al., *Health-related quality of life in patients with metastatic colorectal cancer treated with panitumumab in first- or second-line treatment.* *Br J Cancer*, 2011. **105**(10): p. 1495-502.
245. Carter, H.E., et al., *The cost effectiveness of bevacizumab when added to capecitabine, with or without mitomycin-C, in first line treatment of metastatic colorectal cancer: Results from the Australasian phase III MAX study.* *European journal of cancer (Oxford, England : 1990)*, 2014. **50**(3): p. 535-543.

246. Odom, D., et al., *Health-related quality of life and colorectal cancer-specific symptoms in patients with chemotherapy-refractory metastatic disease treated with panitumumab*. Int J Colorectal Dis, 2011. **26**(2): p. 173-81.
247. Stein, D., et al., *Assessing health-state utility values in patients with metastatic colorectal cancer: a utility study in the United Kingdom and the Netherlands*. International Journal of Colorectal Disease, 2014. **29**(10): p. 1203-10.
248. Wang, J., et al., *A Q-TWiST analysis comparing panitumumab plus best supportive care (BSC) with BSC alone in patients with wild-type KRAS metastatic colorectal cancer*. Br J Cancer, 2011. **104**(12): p. 1848-53.
249. Rowen, D., et al., *Deriving a preference-based measure for cancer using the EORTC QLQ-C30*. Value Health, 2011. **14**(5): p. 721-31.
250. Norman, R., et al., *Using a discrete choice experiment to value the QLU-C10D: feasibility and sensitivity to presentation format*. Qual Life Res, 2016. **25**(3): p. 637-49.
251. McKenzie, L. and M. van der Pol, *Mapping the EORTC QLQ C-30 onto the EQ-5D instrument: the potential to estimate QALYs without generic preference data*. Value Health, 2009. **12**(1): p. 167-71.
252. Teckle, P., et al., *Mapping the FACT-G cancer-specific quality of life instrument to the EQ-5D and SF-6D*. Health Qual Life Outcomes, 2013. **11**: p. 203.
253. Dolan, P., *Modeling valuations for EuroQol health states*. Med Care, 1997. **35**(11): p. 1095-108.
254. Kind, P., et al., *Variations in population health status: results from a United Kingdom national questionnaire survey*. Bmj, 1998. **316**(7133): p. 736-41.
255. Weinstein, M.C., et al., *Recommendations of the Panel on Cost-effectiveness in Health and Medicine*. JAMA, 1996. **276**(15): p. 1253-8.
256. Burke, M.J., R. Sidhu, and E. George, *PCN158 - Utility Values Used in National Institute for Health and Care Excellence (NICE) Technology Appraisals of Medicines for 4 Metastatic Cancers*. Value in Health, 2013. **16**(7): p. A420.
257. Glaser, A.W., et al., *Patient-reported outcomes of cancer survivors in England 1-5 years after diagnosis: A cross-sectional survey*. BMJ Open, 2013. **3**(4).
258. Brazier, J. and S. Dixon, *The use of condition specific outcome measures in economic appraisal*. Health Econ, 1995. **4**(4): p. 255-64.
259. Jeong, K.E. and J.A. Cairns, *Systematic review of health state utility values for economic evaluation of colorectal cancer*. Health Economics Review, 2016. **6**(1): p. 1-10.
260. Park, S.M., et al., *Cost-effectiveness Analysis of Colorectal Cancer Screening in Korean General Population*. 가정의학회지 = Family physician : journal of the Korean Academy of Family Medicine, 2004. **25**(4): p. 297-306.
261. Han, D., et al., *Cost-effectiveness analysis of colon cancer screening by colonoscopic examination in Korea 한국인 대장암의 선별검사로써 대장내시경 검사의 비용-효과분석*. 대한소화기내시경학회지, 2004. **28**(1): p. 1-8.

262. Jeong, S.H.정., *확률론적 모형을 이용한 우리나라 암 조기검진 전략*, in *연세대학교 대학원 : 보건학과*. 2008, 연세대학교 대학원 : 보건학과: Korea.
263. Kim, Y., *국가 암 조기검진의 비용-효과 분석 모형 개발 (0320440-1) Model Development for Cost-Effectiveness Analysis of National Cancer Screening Programs*, S. University, Editor. 2004.
264. NCC, *대장암 검진 권고안*. 2015, National Cancer Center: Korea. p. 1-118.
265. NICE. *Process and methods guides. Developing NICE guidelines: the manual*. 2014; Available from: <https://www.nice.org.uk/media/default/about/what-we-do/our-programmes/developing-nice-guidelines-the-manual.pdf>.
266. Siebert, U., et al., *State-transition modeling: a report of the ISPOR-SMDM Modeling Good Research Practices Task Force--3*. Value Health, 2012. **15**(6): p. 812-20.
267. Brenner, H., et al., *Risk of progression of advanced adenomas to colorectal cancer by age and sex: estimates based on 840,149 screening colonoscopies*. Gut, 2007. **56**(11): p. 1585-9.
268. Brenner, H., L. Altenhofen, and M. Hoffmeister, *Sex, age, and birth cohort effects in colorectal neoplasms: a cohort analysis*. Ann Intern Med, 2010. **152**(11): p. 697-703.
269. Nickerson, C., *Data received from NHS Bowel Cancer Screening Programme*. 2010.
270. Zorzi, M., et al., *Screening for colorectal cancer in Italy: 2007 survey*. Epidemiol Prev, 2009. **33**(3 Suppl 2): p. 57-74.
271. Briggs, A., K. Claxton, and M. Sculpher, *Decision Medelling for Health Economic Evaluation*. Handbooks in Health Economic Evaluation Series, ed. A. Gray and A. Briggs. 2006, Oxford: Oxford University Press.
272. Hong, C.W., *Korean Colorectal Polyp Registry 한국인 대장용종 등록사업*. 2009, National Cancer Center: Korea.
273. Briggs, A.H., A.E. Ades, and M.J. Price, *Probabilistic sensitivity analysis for decision trees with multiple branches: use of the Dirichlet distribution in a Bayesian framework*. Med Decis Making, 2003. **23**(4): p. 341-50.
274. Park, E., *Evaluation of National Cancer Screening infrastructure and development of quality control strategy 암 조기검진 확대에 따른 인프라 구축 및 질 관리 방안연구*. 2005, MoHW: Korea. p. 1-250.
275. Jeong, G., K. Kim, and Y. Kwak, *Quality of Life in Colorectal Cancer Patients according to the Severity of Symptom Clusters Classification 대장암 환자 증상군의 중증도에 따른 삶의 질*. Asian Oncology Nursing, 2014. **14**(2): p. 74-83.
276. Lee, Y.H., et al., *EuroQoL-5 Dimension 한국 가중치 모형의 적용 연구*. Journal of Korean Society for Health Education and Promotion, 2009. **26**(1): p. 1-13.
277. Kirkoen, B., et al., *Do no harm: no psychological harm from colorectal cancer screening*. Br J Cancer, 2016. **114**(5): p. 497-504.

278. Mogyorosy, Z. and P. Smith, *The main methodological issues in costing health care services: A literature review in Healthbasket Project*. 2005, Centre for Health Economics, The University of York: York. p. 1-232.
279. Noh, J., *위대장 수면내시경 검사비 9 배 격차*. 2015, Sisa Press Korea.
280. YTN. <금요기획> "의료수가는 낮다는데 왜 병원비는 비쌀까요?"-연세대 보건행정학과 정형선 교수. 2014 [cited 2015 1 February]; Available from: http://radio.ytn.co.kr/program/?f=2&id=29181&s_mcd=0206&s_hcd=15.
281. OECD. *OECD Health statistics 2015*. 2015 [cited 2015 07 July 2015]; Available from: <http://www.oecd.org/els/health-systems/Country-Note-KOREA-OECD-Health-Statistics-2015.pdf>.
282. HIRA, *항암요법 요양 급여적용기준*. 2014, HIRA: Korea.
283. Lee, E.S., *Enhancement and activation of Korean Cancer Outcomes Research 한국인 암 진료 성과 연구의 고도화 및 활성화*. 2012, National Cancer Centre: Korea.
284. Seo, N.K., et al., *2013 년 한국의료패널 심층분석보고서 - 한국의료패널을 활용한 보건의료지표 개발연구*. 2013, NHIS and KIHASA: Korea.
285. Ahn, C.W., *미국 내시경 수가, 한국의 19~95 배*, in *MEDI:AGTE NEWS*. 2015, MEDI: Korea.
286. Kim, J., et al., *항암화학요법으로 인한 말초신경병증을 경험하는 대장암 환자의 삶의 질*. *종양간호학회지 = Journal of Korean oncology nursing*, 2011. **11**(3): p. 254-262.
287. Ahn, J., et al., *Research on methodologies for evidence-based healthcare decision-making processes in Korea 근거중심의 진료에 맞는 한국적인 보건 의사결정을 위한 방법론 연구*. 2010, NECA (National Evidence-based Healthcare Collaborating Agency): Seoul, Korea.
288. Briggs, A., *Transportability of comparative effectiveness and cost-effectiveness between countries*. *Value Health*, 2010. **13 Suppl 1**: p. S22-5.
289. O'Brien, B.J., *A tale of two (or more) cities: geographic transferability of pharmaco-economic data*. *Am J Manag Care*, 1997. **3 Suppl**: p. S33-9.
290. Yim, E.Y., et al., *Assessment of pharmaco-economic evaluations submitted for reimbursement in Korea*. *Value Health*, 2012. **15**(1 Suppl): p. S104-10.
291. Ng, S.C. and S.H. Wong, *Colorectal cancer screening in Asia*. *British Medical Bulletin*, 2013. **105**(1): p. 29-42.
292. Kind, P. and S. Macran, *Eliciting social preference weights for Functional Assessment of Cancer Therapy-Lung health states*. *Pharmacoeconomics*, 2005. **23**(11): p. 1143-53.

APPENDICES

APPENDICES TO CHAPTER 2

Figure A2.1 Institutional Review Board (IRB), Seoul Bundang Hospital

[서식 8] II.A.3-심의면제 결과통보서

분당서울대학교병원 생명윤리심의위원회

Tel : 031-787-1376-9
 FAX : 031-787-4025 주소: 경기도 성남시 분당구 구미로 173번길 82 우) 463-707

심의면제 결과통보서

IRB No.	X-1411/276-902					
수신	책임연구자	이희영	소속	공공의료사업단	직위	교수(촉탁교수이상)
	의뢰기관 또는 연구비 지원기관					
제출경로	분당서울대학교병원					
연구과제명	건강보험공단 자료를 이용한 대장암 검진의 비용 효과분석 연구					
심의대상	심의면제 의뢰서					
접수일	2014-11-13					
심의일	2014-11-14					
심의목록	1. 연구계획서 요약 2. 연구대상자 동의 면제 사유서 3. 연구책임자의 최근 이력 또는 기타경력에 관한 문서					
심의의견	심의면제 일반 대중에서 공개된 정보를 이용하는 연구로, 연구대상자의 권리를 침해하지 않고, 위험을 주지 않을 연구로 확인하여 심의면제 함.					

생명 윤리 심 의 위 원 회 위 원 장

본 통보서에 기재된 사항은 IRB의 기록된 내용과 일치함을 증명합니다.

본 기관 IRB는 생명윤리 및 안전에 관한 법률, 약사법, 의료기기법 및 ICH-GCP 등 관련 법규를 준수합니다.

본 연구와 이해상충(Conflict of Interest)이 있는 위원이 있을 경우 연구의 심의에서 배제하였습니다.

Figure A2.2 Reporting form CRCS, NHI (2009)

[별지 제13호의 3서식의 별첨]

대장암 검진 결과 기록지

일반건강검진

생애전환기 건강진단

성명	주민등록번호	-	연락처	
자격구분	<input type="checkbox"/> 건강보험가입자 <input type="checkbox"/> 의료급여수급권자		통보처	국가암보건소 ()
주소	우 - ,			

구분	검사항목 (검사일 및 검사장소)	검사결과
대장암	분변잠혈반응검사 년 월 일 <input type="checkbox"/> 내원 <input type="checkbox"/> 출장	<input type="checkbox"/> 정상검사 : 1. 음성 2. 양성 <input type="checkbox"/> 정량검사 : 1. 음성 2. 양성 검사결과: (ng/ml) [기준치: (ng/ml 이하)]
	대장이종 조영검사 년 월 일 내원	1. 정상 2. 대장용종 (크기: mm) 3. 대장암 의심 4. 대장암 5. 기타 <input type="checkbox"/> 치핵 <input type="checkbox"/> 비특이성 장염 <input type="checkbox"/> 허혈성 장염 <input type="checkbox"/> 궤양성 대장염 <input type="checkbox"/> 크론병 <input type="checkbox"/> 장결핵 <input type="checkbox"/> 대장 계실증 <input type="checkbox"/> 대장 점막하종양 <input type="checkbox"/> 림프구 증식 <input type="checkbox"/> 직결기입()
	병변위치 ※ 관속소진 필요를 위 차에 따라 괄호에 최 대 3자리까지 기입	1. 회장 말단부 () 2. 맹장 () 3. 상행 결장 () 4. 간 만곡 () 5. 횡행 결장 () 6. 비 만곡 () 7. 하행 결장 () 8. 에스 결장 () 9. 직장 () 10. 항문 ()
	대장내시경검사 년 월 일 내원	1. 필요 2. 불필요 1. 정상 2. 대장용종 (크기: mm/절제치치 <input type="checkbox"/> 실시 <input type="checkbox"/> 미실시) 3. 대장암 의심 4. 대장암 5. 기타 <input type="checkbox"/> 치핵 <input type="checkbox"/> 비특이성 장염 <input type="checkbox"/> 허혈성 장염 <input type="checkbox"/> 궤양성 대장염 <input type="checkbox"/> 크론병 <input type="checkbox"/> 장결핵 <input type="checkbox"/> 대장 계실증 <input type="checkbox"/> 대장 점막하종양 <input type="checkbox"/> 림프구 증식 <input type="checkbox"/> 직결기입()
	병변위치 ※ 관속소진 필요를 위 차에 따라 괄호에 최 대 3자리까지 기입	1. 회장 말단부 () 2. 맹장 () 3. 상행 결장 () 4. 간 만곡 () 5. 횡행 결장 () 6. 비 만곡 () 7. 하행 결장 () 8. 에스 결장 () 9. 직장 () 10. 항문 ()
조직진단 ※ 조직진단 실시하지 않았을 경우 기입 불필요 ※ 조직진단 다수일 경우 가장 중한 진단기입	1. 필요 2. 불필요 1. 정상 2. 염증성 또는 증식성 병변 3. 저도선종 또는 이행성 4. 고도선종 또는 이행성 5. 암의심 6. 암 <input type="checkbox"/> 샘암종(고분화, 중분화, 저분화) <input type="checkbox"/> 점액(샘)암종 <input type="checkbox"/> 반지세포암종 <input type="checkbox"/> 샘편평상피암종 <input type="checkbox"/> 편평상피암종 <input type="checkbox"/> 소세포암종 <input type="checkbox"/> 수질암종 <input type="checkbox"/> 미분화 암종 <input type="checkbox"/> 악성림프종 <input type="checkbox"/> 신경내분비종양(맹장과 직장의 1cm이하 종양제외) <input type="checkbox"/> 직결기입() 7. 기타 <input type="checkbox"/> 신경내분비종양 <input type="checkbox"/> 비상피성종양 <input type="checkbox"/> 항문암 <input type="checkbox"/> 말단회장부위 암 <input type="checkbox"/> 직결기입()	

판정 및 권고	판정구분		권고사항	
	※ 검사결과에 따라 판정구분이 다수일 경우 가장 중한 판정구분을 기입		※ 판정구분에 따른 판정기준 기입 이외에 별도로 300자 이내로 기입	
	1. 음성 2. 양성 또는 1. 정상 2. 양성질환 3. 대장암 의심 4. 대장암 5. 기타 () <input type="checkbox"/> 기존 대장암환자			
결과통보일 년 월 일	판정일 년 월 일	판정 의사	면허번호 의사명 (서명)	

Figure A2.3 CRCS mapping pathways I

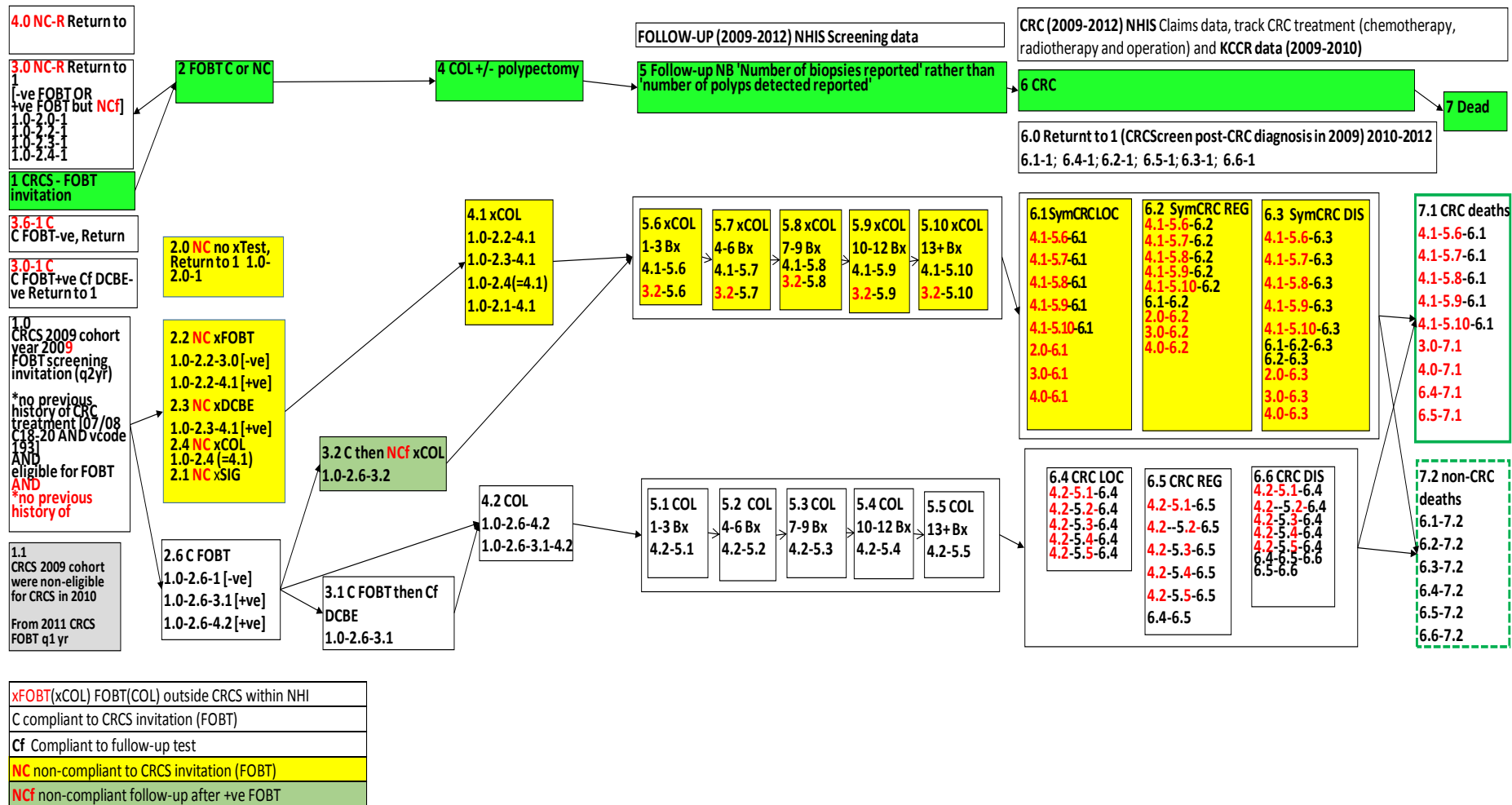

Table A2.1 CRCS mapping pathways II

	Pathway	Pathway Definition	Group
1	1.0-2.0-1	NC FOBT then and no CRC	H
2	1.0-2.1-1	NC FOBT then xSIG and no CRC	F
3	1.0-2.2-1	NC FOBT then xFOBT and no CRC	F
4	1.0-2.3-1	NC FOBT then xDCBE and no CRC	F
5	1.0-2.4-1	NC FOBT then xCOL and no CRC	F
6	1.0-2.0-1-6.1 (alive)	NC FOBT then CRC LOC diagnosis	G
7	1.0-2.0-1-6.2 (alive)	NC FOBT then CRC REG diagnosis	G
8	1.0-2.0-1-6.3 (alive)	NC FOBT then CRC DIS diagnosis	G
9	1.0-2.2-1-6.1 (alive)	NC FOBT, xTESTs then CRC LOC diagnosis	E
10	1.0-2.2-1-6.2 (alive)	NC FOBT, xTESTs then CRC REG diagnosis	E
11	1.0-2.2-1-6.3 (alive)	NC FOBT, xTESTs then CRC DIS diagnosis	E
12	1.0-2.6-1	C FOBT return to CRC cohort 1	D
13	1.0-2.6-4.2-1	C FOBT, COL then no CRC	D
14	1.0-2.6-6.4	C FOBT, CRC LOC after 90days (90d)	B
15	1.0-2.6-6.5	C FOBT, CRC REG after 90d	B
16	1.0-2.6-6.6	C FOBT, CRC DIS after 90d	B
17	1.0-2.6-4.2-5.1	C FOBT, COL then COL Bx 1-3 and nCRC	D
18	1.0-2.6-4.2-5.1-6.4	C FOBT, COL then COL Bx 1-3, CRC LOC in 90d	A
19	1.0-2.6-4.2-5.1-6.4	C FOBT, COL then COL Bx 1-3, CRC LOC after 90d	C
20	1.0-2.6-4.2-5.1-6.5	C FOBT, COL then COL Bx 1-3, CRC REG in 90d	A
21	1.0-2.6-4.2-5.1-6.5	C FOBT, COL then COL Bx 1-3, CRC REG after 90d	C
22	1.0-2.6-4.2-5.1-6.6	C FOBT, COL then COL Bx 1-3, CRC DIS in 90d	A
23	1.0-2.6-4.2-5.1-6.6	C FOBT, COL then COL Bx 1-3, CRC DIS after 90d	C
24	1.0-2.6-4.2-5.2	C FOBT, COL then COL Bx 4-6 and nCRC	D
25	1.0-2.6-4.2-5.2-6.4	C FOBT, COL then COL Bx 4-6, then CRC LOC in 90d	A
26	1.0-2.6-4.2-5.2-6.4	C FOBT, COL then COL Bx 4-6, then CRC LOC after 90d	C
27	1.0-2.6-4.2-5.2-6.5	C FOBT, COL then COL Bx 4-6, then CRC REG in 90d	A
28	1.0-2.6-4.2-5.2-6.5	C FOBT, COL then COL Bx 4-6, then CRC REG after 90d	C
29	1.0-2.6-4.2-5.2-6.6	C FOBT, COL then COL Bx 4-6, then CRC DIS in 90d	A
30	1.0-2.6-4.2-5.2-6.6	C FOBT, COL then COL Bx 4-6, then CRC DIS after 90d	C
31	1.0-2.6-4.2-5.3	C FOBT, COL then COL Bx 7-9 and nCRC	D
32	1.0-2.6-4.2-5.3-6.4	C FOBT, COL then COL Bx 7-9, then CRC LOC in 90d	A
33	1.0-2.6-4.2-5.3-6.4	C FOBT, COL then COL Bx 7-9, then CRC LOC after 90d	C
34	1.0-2.6-4.2-5.3-6.5	C FOBT, COL then COL Bx 7-9, then CRC REG in 90d	A
35	1.0-2.6-4.2-5.3-6.5	C FOBT, COL then COL Bx 7-9, then CRC REG after 90d	C
36	1.0-2.6-4.2-5.3-6.6	C FOBT, COL then COL Bx 7-9, then CRC DIS in 90d	A
37	1.0-2.6-4.2-5.3-6.6	C FOBT, COL then COL Bx 7-9, then CRC DIS after 90d	C
38	1.0-2.6-4.2-5.4	C FOBT, COL then COL Bx 10-12 and nCRC	D
39	1.0-2.6-4.2-5.4-6.4	C FOBT, COL then COL Bx 10-12, CRC LOC in 90d	A
40	1.0-2.6-4.2-5.4-6.4	C FOBT, COL then COL Bx 10-12, CRC LOC after 90d	C
41	1.0-2.6-4.2-5.4-6.5	C FOBT, COL then COL Bx 10-12, CRC REG in 90d	A
42	1.0-2.6-4.2-5.4-6.5	C FOBT, COL then COL Bx 10-12, CRC REG after 90d	C
43	1.0-2.6-4.2-5.4-6.6	C FOBT, COL then COL Bx 10-12, CRC DIS in 90d	A
44	1.0-2.6-4.2-5.4-6.6	C FOBT, COL then COL Bx 10-12, CRC DIS after 90d	C

	Pathway	Pathway Definition	Group
45	1.0-2.6-4.2-5.5	C FOBT, COL then COL Bx 13+, nCRC	D
46	1.0-2.6-4.2-5.5-6.4	C FOBT, COL then COL Bx 13+, CRC LOC in 90 days	A
47	1.0-2.6-4.2-5.5-6.4	C FOBT, COL then COL Bx 13+, CRC LOC after 90d	C
48	1.0-2.6-4.2-5.5-6.5	C FOBT, COL then COL Bx 13+, CRC REG in 90 days	A
49	1.0-2.6-4.2-5.5-6.5	C FOBT, COL then COL Bx 13+, CRC Reg after 90d	C
50	1.0-2.6-4.2-5.5-6.6	C FOBT, COL then COL Bx 13+, CRC DIS in 90d	A
51	1.0-2.6-4.2-5.5-6.6	C FOBT, COL then COL Bx 13+, CRC DIS after 90d	C
52	1.0-2.6-4.2-5.1	C FOBT-ve then xCOL Bx 1-3	M
53	1.0-2.6-4.2-5.1-6.4	C FOBT-ve then xCOL Bx 1-3, CRC LOC	L
54	1.0-2.6-4.2-5.1-6.5	C FOBT-ve then xCOL Bx 1-3, CRC REG	L
55	1.0-2.6-4.2-5.1-6.6	C FOBT-ve then xCOL Bx 1-3, CRC DIS	L
56	1.0-2.6-4.2-5.2	C FOBT-ve, then xCOL Bx 4-6	M
57	1.0-2.6-4.2-5.2-6.4	C FOBT-ve then xCOL Bx 4-6, then CRC LOC	L
58	1.0-2.6-4.2-5.2-6.5	C FOBT-ve then xCOL Bx 4-6, then CRC REG	L
59	1.0-2.6-4.2-5.2-6.6	C FOBT-ve thenx COL Bx 4-6, then CRC DIS	L
60	1.0-2.6-4.2-5.3	C FOBT-ve then xCOL Bx 7-9	M
61	1.0-2.6-4.2-5.3-6.4	C FOBT-ve then xCOL Bx 7-9, then CRC LOC	L
62	1.0-2.6-4.2-5.3-6.5	C FOBT-ve then xCOL Bx 7-9, then CRC REG	L
63	1.0-2.6-4.2-5.3-6.6	C FOBT-ve then xCOL Bx 7-9, then CRC DIS	L
64	1.0-2.6-4.2-5.4	C FOBT-ve then xCOL Bx 10-12	M
65	1.0-2.6-4.2-5.4-6.4	C FOBT-ve then xCOL Bx 10-12, CRC LOC	L
66	1.0-2.6-4.2-5.4-6.5	C FOBT-ve then xCOL Bx 10-12, CRC REG	L
67	1.0-2.6-4.2-5.4-6.6	C FOBT-ve then xCOL Bx 10-12, CRC DIS	L
68	1.0-2.6-4.2-5.5	C FOBT-ve then xCOL Bx 13 and more	M
69	1.0-2.6-4.2-5.5-6.4	C FOBT-ve then xCOL Bx 13 and more, CRC LOC	L
70	1.0-2.6-4.2-5.5-6.5	C FOBT-ve then xCOL Bx 13 and more, CRC REG	L
71	1.0-2.6-4.2-5.5-6.6	C FOBT-ve then xCOL Bx 13 and more, CRC DIS	L
72	1.0-2.6-3.2-4.3-5.6	C FOBT but NCf, xCOL Bx 1-3	K
73	1.0-2.6-3.2-4.3-5.6-6.1	C FOBT NCf, xCOL Bx 1-3, CRC LOC	I
74	1.0-2.6-3.2-4.3-5.6-6.1	C FOBT NCf, xCOL Bx 1-3, CRC REG	I
75	1.0-2.6-3.2-4.3-5.6-6.3	C FOBT NCf, xCOL COL Bx 1-3, CRC DIS	I
76	1.0-2.6-3.2-4.3-5.7	C FOBT NCf, xCOL COL Bx 4-6	K
77	1.0-2.6-3.2-4.3-5.7-6.1	C FOBT NCf, xCOL COL Bx 4-6, CRC LOC	I
78	1.0-2.6-3.2-4.3-5.7-6.2	C FOBT NCf, xCOL COL Bx 4-6, CRC REG	I
79	1.0-2.6-3.2-4.3-5.7-6.3	C FOBT NCf, xCOL COL Bx 4-6, CRC DIS	I
80	1.0-2.6-3.2-4.3-5.8	C FOBT NCf xCOL Bx 7-9	K
81	1.0-2.6-3.2-4.3-5.8-6.1	C FOBT NCf, xCOL Bx 7-9, CRC LOC	I
82	1.0-2.6-3.2-4.3-5.8-6.2	C FOBT NCf, xCOL Bx 7-9, CRC REG	I
83	1.0-2.6-3.2-4.3-5.8-6.3	C FOBT NCf, xCOL Bx 7-9, CRC DIS	I
84	1.0-2.6-3.2-4.3-5.9	C FOBT NCf xCOL Bx 10-12	K
85	1.0-2.6-3.2-4.3-5.9-6.1	C FOBT NCf, xCOL Bx 10-12, CRC LOC	I
86	1.0-2.6-3.2-4.3-5.9-6.2	C FOBT NCf, xCOL Bx 10-12, CRC REG	I
87	1.0-2.6-3.2-4.3-5.9-6.3	C FOBT NCf, xCOL Bx 10-12, CRC DIS	I
88	1.0-2.6-3.2-4.3-5.10	C FOBT but NCf xCOL Bx 13 and more	K
89	1.0-2.6-3.2-4.3-5.10-6.1	C FOBT NCf, xCOL Bx 13, CRC LOC	I
90	1.0-2.6-3.2-4.3-5.10-6.2	C FOBT NCf, xCOL Bx 13, CRC REG	I
91	1.0-2.6-3.2-4.3-5.10-6.3	C FOBT NCf, xCOL Bx 13, CRC DIS	I
92	1.0-2.6-3.1-4.2-5.6	C FOBT, C DCBE then xCOL Bx 1-3	K
93	1.0-2.6-3.1-4.2-5.6-6.4	C FOBT, Cf DCBE then xCOL Bx 1-3, CRC LOC	J
94	1.0-2.6-3.1-4.2-5.6-6.5	C FOBT, Cf DCBE then xCOL Bx 1-3, CRC REG	J
95	1.0-2.6-3.1-4.2-5.6-6.6	C FOBT, Cf DCBE then xCOL Bx 1-3, CRC DIS	J

	Pathway	Pathway Definition	Group
96	1.0-2.6-3.1-4.2-5.7	C FOBT, Cf DCBE then xCOL Bx 4-6	K
97	1.0-2.6-3.1-4.2-5.7-6.4	C FOBT, Cf DCBE then xCOL Bx 4-6, CRC LOC in 90d	J
98	1.0-2.6-3.1-4.2-5.7-6.5	C FOBT, Cf DCBE then xCOL Bx 4-6, CRC REG in 90d	J
99	1.0-2.6-3.1-4.2-5.7-6.6	C FOBT, Cf DCBE then xCOL Bx 4-6, CRC DIS in 90d	J
100	1.0-2.6-3.1-4.2-5.8	C FOBT, Cf DCBE then xCOL Bx 7-9	K
101	1.0-2.6-3.1-4.2-5.8-6.4	C FOBT, Cf DCBE then xCOL Bx 7-9, CRC LOC in 90d	J
102	1.0-2.6-3.1-4.2-5.8-6.5	C FOBT, Cf DCBE then xCOL Bx 7-9, CRC REG in 90d	J
103	1.0-2.6-3.1-4.2-5.8-6.6	C FOBT, Cf DCBE then xCOL Bx 7-9, CRC DIS in 90d	J
104	1.0-2.6-3.1-4.2-5.9	C FOBT+ve, Cf DCBE+ve then xCOL	K
105	1.0-2.6-3.1-4.2-5.9-6.4	C FOBT, Cf DCBE then xCOL Bx 10-12, CRC LOC in 90d	J
106	1.0-2.6-3.1-4.2-5.9-6.5	C FOBT, Cf DCBE then xCOL Bx 10-12, CRC REG in 90d	J
107	1.0-2.6-3.1-4.2-5.9-6.6	C FOBT, Cf DCBE then xCOL Bx 10-12, CRC DIS in 90d	J
108	1.0-2.6-3.1-4.2-5.10	C FOBT+ve, Cf DCBE+ve then xCOL	K
109	1.0-2.6-3.1-4.2-5.10-6.4	C FOBT, Cf DCBE then xCOL Bx 13+CRC LOC in 90d	J
110	1.0-2.6-3.1-4.2-5.10-6.5	C FOBT, Cf DCBE then xCOL Bx 13+ CRC REG in 90d	J
111	1.0-2.6-3.1-4.2-5.10-6.6	C FOBT, Cf DCBE then xCOL Bx 13+ CRC DIS in 90d	J

90d 90 days; **Bx**; biopsies; **C** compliant CRCS invitation; **Cf** compliant follow-up; **COL** colonoscopy; **CRC** colorectal cancer; **CRCS** colorectal cancer screening; **DCBE** double-contrast barium enema; **DIS** distant; **Dx** diagnosis; **LOC** Localised; **NC** non-compliant FOBT; **Ncf** non-compliant follow-up; **NHI** National Health Insurance; **REG** regional; **rHCU** Healthcare utilisation CRCS (xTests) then CRC Tx; **symCRC** symptomatic CRC (no CRCS done); **tCRC** CRCS FOBT negative then 90 days later CRC Tx; **Tx** treatment; **xFOBT** FOBT outside CRCS within NHI; **xSIG** sigmoidoscopy outside CRCS within NHI; **xDCBE** DCBE outside CRCS within NHI; **xCOL** COL outside CRCS within NHI; **zHCU** Healthcare utilisation CRCS only (xTests outside CRCS within NHI); **+ve** positive; **-ve** negative
Group A-D CRCS only; E-F HCSU only; G-H NC; I-K CRCS positive then HCSU; L-M CRCS negative results then HCSU

Table A2.2 Summary of recommended chemotherapy agents for CRC

Primary chemotherapy agents	Indications	Reference
Fluorouracil + leucovorin	Clinician's judgement	HIRA (2015)
Fluorouracil + cisplatin	Clinician's judgement	HIRA (2015)
Fluorouracil + leucovorin + cisplatin	Clinician's judgement	HIRA (2015)
Fluorouracil + leucovorin + carboplatin	Clinician's judgement	HIRA (2015)
Tegafur + uracil + leucovorin (oral)	Clinician's judgement	HIRA (2015)
leucovorin (oral)	Clinician's judgement	HIRA (2015)
Tegafur + uracil + leucovorin (oral) + cisplatin	Clinician's judgement	HIRA (2015)
leucovorin (oral) + cisplatin	Clinician's judgement	HIRA (2015)
Mitomycin C	Clinician's judgement	HIRA (2015)
Mitomycin C + leucovorin (oral)	Clinician's judgement	HIRA (2015)
Mitomycin C + tegafur + uracil + leucovorin (oral)	Clinician's judgement	HIRA (2015)
Cisplatin	Clinician's judgement	HIRA (2015)
Etoposide (intravenous or oral)	Clinician's judgement	HIRA (2015)
Secondary chemotherapy agents		HIRA (2015)
Neoadjuvant		HIRA (2015)
Capecitabine + radiotherapy	CRC Stages II & III	HIRA (2015)
Oxaliplatin + leucovorin + infusional fluorouracil (FOLFOX)	CRC stage II (post-operative) CRC stage III	HIRA (2015)
Capecitabine	CRC stage II (post-operative) CRC stage III	HIRA (2015)
Oxaliplatin + capecitabine	CRC stage III	HIRA (2015)
Palliative		
Irinotecan + leucovorin fluorouracil (infusion)(FOLFIRI) + bevacizumab	Metastasis	HIRA (2015)
Irinotecan + leucovorin + fluorouracil (infusion) (FOLFIRI) + cetuximab	EGFR positive, KRAS wild-type metastatic CRC	HIRA (2015)
Irinotecan + leucovorin + fluorouracil (infusion) (FOLFIRI) + bevacizumab	Metastasis	HIRA (2015)
Oxaliplatin + leucovorin + fluorouracil (infusion) (FOLFOX) + bevacizumab	Metastasis	HIRA (2015)

CRC colorectal cancer; **EGFR** epidermal growth factor receptor; **KRAS** mutations in the Kirsten Ras gene

APPENDICES TO CHAPTER 3

Table A3.1 Search strategy - MEDLINE

Database(s): Ovid MEDLINE(R) In-Process & Other Non-Indexed Citations and Ovid MEDLINE(R) 1946 to Present		
#	Searches	Results
1	((colorectal or colon\$ or rectum or rectal) adj2 (cancer\$ or tumour\$ or tumor\$ or neoplasm\$ or carcinoma\$ or adenoma\$ or polyp\$)).ti,ab.	115391
2	Colonoscopy/	16294
3	colonoscop\$.ti,ab.	16760
4	sigmoidoscop\$.ti,ab.	3592
5	exp Mass Screening/	93902
6	exp Population Surveillance/	46155
7	Diagnostic tests, routine/	6251
8	screen\$.ti,ab.	415503
9	2 or 3 or 4	26014
10	5 or 6 or 7 or 8	495330
11	1 and 9 and 10	4432
12	limit 11 to yr="1999 -Current"	3671
13	Economics/ or exp "Costs and Cost Analysis"/ or Economics, Dental/ or exp Economics, Hospital/ or exp Economics, Medical/ or Economics, Nursing/ or Economics, Pharmaceutical/ or Budgets/ or exp Models, Economic/ or Markov Chains/ or Monte Carlo Method/ or Decision Trees/	256934
14	(Economic* or cost or costs or costly or costing or costed or price or prices or pricing or pharmacoeconomic\$ or pharmaco economic\$ or budget*).ti,ab.	420310
15	((monte adj carlo) or markov or (decision adj2 (tree\$ or analys\$))).ti,ab.	40324
16	Quality-Adjusted Life Years/	6140
17	(quality adjusted life or qaly*).ti,ab.	6297
18	(disability adjusted life or daly).ti,ab.	1231
19	(value adj2 (money or monetary)).ti,ab.	1173
20	13 or 14 or 15 or 16 or 17 or 18 or 19	580430
21	12 and 20	610

Table A3.2 Further details – Study selection criteria

Inclusion criteria	Full economic evaluations that considered costs and health outcomes of relevant types of interventions with outcomes expressed in cost per quality-adjusted life-year (QALY) or cost per life-year gained. The population considered was adults with confirmed colorectal adenoma/polyp who are otherwise healthy with no personal or familial history of CRC. Follow-up strategies and screening strategies based on the best available evidence on the screening modalities were considered, including current practice and no intervention.
Exclusion criteria	Burden of disease studies or non-comparative costing studies were excluded. Any studies which did not assess costs and related health outcomes in line with the research questions were excluded. Clinical investigation or therapeutic interventions for suspected CRC or conditions other than colorectal adenoma/polyp were not considered.
Screening	Title and abstracts were screened and papers that did not meet the inclusion criteria were excluded. Full text was acquired for the remaining studies. When studies presented insufficient detail (for example, no abstract available) full-text was reviewed. All abstracts were screened, and any disagreements were resolved by discussion between two reviewers.
Data extraction	Data were extracted on author(s), year of publication, modelling approach, screening modalities, population groups, perspective of analysis and analytic horizon, effectiveness data sources, outcome measures, cost elements, cost data sources, year of costing reported, adjustment for inflation, discount rate, baseline results, variables used in the results and sensitivity analyses, reported limitations, reported model validation and reported conclusion. In addition, modelled strategies for follow-up of positive results from first-line screening and follow-up of adenoma/polyp and CRC treatments were reviewed.

Appendix Table A3.3 Included/excluded studies

Table A3.3.1 Included studies

1	Chauvin, P., J.M. Josselin, and D. Heresbach, Incremental net benefit and acceptability of alternative health policies: A case study of mass screening for colorectal cancer. <i>European Journal of Health Economics</i> , 2012. 13(3): p. 237-250.
2	Dan, Y.Y., et al., Screening based on risk for colorectal cancer is the most cost-effective approach. <i>Clinical Gastroenterology & Hepatology</i> , 2012. 10(3): p. 266-71.e1-6.
3	Di Bidino, R., et al., Impact of technology overlapping: a case study on colorectal cancer screening. <i>Technology & Health Care</i> , 2010. 18(4-5): p. 303-15.
4	Eddy, D.M., Screening for colorectal cancer. <i>American Journal of Physicians</i> , 1990. 113: p. 373-384.
5	Flanagan, W.M., et al., Potential impact of population-based colorectal cancer screening in Canada. <i>Chronic Diseases in Canada</i> , 2003. 24(4): p. 81-8.
6	Frazier, A.L., et al., Cost-effectiveness of screening for colorectal cancer in the general population. <i>JAMA</i> , 2000. 284(15): p. 1954-61.
7	Hassan, C., et al., Value-of-information analysis to guide future research in colorectal cancer screening. <i>Radiology</i> , 2009b. 253(3): p. 745-752.
8	Hassan, C., et al., Cost-effectiveness of early one-year colonoscopy surveillance after polypectomy. <i>Diseases of the Colon & Rectum</i> , 2009a. 52(5): p. 964-71; discussion 971.
9	Hassan, C., P.J. Pickhardt, and D.K. Rex, A resect and discard strategy would improve cost-effectiveness of colorectal cancer screening. <i>Clinical Gastroenterology & Hepatology</i> , 2010. 8(10): p. 865-9, 869.e1-3.
10	Hassan, C., et al., Colon cancer prevention in Italy: cost-effectiveness analysis with CT colonography and endoscopy. <i>Digestive & Liver Disease</i> , 2007. 39(3): p. 242-50.
11	Hassan, C., et al., Cost-effectiveness of capsule endoscopy in screening for colorectal cancer. <i>Endoscopy</i> , 2008. 40(5): p. 414-21.
12	Heitman, S.J., et al., Colorectal cancer screening for average-risk North Americans: an economic evaluation. <i>PLoS Medicine / Public Library of Science</i> , 2010. 7(11): p. e1000370.
13	Heitman, S.J., et al., Cost-effectiveness of computerized tomographic colonography versus colonoscopy for colorectal cancer screening. <i>CMAJ Canadian Medical Association Journal</i> , 2005. 173(8): p. 877-81.
14	Helm, J.F., et al., Effectiveness and economic impact of screening for colorectal cancer by mass fecal occult blood testing. <i>American Journal of Gastroenterology</i> , 2000. 95(11): p. 3250-8.
15	Heresbach, D., et al., Cost-effectiveness of colorectal cancer screening with computed tomography colonography or fecal blood tests. <i>European Journal of Gastroenterology & Hepatology</i> , 2010b. 22(11): p. 1372-9.
16	Heresbach, D., et al., Cost-effectiveness of colorectal cancer screening with computed tomography colonography according to a polyp size threshold for polypectomy. <i>European Journal of Gastroenterology & Hepatology</i> , 2010a. 22(6): p. 716-23.
17	Ho, C., et al., Computed tomographic colonography for colorectal cancer screening in an average risk population: Systematic review and economic evaluation (Structured abstract). Ottawa: Canadian Agency for Drugs and Technologies in Health (CADTH), 2008: p. 153.

18	Howard, K., et al., High participation rates are not necessary for cost-effective colorectal cancer screening. <i>Journal of Medical Screening</i> , 2005. 12(2): p. 96-102.
19	Khandker, R.K., et al., A decision model and cost-effectiveness analysis of colorectal cancer screening and surveillance guidelines for average-risk adults. <i>International Journal of Technology Assessment in Health Care</i> , 2000. 16(3): p. 799-810.
20	Knudsen, A.B., et al., Cost-effectiveness of computed tomographic colonography screening for colorectal cancer in the medicare population. <i>Journal of the National Cancer Institute</i> , 2010. 102(16): p. 1238-52.
21	Ladabaum, U. and K.A. Phillips, Colorectal cancer screening differential costs for younger versus older Americans. <i>American Journal of Preventive Medicine</i> , 2006. 30(5): p. 378-84.
22	Ladabaum, U., K. Song, and A.M. Fendrick, Colorectal neoplasia screening with virtual colonoscopy: when, at what cost, and with what national impact? <i>Clinical Gastroenterology & Hepatology</i> , 2004. 2(7): p. 554-63.
23	Lansdorp-Vogelaar, I., et al., Stool DNA testing to screen for colorectal cancer in the Medicare population: a cost-effectiveness analysis. <i>Annals of Internal Medicine</i> , 2010. 153(6): p. 368-77.
24	Lansdorp-Vogelaar, I., et al., At what costs will screening with CT colonography be competitive? A cost-effectiveness approach. <i>International Journal of Cancer</i> , 2009a. 124(5): p. 1161-8.
25	Lansdorp-Vogelaar, I., et al., Individualizing colonoscopy screening by sex and race. <i>Gastrointestinal Endoscopy</i> , 2009b. 70(1): p. 96-108, 108.e1-24.
26	Lee, D., et al., Cost Effectiveness of CT Colonography for UK NHS Colorectal Cancer Screening of Asymptomatic Adults Aged 60-69 Years. <i>Applied Health Economics and Health Policy</i> , 2010. 8(3): p. 141-54.
27	Lejeune, C., et al., Cost-effectiveness analysis of fecal occult blood screening for colorectal cancer. <i>International Journal of Technology Assessment in Health Care</i> , 2004. 20(4): p. 434-9.
28	Lejeune, C., et al., Cost-effectiveness of screening for colorectal cancer in France using a guaiac test versus an immunochemical test. <i>International Journal of Technology Assessment in Health Care</i> , 2010. 26(1): p. 40-7.
29	Loeve, F., et al., The MISCAN-COLON simulation model for the evaluation of colorectal cancer screening. <i>Computers & Biomedical Research</i> , 1999. 32(1): p. 13-33.
30	Loeve, F., et al., Endoscopic colorectal cancer screening: a cost-saving analysis. <i>Journal of the National Cancer Institute</i> , 2000. 92(7): p. 557-63.
31	Macafee, D.A.L., et al., Population screening for colorectal cancer: the implications of an ageing population. <i>British Journal of Cancer</i> , 2008. 99(12): p. 1991-2000.
32	Maciosek, M.V., et al., Colorectal cancer screening: health impact and cost effectiveness. <i>American Journal of Preventive Medicine</i> , 2006. 31(1): p. 80-9.
33	McMahon, P.M., et al., Cost-effectiveness of colorectal cancer screening. <i>Radiology</i> , 2001. 219(1): p. 44-50.
34	Ness, R.M., et al., Cost-utility of one-time colonoscopic screening for colorectal cancer at various ages. <i>American Journal of Gastroenterology</i> , 2000. 95(7): p. 1800-11.
35	O'Leary, B.A., et al., Cost-effectiveness of colorectal cancer screening: comparison of community-based flexible sigmoidoscopy with fecal occult blood testing and colonoscopy. <i>Journal of Gastroenterology & Hepatology</i> , 2004. 19(1): p. 38-47.

36	Parekh, M., A.M. Fendrick, and U. Ladabaum, As tests evolve and costs of cancer care rise: reappraising stool-based screening for colorectal neoplasia. <i>Alimentary pharmacology & therapeutics</i> , 2008. 27(8): p. 697-712.
37	Park, S.M., Y.H. Yun, and S. Kwon, Feasible economic strategies to improve screening compliance for colorectal cancer in Korea. <i>World Journal of Gastroenterology</i> , 2005. 11(11): p. 1587-93.
38	Pickhardt, P.J., et al., Small and diminutive polyps detected at screening CT colonography: a decision analysis for referral to colonoscopy. <i>AJR. American Journal of Roentgenology</i> , 2008a. 190(1): p. 136-44.
39	Pickhardt, P.J., et al., Clinical management of small (6- to 9-mm) polyps detected at screening CT colonography: a cost-effectiveness analysis. <i>AJR. American Journal of Roentgenology</i> , 2008b. 191(5): p. 1509-16.
40	Pickhardt, P.J., et al., Cost-effectiveness of colorectal cancer screening with computed tomography colonography: the impact of not reporting diminutive lesions. <i>Cancer</i> , 2007. 109(11): p. 2213-21.
41	Regge, D., et al., Impact of computer-aided detection on the cost-effectiveness of CT colonography. <i>Radiology</i> , 2009. 250(2): p. 488-497.
42	Saini, S.D., P. Schoenfeld, and S. Vijan, Surveillance colonoscopy is cost-effective for patients with adenomas who are at high risk of colorectal cancer. <i>Gastroenterology</i> , 2010. 138(7): p. 2292-9, 2299.e1.
43	Sharp, L., et al., Cost-effectiveness of population-based screening for colorectal cancer: a comparison of guaiac-based faecal occult blood testing, faecal immunochemical testing and flexible sigmoidoscopy. <i>British Journal of Cancer</i> , 2012. 106(5): p. 805-16.
44	Sobhani, I., et al., Cost-effectiveness of mass screening for colorectal cancer: choice of fecal occult blood test and screening strategy. <i>Diseases of the Colon & Rectum</i> , 2011. 54(7): p. 876-86.
45	Song, K., A.M. Fendrick, and U. Ladabaum, Fecal DNA testing compared with conventional colorectal cancer screening methods: a decision analysis. <i>Gastroenterology</i> , 2004. 126(5): p. 1270-9.
46	Sonnenberg, A. and F. Delco, Cost-effectiveness of a single colonoscopy in screening for colorectal cancer. <i>Archives of Internal Medicine</i> , 2002. 162(2): p. 163-8.
47	Sonnenberg, A., F. Delco, and P. Bauerfeind, Is virtual colonoscopy a cost-effective option to screen for colorectal cancer? <i>American Journal of Gastroenterology</i> , 1999. 94(8): p. 2268-74.
48	Sonnenberg, A., F. Delco, and J.M. Inadomi, Cost-effectiveness of colonoscopy in screening for colorectal cancer. <i>Annals of Internal Medicine</i> , 2000. 133(8): p. 573-84.
49	Stone, C.A., et al., Colorectal cancer screening in Australia: an economic evaluation of a potential biennial screening program using faecal occult blood tests. <i>Australian & New Zealand Journal of Public Health</i> , 2004. 28(3): p. 273-82.
50	Subramanian, S., G. Bobashev, and R.J. Morris, Modeling the cost-effectiveness of colorectal cancer screening: policy guidance based on patient preferences and compliance. <i>Cancer Epidemiology, Biomarkers & Prevention</i> , 2009. 18(7): p. 1971-8.
51	Tappenden, P., et al., Option appraisal of population-based colorectal cancer screening programmes in England. <i>Gut</i> , 2007. 56(5): p. 677-84.
52	Telford, J.J., et al., The cost-effectiveness of screening for colorectal cancer. <i>CMAJ Canadian Medical Association Journal</i> , 2010. 182(12): p. 1307-13.

53	Theuer, C.P., et al., Gender and race/ethnicity affect the cost-effectiveness of colorectal cancer screening. <i>Journal of the National Medical Association</i> , 2006. 98(1): p. 51-7.
54	Theuer, C.P., et al., Racial and ethnic colorectal cancer patterns affect the cost-effectiveness of colorectal cancer screening in the United States. <i>Gastroenterology</i> , 2001. 120(4): p. 848-56.
55	Tsoi, K.K.F., et al., Cost-effectiveness analysis on screening for colorectal neoplasm and management of colorectal cancer in Asia. <i>Alimentary pharmacology & therapeutics</i> , 2008. 28(3): p. 353-63.
56	van Rossum, L.G., et al., Colorectal cancer screening comparing no screening, immunochemical and guaiac fecal occult blood tests: a cost-effectiveness analysis. <i>International Journal of Cancer</i> , 2011. 128(8): p. 1908-17.
57	Vanness, D.J., et al., Comparative economic evaluation of data from the ACRIN national CT colonography trial with three cancer intervention and surveillance modeling network microsimulations. <i>Radiology</i> , 2011. 261(2): p. 487-498.
58	Vijan, S., et al., Which colon cancer screening test? A comparison of costs, effectiveness, and compliance. <i>American Journal of Medicine</i> , 2001. 111(8): p. 593-601.
59	Vijan, S., et al., The cost-effectiveness of CT colonography in screening for colorectal neoplasia. <i>American Journal of Gastroenterology</i> , 2007. 102(2): p. 380-90.
60	Wagner, J.L., Herdman, R. C., Wadhwa, S., Cost effectiveness of colorectal cancer screening in the elderly. <i>Annals of Internal Medicine</i> , 1991. 115(10): p. 8007-817.
61	Walleser, S., et al., What is the value of computerized tomography colonography in patients screening positive for fecal occult blood? A systematic review and economic evaluation. <i>Clinical Gastroenterology & Hepatology</i> , 2007. 5(12): p. 1439-46; quiz 1368.
62	Wang, Z.H., Q.Y. Gao, and J.Y. Fang, Repeat colonoscopy every 10 years or single colonoscopy for colorectal neoplasm screening in average-risk Chinese: a cost-effectiveness analysis. <i>Asian Pacific Journal of Cancer Prevention: Apjcp</i> , 2012. 13(5): p. 1761-6.
63	Whyte, S., Reappraisal of the options for colorectal cancer screening in England. <i>Colorectal Disease</i> , 2012. 14(9): p. e547-61.
64	Wilschut, J.A., et al., Fecal occult blood testing when colonoscopy capacity is limited. <i>Journal of the National Cancer Institute</i> , 2011b. 103(23): p. 1741-51.
65	Wilschut, J.A., et al., Cost-effectiveness analysis of a quantitative immunochemical test for colorectal cancer screening. <i>Gastroenterology</i> , 2011a. 141(5): p. 1648-55.e1.
66	Wong, S.S., A.P. Leong, and T.Y. Leong, Cost-effectiveness analysis of colorectal cancer screening strategies in Singapore: a dynamic decision analytic approach. <i>Medinfo</i> , 2004. MEDINFO. 11(Pt 1): p. 104-110.
67	Wu, G.H.-M., et al., Cost-effectiveness analysis of colorectal cancer screening with stool DNA testing in intermediate-incidence countries. <i>BMC Cancer</i> , 2006. 6: p. 136.
68	Zauber, A.G., Cost-effectiveness of colonoscopy. <i>Gastrointestinal Endoscopy Clinics of North America</i> , 2010. 20(4): p. 751-70.

Table A3.3.2 Excluded studies after full-text review

1	Allameh Z, Davari M, Emami MH. Cost-effectiveness analysis of colorectal cancer screening methods in Iran. <i>Archives of Iranian Medicine</i> . 2011 Mar;14(2):110-4. PubMed PMID: 21361717. English.
2	Arnesen RB, Ginnerup-Pedersen B, Poulsen PB, von Benzon E, Adamsen S, Laurberg S, et al. Cost-effectiveness of computed tomographic colonography: a prospective comparison with colonoscopy. <i>Acta Radiol</i> . 2007 Apr;48(3):259-66. PubMed PMID: 17453492. English.
3	Becker F, Nusko G, Welke J, Hahn EG, Mansmann U. Benefit-risk analysis of different risk-related surveillance schedules following colorectal polypectomy. <i>Hepatogastroenterology</i> . 2007 Dec;54(80):2249-58. PubMed PMID: 18265643. English.
4	Berchi C, Bouvier V, Reaud J-M, Launoy G. Cost-effectiveness analysis of two strategies for mass screening for colorectal cancer in France. <i>Health Economics</i> . 2004 Mar;13(3):227-38. PubMed PMID: 14981648. English.
5	Bradley CJ, Lansdorp-Vogelaar I, Yabroff KR, Dahman B, Mariotto A, Feuer EJ, et al. Productivity savings from colorectal cancer prevention and control strategies. <i>American Journal of Preventive Medicine</i> . 2011 Aug;41(2):e5-e14. PubMed PMID: 21767717. Pubmed Central PMCID: NIHMS307125 [Available on 08/01/12] PMC3139918 [Available on 08/01/12]. English.
6	Buset M, Huybrechts M. Economic impact of a colorectal cancer screening programme in Belgium. <i>Acta Gastroenterol Belg</i> . 2005 Apr-Jun;68(2):262-3. PubMed PMID: 16013647. English.
7	Cahill BA. Colorectal cancer. Which test is best? <i>Advance for Nurse Practitioners</i> . 2005 Jan;13(1):71-4. PubMed PMID: 15679298. English.
8	Canadian COHTA. Economic evaluation of population-based screening for colorectal cancer (Brief record). Ottawa: Canadian Coordinating Office for Health Technology Assessment (CCOHTA). 2002.
9	Chen L-S, Liao C-S, Chang S-H, Lai H-C, Chen TH-H. Cost-effectiveness analysis for determining optimal cut-off of immunochemical faecal occult blood test for population-based colorectal cancer screening (KCIS 16). <i>Journal of Medical Screening</i> . 2007;14(4):191-9. PubMed PMID: 18078564. English.
10	Chiu SYH, Malila N, Yen AMF, Anttila A, Hakama M, Chen HH. Analytical decision model for sample size and effectiveness projections for use in planning a population-based randomized controlled trial of colorectal cancer screening. <i>Journal of Evaluation in Clinical Practice</i> . 2011 Feb;17(1):123-9. PubMed PMID: 20831662. English.
11	Church JM. Colon cancer screening update and management of the malignant polyp. <i>Clin</i> . 2005 Aug;18(3):141-9. PubMed PMID: 20011297. Pubmed Central PMCID: PMC2780100. English.
12	Delco F, Sonnenberg A. At what age should a one-time only colonoscopy for screening of colorectal cancer be performed? <i>Eur J Gastroenterol Hepatol</i> . 1999 Nov;11(11):1319-20. PubMed PMID: 10563547. English.
13	Delco F, Sonnenberg A. Limitations of the faecal occult blood test in screening for colorectal cancer. <i>Ital J Gastroenterol</i> . 1999 Mar;31(2):119-26. PubMed PMID: 10363196. English.
14	Fisher JA, Fikry C, Troxel AB. Cutting cost and increasing access to colorectal cancer screening: another approach to following the guidelines. <i>Cancer Epidemiol Biomarkers Prev</i> . 2006 Jan;15(1):108-13. PubMed PMID: 16434595. English.
15	Frew E, Wolstenholme JL, Whyntes DK. Willingness-to-pay for colorectal cancer screening. <i>European Journal of Cancer</i> . 2001 Sep;37(14):1746-51. PubMed PMID: 11549427. English.

16	Grazzini G, Ciatto S, Cislacchi C, Castiglione G, Falcone M, Mantellini P, et al. Cost evaluation in a colorectal cancer screening programme by faecal occult blood test in the District of Florence. <i>Journal of Medical Screening</i> . 2008;15(4):175-81. PubMed PMID: 19106257. English.
17	Griffith S, Kane KY. What is the most cost-effective screening regimen for colon cancer? <i>J</i> . 2001 Jan;50(1):13. PubMed PMID: 11195472. English.
18	Hassan C, Pickhardt PJ, Di Giulio E, Hunink MGM, Zullo A, Nardelli BB. Value-of-information analysis to guide future research in the management of the colorectal malignant polyp. <i>Dis Colon Rectum</i> . 2010 Feb;53(2):135-42. PubMed PMID: 20087087. English.
19	Haug U, Brenner H. A simulation model for colorectal cancer screening: potential of stool tests with various performance characteristics compared with screening colonoscopy. <i>Cancer Epidemiol Biomarkers Prev</i> . 2005 Feb;14(2):422-8. PubMed PMID: 15734968. English.
20	Henry SG, Ness RM, Stiles RA, Shintani AK, Dittus RS. A cost analysis of colonoscopy using microcosting and time-and-motion techniques. <i>Journal of General Internal Medicine</i> . 2007 Oct;22(10):1415-21. PubMed PMID: 17665271. Pubmed Central PMCID: PMC2305858. English.
21	Inadomi JM, Sonnenberg A. The impact of colorectal cancer screening on life expectancy. <i>Gastrointestinal Endoscopy</i> . 2000 May;51(5):517-23. PubMed PMID: 10805834. English.
22	Ladabaum U, Ferrandez A, Lanas A. Cost-effectiveness of colorectal cancer screening in high-risk Spanish patients: use of a validated model to inform public policy. <i>Cancer Epidemiol Biomarkers Prev</i> . 2010 Nov;19(11):2765-76. PubMed PMID: 20810603. Pubmed Central PMCID: NIHMS311762 PMC3159034. English.
23	Lejeune C, Arveux P, Dancourt V, Fagnani F, Bonithon-Kopp C, Faivre J. A simulation model for evaluating the medical and economic outcomes of screening strategies for colorectal cancer. <i>Eur J Cancer Prev</i> . 2003 Feb;12(1):77-84. PubMed PMID: 12548114. English.
24	Li S, Wang H, Hu J, Li N, Liu Y, Wu Z, et al. New immunochemical fecal occult blood test with two-consecutive stool sample testing is a cost-effective approach for colon cancer screening: results of a prospective multicenter study in Chinese patients. <i>International Journal of Cancer</i> . 2006 Jun 15;118(12):3078-83. PubMed PMID: 16425283. English.
25	Lieberman D. Cost-effectiveness of colonoscopy in screening for colorectal cancer; cost-effectiveness of screening colorectal cancer in the general population. <i>Gastrointestinal Endoscopy</i> . 2001 Oct;54(4):537-8. PubMed PMID: 11601425. English.
26	Lucidarme O, Cadi M, Berger G, Taieb J, Poynard T, Grenier P, et al. Cost-effectiveness modeling of colorectal cancer: computed tomography colonography vs colonoscopy or fecal occult blood tests. <i>Eur J Radiol</i> . 2012 Jul;81(7):1413-9. PubMed PMID: 21444171. English.
27	McGrath JS, Ponich TP, Gregor JC. Screening for colorectal cancer: the cost to find an advanced adenoma. <i>American Journal of Gastroenterology</i> . 2002 Nov;97(11):2902-7. PubMed PMID: 12425566. English.
28	Provenzale D. Cost-effectiveness of screening the average-risk population for colorectal cancer. <i>Gastrointestinal Endoscopy Clinics of North America</i> . 2002 Jan;12(1):93-109. PubMed PMID: 11916165. English.
29	Sekiguchi M, Matsuda T, Tamai N, Sakamoto T, Nakajima T, Otake Y, et al. Cost-effectiveness of total colonoscopy in screening of colorectal cancer in Japan. <i>Gastroenterol Res Pract</i> . 2012;2012:728454. PubMed PMID: 22291697. Pubmed Central PMCID: PMC3265074. English.

30	Sharara N, Adam V, Crott R, Barkun AN. The costs of colonoscopy in a Canadian hospital using a microcosting approach. <i>Canadian Journal of Gastroenterology</i> . 2008 Jun;22(6):565-70. PubMed PMID: 18560635. Pubmed Central PMCID: PMC2660815. English.
31	Sieg A, Brenner H. Cost-saving analysis of screening colonoscopy in Germany. <i>Zeitschrift fur Gastroenterologie</i> . 2007 Sep;45(9):945-51. PubMed PMID: 17874356. English.
32	Sonnenberg A. Cost-effectiveness in the prevention of colorectal cancer. <i>Gastroenterol Clin North Am</i> . 2002 Dec;31(4):1069-91. PubMed PMID: 12489279. English.
33	Sorrentino D, Paduano R, Bernardis V, Piccolo A, Bartoli E. Colorectal cancer screening in Italy: feasibility and cost-effectiveness in a model area. <i>Eur J Gastroenterol Hepatol</i> . 1999 Jun;11(6):655-60. PubMed PMID: 10418938. English.
34	Subramanian S, Bobashev G, Morris RJ. When budgets are tight, there are better options than colonoscopies for colorectal cancer screening. <i>Health Affairs</i> . 2010 Sep;29(9):1734-40. PubMed PMID: 20671020. English.
35	Sweet A, Lee D, Gairy K, Phiri D, Reason T, Lock K. The impact of CT colonography for colorectal cancer screening on the UK NHS: costs, healthcare resources and health outcomes. <i>Appl Health Econ Health Policy</i> . 2011;9(1):51-64. PubMed PMID: 21174482. English.
36	van Ballegooijen M, Rutter CM, Knudsen AB, Zauber AG, Savarino JE, Lansdorp-Vogelaar I, et al. Clarifying differences in natural history between models of screening: the case of colorectal cancer. <i>Med Decis Making</i> . 2011 Jul-Aug;31(4):540-9. PubMed PMID: 21673187. English.
37	Ventura L, Zappa M, Carreras G, Ciatto S, Grazzini G. What is the best screening strategy to detect advanced colorectal adenomas? Simulation from ongoing Italian screening experiences. <i>Tumori</i> . 2011 Sep-Oct;97(5):547-50. PubMed PMID: 22158481. English.
38	Vijan S, Inadomi J, Hayward RA, Hofer TP, Fendrick AM. Projections of demand and capacity for colonoscopy related to increasing rates of colorectal cancer screening in the United States. <i>Aliment Pharmacol Ther</i> . 2004 Sep 1;20(5):507-15. PubMed PMID: 15339322. English.
39	Whynes DK. Cost-effectiveness of faecal occult blood screening for colorectal cancer: results of the Nottingham trial. <i>Crit Rev Oncol Hematol</i> . 1999 Nov;32(2):155-65. PubMed PMID: 10612015. English.
40	Whynes DK, Nottingham FOBST. Cost-effectiveness of screening for colorectal cancer: evidence from the Nottingham faecal occult blood trial. <i>Journal of Medical Screening</i> . 2004;11(1):11-5. PubMed PMID: 15006108. English.
41	Wohl P, Bednarik M, Wohl P, Cervenka M, Spicak J. Comparison of various strategies for colorectal cancer screening tests. <i>Eur J Gastroenterol Hepatol</i> . 2011 Nov;23(12):1157-64. PubMed PMID: 21989120. English.
42	Zauber AG, Lansdorp-Vogelaar I, Knudsen AB, Wilschut J, van Ballegooijen M, Kuntz KM. Evaluating test strategies for colorectal cancer screening: a decision analysis for the U.S. Preventive Services Task Force. <i>Annals of Internal Medicine</i> . 2008 4 Nov;149(9):659-69. PubMed PMID: 18838717. English.

Table A3.4 Summary of included studies

Table A3.4 Summary of included studies					
Author	Perspective	Population	Intervention(s)	Comparators	Reported results
Chauvin (2012)	3rd party payer	50 - 80yrs average risk people, France	CTCq5Y (every 5 year) CTCq10Y	Immunological FOBTq2Y	Close expected net benefits between iFOBT and CTCq5 induced uncertainty in the choice of the optimal strategy. PSA then suggested that below a WTP per LYG of 8,587€/LYG, CTCq10Y was optimal, while CTCq5Y would be preferred beyond a WTP of 8,587€/LYG.
Dan (2012)	Societal	50-75 yrs individuals, Singapore	SIG once iFOBTq1Y BEq5Y COL once SIGq5Y SIGq5Y + iFOBTq1Y Stool DNAq5Y COLq10Y CTCq5Y iFOBT + COLq10Y	No screening	Performing single SIG at 60yrs was the cheapest screening strategy; Screening subjects 50 to 60 yrs old by iFOBT and subjects 60 to 72 yrs old with COL q10Y was the most CE strategy (USD \$25,000/QALY).
Hassan (2010)	Societal	Average risk 50yrs Population in the US	NBI with resect and discard policy using q10Y	COLq10Y no screening	With universal referral of resected polyps to pathology, COL screening costs an estimated \$3222/person, with a gain of 51 days/person
Heitman (2010)	Publicly funded health care system	50-75yrs age-two stratified groups (50-64yrs, 65-75yrs) Average risk population, Canada	FOBTq1Y (low- high-) FITq1Y(3 strategies-low, mid, high test performance) Fecal DNAq3Y FSIGq5Y CTCq5Y COLq10Y	No screening compared to each modality	FIT1q1Y, assuming mid-range testing characteristics, was more effective and less costly compared to all strategies (including no screening) except FIT-high. Among the lifetimes of 100,000 average-risk patients, the number of CRC could be reduced from 4,857 to 1,782 and the number of CRC deaths from 1,393 to 457, while saving Canadian \$68 per person.

Table A3.4 Summary of included studies

Author	Perspective	Population	Intervention(s)	Comparators	Reported results
Heitman (2005)	To inform Canadian Health policy decision makers	50 years, Canada	CTC then COL for adenomas 6mm or larger	COL	CTC for CRC screening would cost \$2.27mil extra per 100 000 patients screened; 3.78 perforation-related deaths would be avoided, but 4.11 extra deaths would occur from missed adenomas. Because CTC screening would cost more and result in more deaths overall compared with COL, the latter remained the dominant strategy. Our results were sensitive to CTC test performance characteristics, the malignant risk of missed adenomas, the risk of perforation and related death, the procedural costs and differences in screening adherence.
Heresbach (2010b)	3 rd party payer, only direct costs	Average risk 50-74 years, follow up model considered people with adenoma, France	gFOBTq2Y	iFOBTq2Y CTCq10Y	Using CTC requires substantially less COL than iFOBT and is CE for low values of WTP(less than 20000/LYG). However, iFOBT is the preferred screening strategy for a WTP greater than 6207euro/LYG.

Table A3.4 Summary of included studies

Author	Perspective	Population	Intervention(s)	Comparators	Reported results
Ho (2008)	Publicly funded health care system	Average-risk Canadians aged 50-74yrs	CTCq10Y	COLq10 FOBTq1Y No screening	When compared to no screening using a cost-effectiveness framework, COL, FOBT and CTC were associated with incremental gains in quality-adjusted life expectancy (0.04, 0.02, and 0.03 additional QALY, respectively). In the base-case, the no screening strategy was the least expensive, followed by FOBT and then COL. CTC was associated with worse clinical outcomes and higher costs than COL. Compared to no screening COL was associated with a cost per QALY gained of \$7,937. In PSA, compared to no screening, COL is associated with a cost per QALY of less than \$10,000 nearly 99% of the time, while COL is cost saving by comparison to CTC 91% of the time.
Khandker (2000)	Payer's perspective	50yrs and older without predisposing factors (screening 50-85yrs), US	1) annual FOBT 2) FSIGq3Y 3) FSIGq5Y 4) annual FOBT and FSIGq5Y 5) DCBEq5Y 6) COLq5Y 7) COLq10Y	No screening	Lifetime costs of CRC \$643 per person with no screening, compared to \$2058 (annual FOBT), \$2079 (FSIGq3Y), \$1713 (FSIG q5Y), \$2854 (FOBT annual and FSIGq3Y), \$2639 (annual FOBT and FSIGq5Y), \$2577 (DCBEq5Y), \$3906 (COLq5), \$2602 (COLq10). SIGq5Y and annual FOBT were the most cost-effective strategies; FOBT was less cost-effective when the compliance is low.
Lee (2010)	NHS	Average risk 60-69yrs CRC screening, UK	CTC	FOBT FSIG COL	CRCq10Y was cost-effective compared to biennial FOBT.

Table A3.4 Summary of included studies

Author	Perspective	Population	Intervention(s)	Comparators	Reported results
Lejeune (2004)	French health-care insurance system	Individuals until 85, France	FOBT (Hemoccult-II test)q2Y 50-74yrs	No screening	Modelling biennial screening vs the absence of screening over a 20-year period resulted in a 17.7% mortality reduction and a discounted incremental cost-effectiveness ratio of €3,357 per life-years gained among individuals 50-74 years of age. Sensitivity analyses performed on epidemiological and economic data showed the strong impact on the results of colonoscopy cost, of compliance to screening and of specificity of the screening test.
Lejeune (2010)	Possibly French health-care insurance system	Individuals aged 50 to 74 (screening offered) and followed until 85yrs or death, France	gFOBTq2Y	iFOBT No screening	Compared to no screening, gFOBT and iFOBT were associated with a decrease in colorectal cancer mortality of 17.4% and 25.2%, respectively. With regard to cost-effectiveness, expressed as cost per life-years gained, iFOBT was the most effective and most costly alternative. Compared to no screening, gFOBT and iFOBT presented similar discounted incremental cost-effectiveness ratios: €2739 and €2819 respectively per LYG. When compared to gFOBT, iFOBT presented an ICER of 2988 per LYG.
Loeve (1999)	Not specified	50yrs olds, US	Planned intervention(s) for economic evaluation: FSIGq3Y (till 74yrs) unhydrated FOBTq2Y (till 80yrs)	No screening	All kinds of assumptions on the natural history of CRC and screening and surveillance strategies can easily be incorporated in the model. MISCAN-COLON gives detailed output of incidence, prevalence and mortality, and the results and effects of screening. It can be used to test hypotheses about the natural history of colorectal cancer, such as the duration of progressive adenomas, and screening characteristics, such as sensitivity of test, against empirical data.

Table A3.4 Summary of included studies

Author	Perspective	Population	Intervention(s)	Comparators	Reported results
Loeve (2000)		50yrs olds, US	FSIGq3Y (till 74yrs) unhydrated FOBTq2Y (till 80yrs)	No screening	Given the expert opinion-based assumptions, a program based on q5Y SIG screenings could result in a net savings of direct health care costs due to prevention of cancer treatment costs that compensate for the costs of screening, diagnostic follow-up, and surveillance. This result persists when costs and health effects are discounted at 3%. The 'break-even' point, the time required for a screening program that terminates after 30 years and 44 years for a screening program that continues on indefinitely. However, net savings increase assumptions about natural history of CRC, costs of screening, surveillance, and diagnostics are considered.
Lansdorp-Vogelaar (2009a)	Not stated (maybe 3rd party payer perspective)	50-80yrs general population	CTC with 20Y, 15Y, 10Y, 5Y intervals (1) intensive referral: any suspected polyps (2) intermediate referral: suspected polyp \geq 6mm (3) minimal referral: suspected polyp \geq 10mm	COL q20Y COLq15Y COLq10Y COLq5Y	With equal costs (\$662), COL dominated CTC screening. For CTC to gain similar LGY as COL q10Y, it should be offered q5Y with referral of polyps \geq 6mm.
Eddy (1990)	Not stated	50yr persons at average risk and persons at high risk (having a 1st degree relative with CRC), US	FOBT (Hemoccult-II)q1Y plus ACBEq3Y FOBTq1Y plus 60cm FSIGq5Y FOBTq1Y plus COLq5Y FOBTq1Y plus ACBEq1Y FOBTq1Y plus COLq3Y FOBTq1Y plus COLq1Y	No screening	Screening persons for 25 years, from the age of 50 to the age of 75yrs should reduce the chance of developing or dying from CRC by 10% to 75%, depending on which screening tests are used and how often screening is done.

Table A3.4 Summary of included studies

Author	Perspective	Population	Intervention(s)	Comparators	Reported results
Lansdorp-Vogelaar (2010)	3rd party payer	65yrs olds (varied, aged to 50 in sensitivity analysis)	Stool DNAq3Y Stool DNAq5Y	No screening HII; HS iFOBT SIGB; SIG HII + SIGB HII + SIG HS + SIGB HS + SIG HSq3Y + SIGB HSq3Y + SIG iFOBT + SIGB iFOBT + SIG iFOBTq3Y + SIGB iFOBTq3Y + SIG; COL	Assuming a cost of \$350 per test, strategies of stool DNA testing q3Y or q5Y yielded fewer life years and higher costs than the currently recommended CRC screening strategies. Screening with the stool DNA test would be cost-effective at a per-test cost of \$40 to \$60 for stool DNA testing q3Y, depending on the simulation model used. There were no levels of sensitivity and specificity for which stool DNA testing would be cost-effective at its current cost of \$350 per test. Stool DNA testing q3Y would be cost-effective at a cost of \$350 per test if the relative adherence to stool DNA testing were at least 50% better than that with other screening tests.
McMahon (2001)	re-analysis of existing studies (Eddy 1990, Glick 1998, OTA 1995)	US	FOBT (Hemoccult-II)q1Y plus ACBEq3Y FOBTq1Y plus 60cm FSIGq5Y FOBTq1Y plus COLq5Y FOBq1Y plus ACBEq1Y FOBTq1Y plus COLq3Y FOBTq1Y plus COLq1Y	No screening	Strategies in which DCBE examination was performed emerged as optimal from all studies included. In average-risk individuals, screening with DCBE examination q3Y or q5Y with annual FOBT, had an ICER of less than \$55,600 per life-years saved. However DCBE examination screening q3Y plus annual FOBT had an ICER of more than \$100,000 per life-years saved. COL had an ICER of more than \$100,000 per life years saved, was dominated by other screening strategies and offered less benefit than did DCBE.

Table A3.4 Summary of included studies

Author	Perspective	Population	Intervention(s)	Comparators	Reported results
Ness (2000)	Societal perspective	40 year old men and women in the US	One-time COL at; 45-49yrs 50-54 55-59 60-64	No screening	It was determined that one-time COL screening in men age 60yr and in women age <65yr dominated never screening and screening at older ages. For both sexes, one-time COL screening between 50 and 54yrs was associated with a marginal cost-utility of less than \$10,000 per QALY compared to screening between 55 and 60yrs of age. One-time COL screening between 45 and 49yrs of age was either dominated (women) or associated with a marginal cost-utility of \$69,000/QALY (men) compared to screening between 50 and 54yr of age. The marginal cost-utility of one-time COL screening was relatively insensitive to plausible changes in the cost of COL, the cost of CRC treatment, the sensitivity of COL for colorectal neoplasia, the utility values representing the morbidity associated with the CRC-related health states and the discount rate.
Pickhardt (2008a)	Not stated	60yrs asymptomatic polyps; diminutive ($\leq 5\text{mm}$), small (6-9mm), large ($\geq 10\text{mm}$), US	CTC then COL	CTC only	Estimated 10Y CRC risk for unresected diminutive (0.08%), small (0.7%) and large polyps (15.7%). ICER of removing all diminutive \$465,407 and small CTC-detected polyps \$59,015 per life-years gained. Polypectomy for large CTC-detected polyps yielded a cost-saving of \$151 per person screened.
Pickhardt (2008b)	not stated	60yrs asymptomatic people with small polyps (6- to 9-mm) detected at CTC screening, US	CTCq3Y surveillance	Immediate polypectomy	Without any intervention, the estimated 5-year CRC death rate from 6- to 9-mm polyps in this concentrated cohort was 0.08%, which is a sevenfold decrease over the 0.56% CRC risk for the general unselected screening population. The death rate was further reduced to 0.03% with the CTC surveillance strategy and to 0.02% with immediate colonoscopy referral. However, for each additional cancer-related death prevented with immediate polypectomy versus CTC follow-up, 9,977 COL referrals would be needed, resulting in 10 additional perforations and an incremental cost-effectiveness ratio of \$372,853.

Table A3.4 Summary of included studies

Author	Perspective	Population	Intervention(s)	Comparators	Reported results
Saini (2010)	Not stated	50yrs with newly diagnosed adenomas surveillance COL until 85yrs, US	COLq3Y HR, q10Y LR (3/10) 3/5 3/3	No surveillance	3/5 USD5743/QALY gained compared with no surveillance, 3/3 strategy was dominated by 3/5 strategy. Assuming that the probability of advanced adenoma formation was 1.3% per year (based 0.5%), the incremental cost-effectiveness ratio (ICER) of the 3/5 strategy was <50000/QALY gained if the relative ratio of advanced adenoma formation was <2.4 (base 3.9).
Sharp (2012)	A healthcare payer perspective, Health Service Executive	55-74yrs, Ireland	1) gFOBYq2Y 55-74yrs, with reflex FIT 2) FITq2Y 55-74yrs 3) FSIG once-only at 60yrs	No screening	All scenarios would be considered highly cost-effective compared to no screening. The lowest ICER vs no screening (ICER vs no screening €589 per QALY gained) was found for FSIG, followed by FIT (€1696) and gFOBT (€4428); gFOBT was dominated. Compared with FSIG, FIT was associated with greater gains in QALYs and reductions in lifetime cancer incidence and mortality, but was more costly, required considerably more COL and resulted in more complications.
Song (2004)	Not stated; "indirect costs were not included" & "aimed to explore the potential role of F-DNA in a national strategy"	50-80yrs average risk of developing CRC, US	F-DNAq5Y COLq10Y FOBTq1Y FSIGq5Y FOBT combined with FSIG	No screening	Compared with no screening fDNA at a screening interval of 5Y decreased CRC incidence by 35% and CRC mortality by 54% and gained 4560 life-years per 100,000 persons at 47,700/LYG in the base-case. However, fDNA gained fewer LY and was more costly than conventional screening. The average number of COL per person was 3.8 with COL strategy and 0.8 with fDNA strategy. In most 1-way SA and Monte Carlo simulation iterations, fDNA remained reasonably cost-effective compared with no screening, but COL and FOBT dominated fDNA. Assuming fDNA testing sensitivities of 65% for CRC and 40% for large polyp, and 95% specificity, a screening interval of 2Y and a test cost of \$195 would be required to make fDNA comparable with COL.

Table A3.4 Summary of included studies

Author	Perspective	Population	Intervention(s)	Comparators	Reported results
Parekh (2008)	Not stated	US	FecalDNAq3Y FOBTq1Y iFOBT COLq10Y		FOBT and iFOBT life-years gained (LYG) per person and cost less than no screening. Fecal DNA testing version 1.1 at \$300 (the current PreGen Plus test) gained 5323 LYG/100 000 persons at \$16 900/LYG and fecal DNA testing version 2 (enhanced test) gained 5795 LYG/100 000 persons at \$15 700/LYG vs no screening. In the base-case and most sensitivity analyses, FOBY and faecal immunochemical testing were preferred to faecal DNA testing. Faecal DNA testing version 2 cost \$100 000/LYG vs faecal immunochemical testing when per-cycle adherence with faecal immunochemical testing was 22%. Faecal immunochemical testing with excellence adherence was superior to COL every 10Y.
Ladabaum (2004)	National perspective	Average risked US population 50yrs for 50 yrs time horizon	CTCq10Y (test performance reported by Cotton <i>et al</i>) CTCq10Y (base-case) CTCq10Y(with test performance as reported by Pickhardt(2003)	No screening COL	In the best case considered (95%, 94%, and 87% sensitivity for CRC, polyps≥10mm, and polyps <10mm), CTC was nearly as effective as COL. However, if test costs were equal, total cost per person was 15% greater for CTC than COL, making COL dominant. When test cost for CTC was ≤60% of test cost for COL, the small benefit of COL vs CTC cost >\$200,000/incremental life-year. The greater the likelihood of being referred for COL after CTC, the greater the advantage of COL. with 75% screening adherence in the US, CTC and COL could decrease CRC incidence by 46%-54%, with COL requiring 6.9 million COL/year, and CTC, 3.2million COL/year, plus 5.4million CTC/year with CTC.
Ladabaum (2006)	not stated	US			As screening uptake increased, CRC incidence and mortality decreased, and annual costs related to CRC care and testing increased for younger persons, but decreased for older persons. Compared with current screening uptake of 40%, screening 75% of the US population aged 50 to 80 increased annual costs related to CRC care and testing from \$3.5 billion to \$5.0 billion for 50 to 64 years old, but decreased annual costs form \$5.9 billion to \$5.6 billion for those aged 65 years and older. Sensitivity analyses suggest that future costs for other diseases could offset CRC care savings in older Americans that are attributable to screening.

Table A3.4 Summary of included studies

Author	Perspective	Population	Intervention(s)	Comparators	Reported results
					However, even without net cost savings for any age group, screening remained relatively cost-effective.
Sonnenberg (2000)	3rd party payer	50yrs old general population, annual cycle till death, US	FOBTq1Y FSIGq5Y COLq10Y	No screening	Compared to COL, FOBTq1Y costs less but saves fewer life-years. A screening strategy based on FSIG q5Y or 10Y was less cost-effective than the other two screening methods.
Tappenden (2007)	NHS	50yrs and older, UK	(1) FOBT biennial 50-69yrs (2) FOBT biennial 60-69yrs (3) FSIG once at 55yrs (4)FSIG once at 60yrs (5) FSIG once at 60yrs, followed by FOBT 61-70yrs	No screening	FSIG with or without FOBT may be cost-saving and may produce additional benefits compared with no screening. The marginal cost-effectiveness of FOBT options compared to no screening is estimated to be below GBP3000 per QALY gained.
Wagner (1991)	Not stated	65yrs old individuals until 85yrs or death, US	1)FOBTq1Y and SIGq3Y 2)FOBTq2Y and SIGq5Y 3)FOBTq1Y and SIG at 65yrs 4)FOBT	No screening	A program of annual FOBT in the elderly would detect at least 17% of the expected cases of cancer and could cost \$35 000 per year of life saved. Screening schedules that include periodic SIG would prevent more cases of cancer but could cost between \$43 000 and \$47 000 per year of life gained. These estimates are based on uncertain assumptions, but results were not extremely sensitive to further relaxation of the values of the most uncertain assumptions.

Table A3.4 Summary of included studies

Author	Perspective	Population	Intervention(s)	Comparators	Reported results
Theuer (2008)	Not stated	50yr old Black, Latinos, Asians and white men and women, US	Annual FOBT plus FSIGq5Y	COLq10Y	Age-specific CRC incidence rates were highest in black men and lowest in Latino women. Screening beginning at age 50 was most cost-effective in black men and least cost-effective in Latino women (measured in USD/LYS) using annual FOBT testing combined with FSIGq5Y and using COLq10Y. The cost-effectiveness of a 35-yr screening program in black men beginning at age 45 was similar to the cost-effectiveness of screening white men and black women beginning at age 50 and more cost-effective than screening nonblack women as well as Asian and Latino men beginning at age 50.
Theuer (2001)	Not stated	50yr old, US	Annual FOBT plus SFIGq5Y	COLq10Y	Average annual age-specific CRC incidence rates were highest in blacks and lowest in Latinos.
Vijan (2001)	3 rd party payer (listed as one of limitations)	50yrs, US	Once- lifetime COL Twice-lifetime COL	FOBT FOBT+FSIG FSIG COL	With 100% compliance rate, twice-lifetime COL at 50yrs and 60yrs and FSIG with FOBT are most effective. Comp with primary screening tests and follow-up for polyps affect screening decisions. COL at 50 and 60yrs was the preferred test regardless of compliance with the primary screening test. However, if FU COL for polyps is less than 75%, then even once-lifetime COL was preferred over most combinations of FSIG and FOBT.
Maciosek (2006)	Not stated	Average-risk 50yrs and older, US	FOBTq1Y FSIGq5Y COLq10Y		If a birth cohort of 4 million were offered screening at recommended intervals, 31,500 deaths would be prevented and 338,000 years of life would be gained over the lifetime of the birth cohort. In the current cross-section of people aged 50 and older, 18,800 deaths could be prevented each year by offering all people in this group screening at recommended intervals. Only 58% of these deaths are currently being prevented. In year 2000 dollars, the cost effectiveness of offering patients aged 50 and older a choice of colorectal cancer screening options is \$11,900 per year of life gained.

Table A3.4 Summary of included studies

Author	Perspective	Population	Intervention(s)	Comparators	Reported results
Vijan (2007)	Not stated	50yrs till 80yrs (screening), modelled till 100yrs, US	2D CTC q5Y+COL 2D CTC q10Y+COL 3D CTC q5Y+COL 3D CTC q10Y+COL	No screening current practice (FOBT, COL, FSIG)	COL dominates 2D CTC q5Y or q10Y. COL is weakly dominant over 3D CTC q5Y or q10Y. 3D CTC q5Y is more effective than COL q10Y, but costs an incremental \$156000 per LYG. SA showed that 3D CTC q5Y is a dominant strategy of COL costs 1.6times more than CTC. COL is a dominant strategy if the sensitivity of CTC for 1cn adenomas is 83% or lower.
Walleser (2007)	Government perspective, Australia	People with a positive FOBT	CTC	COL	CTC is less effective and more costly than COL; if CTC was more sensitive than COL, CTC was more effective, at higher cost.
Wu (2008)	3 rd party payer perspective	general population 50-75y, Taiwan	Stool DNAq3Y Stool DNAq5Y Stool DNAq10Y	No screening FOBYq1Y FSIGq5Y COLq10Y	Stool DNA testing every 3,5 and 10 years can reduce CRC mortality by 22%, 15%, and 9%, respectively. The associated incremental costs were \$9,794, \$9,335, and \$7,717, per life-years saved when compared with no screening. Stool DNA testing strategies were the least cost-effective with the cost per stool DNA test, referral rate with diagnostic COL, prevalence of large adenoma, and the discount rate being the most influential parameters.
Zauber (2010)	Centre for Medicare and Medicaid Services (CMS) perspective on CTC	US population 65y-85y (50y in sensitivity analysis)	14) CTC DoD 15) CTC ACRIN	1) Nothing 2) Hemoccult II(HII) 3) Hemoccult SENSE (HS) 4) FIT 5) SIGbiopsy 6)SIG 7) HII + SIGb 8) HII + SIG 9) HS + SIGb 10) HS + SIG 11) FIT + SIGb	Annual high sensitive FOBTs (guaiac and FIT), FSIGq5Y with sensitive FOBTq1Y, and COL were reasonably cost-effective strategies for CRC. Hemoccult II only and FSIG only were not included in this set of acceptable tests. Similarly, with current levels of test costs based on diagnostic procedures, CTC was not a cost-effective choice.

Table A3.4 Summary of included studies

Author	Perspective	Population	Intervention(s)	Comparators	Reported results
				12) FIT + SIG 13) COL	
Knudsen (2010)	Payer's perspective (CMS and modified societal excluding productivity cost)	Average risked 65yr old individuals, US	CTC DoDq5Y CTC NCTCq5Y	1)H-IIq1Y 2)Hemoccult SENA (HS) q1Y 3)iFOBTq1Y 4)SIGq5Y 5)SIGBiopsyq 5Y 6) 1) + 4) 7) 1) + 5) 8) 2) + 4) 9) 2)+ 5) 10) 3) + 4) 11) 3) + 5) 12)COLq10Y 13)no screening	Assuming perfect adherence with all tests, the undiscounted number of life-years gained from CTC screening ranged from 143 to 178 per 1000 65yr olds, which was slightly less than the number of life-years gained from 10-yearly COL (152-185 per 1000 65 yr-olds) and comparable to that from 5-yearly SIG with annual FOBT (149-177 per 1000 65yrs-olds). If CTC screening was reimbursed at \$488 per scan (slightly less than the reimbursement for a COL without polypectomy), it would be the most costly strategy. CTC screening could be cost-effective at \$108-\$205 per scan, depending on the microsimulation model used. Sensitivity analyses showed that if relative adherence to CTC screening was 25% higher than adherence to other tests, it could be cost-effective if reimbursed at \$488 per scan.
Vanness (2011)	US health sector perspective	Average risk asymptomatic 50yrs olds (screened until 80yrs & simulated to death) in the US	FOBTq1Y + FISGq5Y FITq1Y + FSIGq5Y COLq10Y CTqC5Y (5 mm referral threshold) CTCq10Y (5 mm referral threshold) Each strategy was run through the colorectal cancer Simulated population model for Incidence and Natural history (CRC-SPIN),		CTC at 5- and 10-year intervals was more costly and less effective than FOBT plus FSIB in all three models in both the 100% and 50% adherence scenarios. COL also was more costly and less effective than FOBT plus FSIG, except in the CRC-SPIN model assuming 100% adherence (ICER \$26,300/LYG). CTC at 5- and 10-year screening intervals and COL were net beneficial over the 10-year interval except in the MISCAN model when assuming 100% adherence and WTP \$50,000/LYG.

Table A3.4 Summary of included studies

Author	Perspective	Population	Intervention(s)	Comparators	Reported results
			MISCAN, SimCRC models		
Subramanian (2009)	3rd party payer, only direct medical costs	Average risk 50yrs, screening to 80yrs preference (pref) and compliance (comp) incorporated, US	FOBTq5Y FOBTq10Y FSIGq5Y FSGIq10Y COLq5Y COLq10Y comp at 45% (scenario 1)	No CRC screening (2) Scenario (3) 45% comp with 35% population never been screened Scenario (4) 100% comp	Improved comp is positively related to the reduction of CRC mortality. Achieving higher levels of compliance with screening or diagnosis recommendations such as targeted education and use of navigators to assist patients to increase adherence.
Macafee (2008)	Not specifically stated but top-down costs (direct costs) were considered	60yr olds, modelled for 50yrs for two timescale: 2003 (early cohort) and 2033 (late cohort), UK	Unhydrated FOBT q2Y 60-69yrs (2003 cohort) unhydrated FOBT q2Y 60-69yrs (2033 cohort)	No screening compared with corresponding cohort (early or late)	Life expectancy was assumed to increase by 2.5 years per decade. There were 407 552 fewer people entering the model in the 2033 model due to a lower birth cohort, and population screening saw 30 345 fewer CRC-related deaths over the 50 years of the model. Screening the 2033 cohort would cost £96 million with cost savings of £43 million in terms of detection and treatment and 28 million GBP in palliative care costs. After 30 years of follow-up, the cost per life year saved was £1544. An identical screening programme in an early cohort (2003) saw a cost per life year saved of £1651.

Table A3.4 Summary of included studies

Author	Perspective	Population	Intervention(s)	Comparators	Reported results
Telford (2010)	3 rd party paper	50yrs average risk screening and surveillance until 75yrs old, Canada	gFOBT low sensitivity (Se) q2Y gFOBT low Se q1Y gFOBT high Se 1Y gFOBT low Se q1Y plus SIGq5Y FITq1Y Fecal DNAq1Y DCBEq5Y CTCq5Y COLq10Y	No screening	current strategies reduced CRC incidence and mortality compared with no screening ICER CAD \$9159 (gFOBT low Se q1Y), CAD \$611(FITq1Y), CAD \$6133 (COLq10Y)
Di Bidino (2010)	HC system perspective	Average risk, Italy	Arm 1 FOBT or FSIG or BE then COL for all positive results /COL/ CTC (Arm1)	Arm2 FOBT Arm3 FSIG Arm4 BE Arm5 COL Arm6 CTC	Arms 3, 4 and 6 showed strong dominance compared with Arm1, ICERs of Arm2 and Arm5 below threshold value of €35,000. Technology overlapping was not cost-effective
Sonnenberg (2002)	3 rd party payer perspective	50 yr olds hypothetical population, US	COL once at 65 years COLq10Y from 50 years of age	Not specified, possibly no screening	Compared to no screening, the ICER of a single or repeated COL amounts to \$2981 or to \$10983 per LYG, respectively. A single COL saves most life years if done at the age of 60, but becomes most CE after the age of 70. Depending on the level of compliance, repeated COL save 2-3 times more lives than a screening program based on a single COL.
Howard (2005)	Not stated, US	50 yr olds who are offered annual FOBT and follows them until death	FOBT	No screening same as Sonneberg (2000)	The way in which participation rate is modelled, particularly assumptions made about the subsequent screening behaviour of non-participants ('if' and 'when' a non-participant attends for subsequent screening), affects the cost-effectiveness estimates for FOBT screening programmes. 100% participation in all screening gives USD per life-years saved of \$9705.

Table A3.4 Summary of included studies

Author	Perspective	Population	Intervention(s)	Comparators	Reported results
Pickhardt (2007)	Not stated	People 50yrs with small (6-9 mm) polyps detected at CTC screening, US	CTC with no polyp size reporting threshold CTC with a 6-mm polyp size reporting threshold	COL plus polypectomy FSIG No screening	Compared with No screening; \$4361(CTC with a 6-mm threshold), \$7138 (CTC with no threshold), \$7407(FSIG), \$9180 (COL). Compared with COL, CTC with a 6-mm threshold resulted in a 77.6% reduction in invasive endoscopic procedures and 1112 fewer reported COL-related complications from perforation or bleeding.
Hassan (2007)	National level in Italy	50yrs for 30 yrs, US	All q10Y; CTC screening COL FS	No screening	65% initial adherence and a compliance with repeat examinations of 80%, COLq10Y appeared to be the most effective technique preventing 40.9% of CRC, whilst CTC resulted to be less effective than COL (38.2%), but more effective than FSIG (31.8%), corresponding to 3821, 3589, and 2945 LYS, respectively.
Hassan (2008)	Societal	50yrs and over, US	CapEndo q10Y (capsule endocsopy; Pillcam Colon)	COL q10Y no screening	At baseline, the incremental cost-effectiveness (compared to no screening) of COL and CapEndo was \$16,165 and \$29,244 per life-years saved (LYS), respectively. When equal compliance was simulated, the COL program was more effective and less costly than a strategy based on CapEndo. When simulating an initial compliance to CapEndo 30% better than COL, CapEndo became more effective and more cost-effective option. A 20% better compliance was sufficient when a higher accuracy of CapEndo for polyps was assumed. A 6 mm threshold for polypectomy referral was associated with a substantial cost reduction in the CapEndo program with only a small loss of efficacy.
Hassan (2009b)	Societal perspective	Hypothetical cohort aged 50-100 yrs, US	COLq10Y CTC q5Y FSIG q5Y BE q5Y	Not stated	In the reference-case analysis, COL was optimal test with the highest net benefit (\$1945 per subject invited for screening compared with \$1862, \$1717, and \$1653 for CTC, FISG, and BE, respectively). Results of PSA indicated that COL was the optimal choice in only 45% of the simulated scenarios, whereas CTC, FSIG, and BE were the optimal strategies in 23%, 16%, and 15% of the scenarios, respectively. Only two parameters were responsible for most of this uncertainty about the optimal test for CRC screening: the increase in adherence with less invasive tests

Table A3.4 Summary of included studies

Author	Perspective	Population	Intervention(s)	Comparators	Reported results
					and CRC natural history. The expected societal monetary benefit of further research in these areas was estimated to be more than \$15 billion.
Flanagan(2003)	5%	Hypothetical sample of 7,001,322 people 50-74yrs with no history of CRC, Canada	FOBTq2Y (Hemoccult II nonrehydrated)	No screening	Compared with no screening, the discounted ICER of biennial screening was \$11,907. The ICNER of annual screening was \$13,497. When the costs were increased, the ICER was \$18,445 with biennial screening and \$19,893 with annual screening. Participation rate was an important determinant of the CE of the screening programme. When the participation rate was reduced from 67% to 50%, the biennial screening became less cost effective (\$15,688).
Frazier (2000)	Not clearly stated	50yrs average risk (screening surveillance till 85yrs), US	rFOBT(rehydrated) uFOBT(unrehydrated) FSIG DCBE COL	No screening	FOBT rehydrated (annual) + FSIG plus COL (if polyp found) ICER USD92900/LYG compared with no screening among white men
Hassan (2009a)	Societal	60yrs postpolypectomy surveillance, US	at 1Y COL surveillance postpolypectomy	No referral for COL after polypectomy	"COL at1Y as compared with a no COL at 1Y postpolypectomy, was a relatively CE with an ICER of \$66,136, which is well below the arbitrary threshold of \$150,000"
Helm (2000)	Not stated, possibly societal perspective	45-74 yrs general population in the US	FOBT	No screening	More than 1 million CRC could be expected to arise over 10 yr in the cohort of US residents eligible to enter a screening program in 1997, and trial outcomes indicate that ≥60% of these cancers would be fatal. If the 60-67% compliance rate of the population-based RCTs were achieved, a FOBT program would detect 30% of known CRCs and save 100,000 lives over 10 yr. Screening

Table A3.4 Summary of included studies

Author	Perspective	Population	Intervention(s)	Comparators	Reported results
					would incur total costs of \$3-4 billion over 10 yr, or \$2,500 per life-year saved.
Heresbach (2010a)	3 rd party payer	CTC offered at 50yrs, 60yrs, 70yrs, US	CTC without polyp size reporting threshold (PL strategy) CTC with polyp size reporting threshold (TS)	No screening	ICER of PL and TS strategies were 12042 and 2765/life-years gained (LYG) associated to CRC prevention rates of 37.9 and 36.5%. ICER of PL and TS strategies dropped to 9687 and 1857/LYG when AA prevalence increased from 6.9 to 8.6% for male participants and 3.804.9% for female participants or to 9482 and 2067/LYG when adenoma and AA annual recurrence rates dropped to 3.2 and 0.25%. ICER for PL and TS strategies decreased to 7947 and 954/LYG or when only two CTC performed at 50 and 60yrs. conversely ICER did not significantly change when varying population rate or accuracy of CTC.
Sonnenberg (1999)	3 rd party payer	50yrs average risk, US	CTC q10Y MRC (magnetic resonance colonography)	Polypectomy then; COL q10Y COL q3Y	Under baseline conditions, screening by COL \$20,930 per LYS, CTC \$24,586 per life-years saved (LYS). ICER comparing CTC to no screening and COL to CTC were \$11,484 and \$10,408, respectively. Col screening remains more CE even if the sensitivity (Se) and specificity (Sp) of CTC both rise to 100%. For the two screening procedures to become similarly CE, CTC needs to be associated with an initial compliance rate 15-20% better or procedural costs 54% less than COL.
Stone (2004)	3 rd party payer	Australian population at average risk, Australia	CRC FOBTq2Y 55-69yrs olds	Current practice (opportunistic screening) Base program extension to include; 45-49, 50-54, 70-74, 75+	We estimate a minimum of 'base program of screening those aged 56 to 69 years could avert 250 deaths per annum (95% uncertainty interval 99-440), at a gross cost of \$A55 million (95% UI \$A46 million to \$A 96 million) and a gross incremental cost effectiveness ratio of \$A 17,000/disability-adjusted life years (DALY; 95% UI \$A 13,000/DALY to \$A 52,000/DALY). Extending the program to include 70 to 74 years olds is a more effective option (cheaper and higher health gain) than including the 50 to 54yr olds.

Table A3.4 Summary of included studies

Author	Perspective	Population	Intervention(s)	Comparators	Reported results
Regge (2009)	Societal perspective	Average risk 50yrs, US	CTC with CAD (software, computer aided detection) CTC without CAD as a 2nd reader performed by radiologists with different level of experience.	CTC FSIG COL No screening	CAD CTC vs CTC, \$8661/LYG (inexperience readers), \$61354/LYG (experienced readers); COL vs CAD CTC \$498 668/LYG (experienced). For inexperienced readers CAD CTC was more clinically effective and CE than FSIG
Wong (2004)	Not stated	50-70 yrs of age, time horizons of 50Y, Singapore	gFOBT q1Y iFOBT q1Y DCBE q3Y FSIG q5Y COL q10Y	No screening	"Results are reported by giving the average cost and life expectancy for the subgroup within the population from the age of 50-69 through to 70." FOBT is superior in terms of cost for LIS, SGD 162.11/LYS at 100% compliance. COL was most expensive strategy.
Tsoi (2008)	Possibly payer perspective	50yrs average risk, China	FOBT FOBT then COL FSIG q5Y COL then CS q3Y for polyps COL then FOBT q10Y for no-polyps	No screening	Assume comp rate 90%, ICER for FOBT USD 6222/LYS and COL USD 7211/LYS. Even comp rate of FOBT were 50% and 30%, FOBT has the lowest ICER.
Lansdorp-Vogelaar (2009b)	Not stated	40yrs old black and white men and women in the US	COLq10Y COLq8Y individualized COL according to gender and race (white men 53-74yrs COLq7Y, black men 47-75yrs COLq7yrs, white women 53-77yrs COLq8Y, black women 47-75yrs COLq7Y)	No screening	The base-case strategy of no screening was the least expensive, yet least effective. The uniform 10Y COL strategy was dominated. The uniform 8Y COL and individualized strategies both increased life-expectancy by 0.0433-0.0435 years per individual at a cost of \$15,565 per LYG. In the individualized strategy, African Americans began screening 6years earlier with a 1-year shorter interval compared with whites. The individualized policies were essentially the same for men and women, because the higher CRC risk in men is offset by their shorter life-expectancy. The results were robust for changes in model assumptions.

Table A3.4 Summary of included studies

Author	Perspective	Population	Intervention(s)	Comparators	Reported results
O'Leary (2004)	Government-funded health system	50-64yrs, analysis over a 10-year time frame, Australia	FSIG q10Y COL q10Y FOBT q1Y FOBT q2Y	No screening	COL averted the greatest No of cases of CRC (35%), followed by FSIG *25%), and annual (25%) and biennial (14%) FOBT. COL averted the greatest number of deaths from CRC (31%), followed by annual FOBT (28%), FSIG (21%) and biennial FOBT (19%). FSIG was the most efficient in terms of cost per LYS (A\$ 16,801), followed by COL (A\$ 19,285), biennial (A\$ 41,183), and annual (A\$ 46,900) FOBT.
Park (2005)	Korean NHI	50yrs average risk in NHI, Korea	COLq5Y; COLq3Y COLq10Y; COLat50 SIGq3Y; SIGq5Y SIGq10Y; SIGat55 SIGq5Y+DCBEq5Y FOBTq2Y; FOBTq1Y DCBEq10Y; DCBEq5Y DCBEq3Y	No screening	With the NHI did not cover the screening and compliance was 30%, non-dominated strategies were COLq5Y and COLq3Y. In all scenarios of various compliance rates with raised coverage of the NHI and increased reimbursement of OCL, COLq10Y, COLq5Y and COLq3Y were non-dominated strategies, and COLq10Y had lower or minimal incremental medical cost and financial burden on the NHI than the strategy of no screening. These results were stable with sensitivity analyses.
Sobhani (2011)	Payer - health care system	people without symptoms, France	iFOBTq2Y MagStream 1xsample gFOBTq2Y OC-SENSOR 1x sample OC-SEONSOR 2x samples OC-SENSOR 3xsamples		The results suggest that a 3-sample iFOBT with 50 ng/mL as a positive cutoff is cost-effective. It provides more asymptomatic cancer detection without significantly increasing normal COL
van Rossum (2011)	3rd party payer	50-75yrs Dutch population time horizon 10 years, The Netherlands	iFOBT once gFOBT once	No screening	iFOBT dominated the alternatives: after one round of iFOBT screening, a hypothetical persone would on average gain 0.003 life-years and save the health care system 27 Euro compared with gFOBT and 0.003 LY and 72 Euro compared with no screening. Overall, in 4,460,265 Dutch aged 50-75yrs, after one round iFOBT screening, 13,400 LY and 320 million Euro would have been saved compared with no screening. iFOBT also dominated in sensitivity analyses, varying uncertainty surrounding important effect and cost parameters.

Table A3.4 Summary of included studies

Author	Perspective	Population	Intervention(s)	Comparators	Reported results
Wang (2012)	Not stated	50-80yrs Chinese individuals, China	Repeat COL	Single COL No screening	Assuming a first-time compliance rate of 90%, repeat screening COL and single COL can reduce the incidence of CRC by 65.8% and 67.2% respectively. The incremental cost-effectiveness ratio for single COL (49 Renminbi Yuan [RMB]) was much lower than that for repeat screening COL (474 RMB). Single COL was a more cost-effective strategy, which was not sensitivity to the compliance rate of COL and the cost of advanced CRC.
Whyte (2012)	NHS	50-100yrs, UK	gFOBT at 60-69 q2Y gFOBT at 60-74 q2Y iFOBT at 60, 65, 70yrs iFOBT at 60-69yrs iFOBT at 60-74yrs q2Y FSIG age 55yrs; FSIG 55, 65yrs; FSIG 55yrs and gFOBT q2Y 66-74yrs; FSIG 55yrs and iFOBT 60,65,70; FISG 55yrs, and iFOBT 60-74 q2Y; FSIG 55yrs, and iFOBT 56-74 q2Y	No screening	The model suggests that screening strategies involving FSIG or iFOBT (immunochemical FOBT) may produce additional benefits compared with the current policy of FOBTq2Y for 60-74yrs. The age at which a single FSIG screen results in the greatest QALY gain was 55, with similar gains for ages between 52 and 58. Strategies which combined FSIG and iFOBT showed further benefits and improved economic outcomes.
Wilschut (2011a)	Not stated	Age to start screening (45,50,55,60), stop screening age (70,75,80) in Netherlands (N=30000)	Different FIT cut off level of 50, 75, 100, 150, 200 ng/mL Hb. For each cutoff level, screening strategies were assessed with various age ranges and screen intervals	See intervention(s)	At all cost levels, FIT screening between age 55 and 75 yrs using FIT at 50 ng/mL, for example, was €3900/LYG. FIT screening is more cost-effective at a cutoff level of 50 ng/mL than at higher cutoff levels - which is considerably lower than the values used in current practice.

Table A3.4 Summary of included studies					
Author	Perspective	Population	Intervention(s)	Comparators	Reported results
Wilschut (2012b)	Not stated	45-80yrs Dutch population - attendance rate, costs, positivity, and detection rates from two Dutch implementation trials were analysed, the Netherlands	FIT at varying Hb cutoff levels under different capacities	gFOBT	When COL capacity was unlimited, the optimal screening strategy was to administer an annual FIT with a 50 ng/mL Hb cutoff level in individuals aged 45-80yrs and to offer COL surveillance to all individuals with adenomas. When Col capacity was decreasing, the optimal screening adaptation was to first increase the FIT Hb cutoff value to 200 ng Hb per mL and narrow the age range of 50-75yrs, to restrict COL surveillance, and finally to further decrease the number of screening rounds. FIT screening was always more cost-effective compared with gFIBT. Doubling COL capacity increased the benefits of FIT screening up to 100%.

Table A3.5 Search update - Included studies

1	Barouni, M., et al., <i>Markov's modeling for screening strategies for colorectal cancer</i> . Asian Pacific Journal of Cancer Prevention, 2012. 13 (10): p. 5125-5129.
2	Dinh, T., et al., <i>Health Benefits and Cost-effectiveness of a Hybrid Screening Strategy for Colorectal Cancer</i> . Clinical Gastroenterology and Hepatology, 2013. 11 (9): p. 1158-1166.
3	Goede, S.L., et al., <i>Cost-effectiveness of one versus two sample faecal immunochemical testing for colorectal cancer screening</i> . Gut. 62 (5): p. 727-34.
4	Hashimoto, Y., et al., <i>Cost-effectiveness analysis of CT colonography for colorectal cancer screening program to working age in Japan</i> . Value in Health Regional Issues, 2014. 3 (1): p. 182-189.
5	Huang, W., et al., <i>Cost-effectiveness of colorectal cancer screening protocols in urban Chinese populations</i> . PloS one, 2014. 9 (10): p. e109150.
6	Knudsen, A.B., et al., <i>Rescreening of persons with a negative colonoscopy result: Results from a microsimulation model</i> . Annals of Internal Medicine, 2012. 157 (9): p. 611-620. Meenan, R.T., et al., <i>An economic evaluation of colorectal cancer screening in primary care practice</i> . American Journal of Preventive Medicine, 2015. 48 (6): p. 714-721.
7	Sekiguchi, M., et al., <i>Cost-effectiveness of total colonoscopy in screening of colorectal cancer in Japan</i> . Gastroenterology Research and Practice, 2012(728454).
8	Sharaf, R.N. and U. Ladabaum, <i>Comparative effectiveness and cost-effectiveness of screening colonoscopy vs. Sigmoidoscopy and alternative strategies</i> . American Journal of Gastroenterology, 2013. 108 (1): p. 120-132.
9	Van Hees, F., et al., <i>The appropriateness of more intensive colonoscopy screening than recommended in medicare beneficiaries: A modeling study</i> . JAMA Internal Medicine, 2014. 174 (10): p. 1568-1576.
10	Wong, C.K.H., et al., <i>Cost-effectiveness simulation and analysis of colorectal cancer screening in Hong Kong Chinese population: Comparison amongst colonoscopy, guaiac and immunologic fecal occult blood testing</i> . BMC Cancer, 2015. 15 (1).

APPENDICES TO CHAPTER 4

Table A4.1 Search strategy for MEDLINE

Database: Ovid MEDLINE(R), Ovid MEDLINE(R) In-Process & Other Non-Indexed Citations, Ovid MEDLINE(R) Daily and Ovid OLDMEDLINE(R) <1946 to Present>	
Platform used: OvidSP	
Date run: 30 October 2015	
Search Strategy:	
1	Economics/ or exp "Costs and Cost Analysis"/ or exp Economics, Hospital/ or exp Economics, Medical/ or Economics, Nursing/ or Economics, Pharmaceutical/ or Budgets/ or exp Models, Economic/ or Markov Chains/ or Monte Carlo Method/ or Decision Trees/
2	(econom\$ or cba or cea or cua or markov\$ or (monte adj carlo) or (decision adj2 (tree\$ or analys\$)) or (cost or costs or costing\$ or costly or costed) or (price\$ or pricing\$) or budget\$ or expenditure\$ or (value adj2 (money or monetary)) or (pharmacoeconomic\$ or (pharmaco adj economic\$))).ti,ab.
3	1 or 2
4	"Value of Life"/
5	Quality-Adjusted Life Years/
6	quality adjusted life year.tw.
7	(qaly\$ or qald\$ or qale\$ or qtime\$).tw.
8	disability adjusted life.tw.
9	daly\$.tw.
10	Health Status Indicators/
11	(sf36 or sf 36 or short form 36 or shortform 36 or sf thirtysix or sf thirty six or shortform thirtysix or shortform thirty six or short form thirtysix or short form thirty six).tw.
12	(sf6 or sf 6 or short form 6 or shortform 6 or sf six or sfsix or shortform six or short form six).tw.
13	(sf12 or sf 12 or short form 12 or shortform 12 or sf twelve or sftwelve or shortform twelve or short form twelve).tw.
14	(sf16 or sf 16 or short form 16 or shortform 16 or sf sixteen or sfsixteen or shortform sixteen or short form sixteen).tw.
15	(sf20 or sf 20 or short form 20 or shortform 20 or sf twenty or sftwenty or shortform twenty or short form twenty).tw.
16	(euroqol or euro qol or eq5d or eq 5d).tw.
17	(qol or hql or hqol or hrqol).tw.
18	(hye or hyes).tw.
19	health\$ year\$ equivalent\$.tw.
20	utilit\$.tw.
21	(hui or hui\$1 or hui\$2 or hui\$3).tw.
22	disutili\$.tw.
23	rosser.tw.
24	quality of wellbeing.tw.
25	quality of well-being.tw.
26	qwb.tw.
27	willingness to pay.tw.
28	standard gamble\$.tw.

29	time trade off.tw.
30	time tradeoff.tw.
31	tto.tw.
32	mapping.tw.
33	mapped.tw.
34	crosswalk.tw.
35	transfer\$ to utilit\$.tw.
36	or/4-35
37	((colorectal or colon\$ or rectal or rectum\$) and (cancer\$ or tumor\$ or tumor\$ or neoplasm\$ or carcinoma\$ or adenoma\$)).tw.
38	Colorectal Neoplasms/ or Colonic Neoplasms/ or rectal neoplasms/
39	crc.tw.
40	37 or 38 or 39
41	36 and 40
42	3 and 41
43	limit 42 to humans

Table A4.2 Search strategy for mapping studies - MEDLINE

Database: Ovid MEDLINE(R) In-Process & Other Non-Indexed Citations, Ovid MEDLINE(R) Daily, Ovid MEDLINE(R) and Ovid OLDMEDLINE(R) <1946 to Present>	
Platform used: OvidSP. Date run: 30 October 2015	
Search strategy	
1	((colorectal or colon\$ or rectal or rectum\$) and (cancer\$ or tumor\$ or tumor\$ or neoplasm\$ or carcinoma\$ or adenoma\$)).tw.
2	Colorectal Neoplasms/ or Colonic Neoplasms/ or rectal neoplasms/
3	crc.tw.
4	or/1-3
5	mapping\$.tw.
6	mapped\$.tw.
7	(crosswalk\$ or cross walk\$).tw.
8	transfer\$ to utilit\$.tw.
9	(euroqol or euro qol or eq5d or eq 5d).tw.
10	(sf36 or sf 36 or short form 36 or shortform 36 or sf thirtysix or sf thirty six or shortform thirtysix or shortform thirty six or short form thirtysix or short form thirty six).tw.
11	(sf6 or sf 6 or short form 6 or shortform 6 or sf six or sfsix or shortform six or short form six).tw.
12	(sf12 or sf 12 or short form 12 or shortform 12 or sf twelve or sftwelve or shortform twelve or short form twelve).tw.
13	(sf16 or sf 16 or short form 16 or shortform 16 or sf sixteen or sfsixteen or shortform sixteen or short form sixteen).tw.
14	(sf20 or sf 20 or short form 20 or shortform 20 or sf twenty or sftwenty or shortform twenty or short form twenty).tw.
15	or/5-14
16	4 and 15
17	limit 16 to humans
18	remove duplicates from 17

Table A4.3 Study selection criteria

Studies were excluded if	<ul style="list-style-type: none">• the title/abstract were irrelevant to HRQoL or CRC-related HSUVs• conference abstracts with no full publication• Psychometric validation studies or description of health states without interval properties rather than valuation of health states• values were previously reported in other included studies• unspecified/ not clearly specified health states relating to CRC• primary mapping function is not reported in studies
Studies were included if	CRC-related HSUVs which were had not been reported previously which were <ul style="list-style-type: none">• preference-based generic measure such as EQ-5D, HUI3, and SF-6D• or directly valued health state descriptions• or mapping to generic preference-based measures based on direct statistical association mapping

Table A4.4 Included studies

1	Boyd, N.F., et al., <i>Whose utilities for decision analysis?</i> Medical Decision Making, 1990. 10 (1): p. 58-67.
2	Smith, R., et al., <i>A cost-utility approach to the use of 5-fluorouracil and levamisole as adjuvant chemotherapy for Dukes' C colonic carcinoma.</i> Medical Journal of Australia, 1993. 158 :319-322.
3	Dominitz, J.A. and D. Provenzale, <i>Patient preferences and quality of life associated with colorectal cancer screening.</i> Am J Gastroenterol, 1997. 92 (12): p. 2171-8.
4	Norum, J., et al., <i>Adjuvant chemotherapy (5-fluorouracil and levamisole) in Dukes' B and C colorectal carcinoma. A cost-effectiveness analysis.</i> Annals of Oncology, 1997. 8 (1): p. 65-70.
5	Petrou, S. and N. Campbell, <i>Stabilisation in colorectal cancer.</i> International Journal of Palliative Nursing, 1997. 3 (5): p. 275.
6	Syngal, S., et al., <i>Benefits of colonoscopic surveillance and prophylactic colectomy in patients with hereditary nonpolyposis colorectal cancer mutations.</i> Annals of Internal Medicine, 1998. 129 (10): p. 787-96.
7	Ness, R.M., et al., <i>Utility valuations for outcome states of colorectal cancer.</i> American Journal of Gastroenterology, 1999. 94 (6): p. 1650-7.
8	Miller, A., et al., <i>Quality of life and cost effectiveness analysis of therapy for locally recurrent rectal cancer.</i> Diseases of the Colon and Rectum, 2000. 1695-1703 .
9	Ramsey, S.D., et al., <i>Quality of life in survivors of colorectal carcinoma.</i> Cancer, 2000. 88 (6): p. 1294-1303.
10	Hamashima, C., <i>Long-term quality of life of postoperative rectal cancer patients.</i> Journal of Gastroenterology & Hepatology, 2002. 17 (5): p. 571-6.
11	Ramsey, S.D., et al., <i>Quality of life in long term survivors of colorectal cancer.</i> Am J Gastroenterol, 2002. 97 (5): p. 1228-34.
12	van den Brink, M., et al., <i>Cost-utility analysis of preoperative radiotherapy in patients with rectal cancer undergoing total mesorectal excision: a study of the Dutch Colorectal Cancer Group.</i> Journal of clinical oncology : official journal of the American Society of Clinical Oncology, 2004. 22 (2): p. 244-253.
13	Gosselink, M.P., et al., <i>Quality of life after total mesorectal excision for rectal cancer.</i> Colorectal Disease, 2006. 8 (1): p. 15-22.
14	Smith, D.M., et al., <i>Misremembering colostomies? Former patients give lower utility ratings than do current patients.</i> Health Psychol, 2006. 25 (6): p. 688-95.
15	Wilson, T.R., D.J. Alexander, and P. Kind, <i>Measurement of health-related quality of life in the early follow-up of colon and rectal cancer.</i> Diseases of the Colon & Rectum, 2006. 49 (11): p. 1692-702.
16	Doornebosch, P.G., et al., <i>Quality of life after transanal endoscopic microsurgery and total mesorectal excision in early rectal cancer.</i> Colorectal Disease, 2007. 9 (6): p. 553-558.
17	Sharma, A., et al., <i>Predictors of early postoperative quality of life after elective resection for colorectal cancer.</i> Annals of Surgical Oncology, 2007. 14 (12): p. 3435-3442.
18	Doornebosch, P.G., et al., <i>Impact of transanal endoscopic microsurgery on functional outcome and quality of life.</i> International Journal of Colorectal Disease, 2008. 23 (7): p. 709-713.
19	Cheung, Y.B., et al., <i>Mapping the English and Chinese versions of the Functional Assessment of Cancer Therapy-General to the EQ-5D utility index.</i> Value Health, 2009. 12 (2): p. 371-6.

20	Mittmann, N., et al., <i>Prospective cost-effectiveness analysis of cetuximab in metastatic colorectal cancer: Evaluation of national cancer institute of canada clinical trials group CO.17 Trial</i> . Journal of the National Cancer Institute, 2009. 101 (17): p. 1182-1192.
21	Shiroiwa, T., T. Fukuda, and K. Tsutani, <i>Cost-effectiveness analysis of XELOX for metastatic colorectal cancer based on the NO16966 and NO16967 trials</i> . British Journal of Cancer, 2009. 101 (1): p. 12-8.
22	Best, J.H., et al., <i>Preference values associated with stage III colon cancer and adjuvant chemotherapy</i> . Quality of Life Research, 2010. 19 (3): p. 391-400.
23	Wiering, B., et al., <i>Added value of positron emission tomography imaging in the surgical treatment of colorectal liver metastases</i> . Nuclear Medicine Communications, 2010. 31 (11): p. 938-44.
24	Bennett, L., et al., <i>Health-related quality of life in patients with metastatic colorectal cancer treated with panitumumab in first- or second-line treatment</i> . Br J Cancer, 2011. 105 (10): p. 1495-502.
25	Haapamaki, M.M., et al., <i>Physical performance and quality of life after extended abdominoperineal excision of rectum and reconstruction of the pelvic floor with gluteus maximus flap</i> . Diseases of the Colon & Rectum, 2011. 54 (1): p. 101-6.
26	Hornbrook, M.C., et al., <i>Complications among colorectal cancer survivors: SF-6D preference-weighted quality of life scores</i> . Medical Care, 2011. 49 (3): p. 321-326.
27	Odom, D., et al., <i>Health-related quality of life and colorectal cancer-specific symptoms in patients with chemotherapy-refractory metastatic disease treated with panitumumab</i> . Int J Colorectal Dis, 2011. 26 (2): p. 173-81.
28	Wang, J., et al., <i>A Q-TWiST analysis comparing panitumumab plus best supportive care (BSC) with BSC alone in patients with wild-type KRAS metastatic colorectal cancer</i> . Br J Cancer, 2011. 104 (12): p. 1848-53.
29	Wiering, B., et al., <i>Long-term global quality of life in patients treated for colorectal liver metastases</i> . British Journal of Surgery, 2011. 98 (4): p. 565-71; discussion 571-2.
30	Dranitsaris, G., et al., <i>Improving patient access to cancer drugs in India: Using economic modeling to estimate a more affordable drug cost based on measures of societal value</i> . International Journal of Technology Assessment in Health Care, 2011a. 27 (1): p. 23-30.
31	Dranitsaris, G., et al., <i>Using pharmacoeconomic modelling to determine value-based pricing for new pharmaceuticals in Malaysia</i> . Malaysian Journal of Medical Sciences, 2011b. 18 (4):31-42.
32	Kapidzic, A., et al., <i>Quality of life in participants of a CRC screening program</i> . Br J Cancer, 2012. 107 (8): p. 1295-301.
33	Kim, S.H., et al., <i>Mapping EORTC QLQ-C30 onto EQ-5D for the assessment of cancer patients</i> . Health Qual Life Outcomes, 2012. 10 : p. 151.
34	Pickard, A.S., et al., <i>Comparison of FACT- and EQ-5D-based utility scores in cancer</i> . Value Health, 2012. 15 (2): p. 305-11.
35	Wong, C.K., et al., <i>Mapping the Functional Assessment of Cancer Therapy-general or -Colorectal to SF-6D in Chinese patients with colorectal neoplasm</i> . Value in Health, 2012. 15 (3): p. 495-503.
36	Dranitsaris, G., et al., <i>A pharmacoeconomic modeling approach to estimate a value-based price for new oncology drugs in Europe</i> . Journal of Oncology Pharmacy Practice, 2012a. 18 (1): p. 57-67.
37	Dranitsaris, G., et al., <i>The application of pharmacoeconomic modelling to estimate a value-based price for new cancer drugs</i> . Journal of Evaluation in Clinical Practice, 2012b. 18 (2): p. 343-51.

38	Andersson, J., et al., <i>Health-related quality of life after laparoscopic and open surgery for rectal cancer in a randomized trial</i> . British Journal of Surgery, 2013. 100 (7): p. 941-9.
39	Augustad, K., et al., <i>Cost-effectiveness and quality of life in surgeon versus general practitioner-organised colon cancer surveillance: a randomised controlled trial</i> . BMJ Open, 2013. 3 (4):e002391.
40	Farkkila, N., et al., <i>Health-related quality of life in colorectal cancer</i> . Colorectal Disease, 2013. 15 (5): p. e215-e222.
41	Lee, L., et al., <i>Valuing postoperative recovery: validation of the SF-6D health-state utility</i> . Journal of Surgical Research, 2013. 184 (1): p. 108-114.
42	Schwandner, O., <i>Sacral neuromodulation for fecal incontinence and "low anterior resection syndrome" following neoadjuvant therapy for rectal cancer</i> . International Journal of Colorectal Disease, 2013. 28 (5): p. 665-9.
43	Wong, C.K., et al., <i>Predicting SF-6D from the European Organization for Treatment and Research of Cancer Quality of Life Questionnaire scores in patients with colorectal cancer</i> . Value in Health, 2013a. 16 (2): p. 373-84.
44	Wong, C.K., et al., <i>Clinical correlates of health preference and generic health-related quality of life in patients with colorectal neoplasms</i> . PLoS ONE [Electronic Resource], 2013b. 8 (3): p. e58341.
45	Brown, S.R., et al., <i>The impact of postoperative complications on long-term quality of life after curative colorectal cancer surgery</i> . Annals of Surgery, 2014. 259 (5): p. 916-23.
46	Carter, H.E., et al., <i>The cost effectiveness of bevacizumab when added to capecitabine, with or without mitomycin-C, in first line treatment of metastatic colorectal cancer: Results from the Australasian phase III MAX study</i> . European journal of cancer (Oxford, England: 1990), 2014. 50 (3): p. 535-543.
47	Jordan, J., et al., <i>Laparoscopic versus open colorectal resection for cancer and polyps: A cost-effectiveness study</i> . ClinicoEconomics and Outcomes Research, 2014. 6 : p. 415-422.
48	Kim, S.H., et al., <i>Deriving a mapping algorithm for converting SF-36 scores to EQ-5D utility score in a Korean population</i> . Health and quality of life outcomes, 2014. 12 : p. 145.
49	Polat, U., et al., <i>Evaluation of quality of life and anxiety and depression levels in patients receiving chemotherapy for colorectal cancer: Impact of patient education before treatment initiation</i> . Journal of Gastrointestinal Oncology, 2014. 5 (4): p. 270-275.
50	Stein, D., et al., <i>Assessing health-state utility values in patients with metastatic colorectal cancer: a utility study in the United Kingdom and the Netherlands</i> . International Journal of Colorectal Disease, 2014. 29 (10): p. 1203-10.
51	Ward, P., et al., <i>Physical function and quality of life in frail and/or elderly patients with metastatic colorectal cancer treated with capecitabine and bevacizumab: an exploratory analysis</i> . Journal of Geriatric Oncology, 2014. 5 (4): p. 368-75.
52	Wong, C.K., et al., <i>Responsiveness was similar between direct and mapped SF-6D in colorectal cancer patients who declined</i> . Journal of Clinical Epidemiology, 2014. 67 (2): p. 219-27.
53	Yang, Y., et al., <i>Improving the mapping of condition-specific health-related quality of life onto SF-6D score</i> . Quality of life research: an international journal of quality of life aspects of treatment, care and rehabilitation, 2014. 23 (8): p. 2343-2353.
54	Downing, A., et al., <i>Health-related quality of life after colorectal cancer in England: a patient-reported outcomes study of individuals 12 to 36 months after diagnosis</i> . Journal of Clinical Oncology, 2015. 33 (6): p. 616-24.

55	Hall, P.S., et al., <i>Costs of cancer care for use in economic evaluation: a UK analysis of patient-level routine health system data</i> . British Journal of Cancer, 2015. 112 (5): p. 948-56.
56	Hompes, R., et al., <i>Evaluation of quality of life and function at 1 year after transanal endoscopic microsurgery</i> . Colorectal Disease, 2015. 17 (2): p. O54-O61.
57	Young, C.J., et al., <i>Improving Quality of Life for People with Incurable Large-Bowel Obstruction: Randomized Control Trial of Colonic Stent Insertion</i> . Diseases of the Colon & Rectum, 2015. 58 (9): p. 838-49.

Table A4.5 Summary of studies reporting HSUVs in CRC

Table A4.5 Summary of studies reporting HSUVs in CRC			
Author (year)	Measured by	Reported CRC-related utility values	Abbreviations/Keys
Andersson (2013)	EQ-5D	Pre-4 weeks-6 months(m)-12m Lap 0.77-0.642-0.775-0.794 Open 0.749-0.626-0.757-0.787	Pre: preoperative; Lap: laparoscopic surgery; Open: open surgery Re-expressed on a 0-1 scale
Augestad (2013)	EQ-5D	mean EQ-5D (SD); baseline-12m-24m Surgeon-led 0.83(0.16) - 0.85(0.20) - 0.90(0.14) GP-led 0.79(0.22) - 0.87(0.18) - 0.89(0.13)	SD standard deviation m months
Bennett (2011)	EQ-5D	1 st line EQ-5D baseline mean (SD) P+FOLFOX4 0.778 (0.247); FOLFOX4 0.756 (0.244) 2 nd line EQ-5D baseline mean (SD) P+FOLFIRI 0.769 (0.230); FOLFIRI 0.762 (0.252)	P panitumumab FOLFIRI fluorouracil, leucovorin and irinotecan FOLFOX fluorouracil, leucovorin and oxaliplatin
Best (2010)	TTO	CRC patients/community members; Remission 0.83/0.82 adjuvant, no neuropathy 0.61/0.60 adjuvant, mild neuropathy 0.61/0.51 adjuvant, moderate neuropathy 0.53/0.46 adjuvant, severe neuropathy 0.48/0.34 metastatic, stable 0.40/0.51 metastatic, progressive 0.37/0.21	
Boyd (1990)	SG	with colostomy 0.915 without colostomy 0.804	HSUVs re-expressed on a 0-1 scale
Carter (2014)	EQ-5D	Capecitabine 0.07939 Capecitabine plus Bevacizumab 0.7839	

Table A4.5 Summary of studies reporting HSUVs in CRC

Author (year)	Measured by	Reported CRC-related utility values	Abbreviations/Keys
Dornitz (1997)	TTO	20Y your current health - 20Y with CRC - 20Y with a colostomy (IQR) Unscreened 0.95(0.85-1.00) - 0.80 (0.65-0.95) - 0.80 (0.50-0.95) Screening 0.95 (0.90-1.00)-0.80 (0.73-0.95)-0.75 (0.75-0.93) VA#380 1.00 (0.90-1.00)-0.85 (0.70-0.95)-0.79 (0.50-0.95) CRC 0.90 (0.70-0.95)-0.83 (0.70-1.00)-0.90 (0.64-1.00)	Y years VA#380 patients enrolled in VA Cooperative Studies Program #380, a colonoscopic screening program IQR interquartile range (25th and 75th percentile)
Doornebosche (2007)	EQ-5D	TEM 0.81 TME 0.76 Control 0.76	control (healthy, sex- and age-matched control group) TEM transanal endoscopic microsurgery (TEM); TME total mesorectal excision (TME) Re-expressed on a 0-1 scale
Doornebosche (2008)	EQ-5D	Control 0.86 Pre-operative 0.84 Post-operative 0.89	control (healthy, sex- and age-matched control group) Re-expressed on a 0-1 scale
Smith (2006)	TTO	Current patients 0.84 (SD 0.24) Former patients 0.64 (0.35) Community member 0.63 (0.36)	SD standard deviation

Dranitsaris (2011a)	TTO	<p>mean (95% CI); [m] time in health state in months</p> <p>#1 [10m] 0.73 (0.67-0.80) #2 [28m] 0.83 (0.78-0.89) #3 [8m] 0.72 (0.65-0.78) #4 [4m] 0.68 (0.58-0.78) #5 [6m] 0.80 (0.74-0.86) #6 [33m] 0.89 (0.86-0.92) #7 [11m] 0.78 (0.73-0.83) #8 [2m] 0.74 (0.63-0.85) #9 [10m] 0.85 (0.80-0.91) #10 [28m] 0.87 (0.81-0.92) #11 [8m] 0.60 (0.73-0.86) #12 [4m] 0.70 (0.62-0.78) #13 [6m] 0.89 (0.83-0.96) #14 [32m] 0.94 (0.90-0.97) #15 [11m] 0.88 (0.84-0.91) #16 [2m] 0.82 (0.72-0.93)</p>	<p>FOLFOX: Oxaliplatin + infusional 5 fluorouracil (5-FU); FOLFIRI: Irinotecan + infusional 5 fluorouracil (5-FU); BSC best supportive care; [m] time in health state in months</p> <p>#1 Stopped FOLFOX + the 'new drug' after 2 cycles due to side effects (SEs) and was then treated with FOLFIRI for 4 cycles. There was disease progression. The patient (pt) received BSC and died 6 months (m) later; #2 Stopped FOLFOX + the 'new drug' after 2 cycles due to SEs and was then treated with FOLFIRI. There was a response to FOLFIRI and the pt went on to receive 8 cycles. Upon progression, the pt received BSC and died 22m later; #3 Stopped FOLFOX + the 'new drug' after 2 cycles due to SEs and was then treated with FOLFIRI. There was a response to FOLFIRI and the pnt went on to receive 8 cycles. Upon progression, the pt received BSC and died 2m later; #4 Stopped FOLFOX + the 'new drug' after 2 cycles due to SEs and was then treated with FOLFIRI for 2 cycles. However, the pt died due to cancer progression within the first 2m; #5 Tolerated SEs but had disease progression after 4 cycles of FOLFOX + the 'new drug'. The pt was then treated with FOLFIRI for 4 cycles but the disease did not respond. The pt received BSC and died 2m later; #6 Tolerated SEs and responded FOLFOX + the 'new drug'. The pt went on to receive a total of 17 cycles of first line therapy. Upon progression, the pt went on to receive 6 cycles of FOLFIRI. Upon progression, the pt received BSC and died 21m later; #7 Tolerated SEs and responded FOLFOX + the 'new drug'. The pt went on to receive a total of 17 cycles of first line therapy. Upon progression, the pt went on to receive 2 cycles of FOLFIRI but died 2m later; #8 Tolerated SEs and but had disease progression after 2 cycles of FOLFOX + the 'new drug'. The pt died to the cancer 1m later; #9 Stopped FOLFOX after 2 cycles due to SEs and was then treated with FOLFIRI for 4 cycles. There was disease progression. The pt received BSC and died 6m later; #10 Stopped FOLFOX after 2 cycles due to SEs and was then treated with FOLFIRI for 4 cycles. There was disease progression. The pt received BSC and died 6m later; #11 Stopped FOLFOX after 2 cycles due to SEs and was then treated with FOLFIRI. There was a response to FOLFIRI and the pt went on to receive 8 cycles. Upon progression, the patient received BSC and died 2m later; #12 Stopped FOLFIRI after 2 cycles due to SEs and was then treated with FOLFIRI for 2 cycles. However, the pt died due to cancer progression within the first 2m; #13 Tolerated SEs but had diseases progression after 4 cycles of FOLFOX. The pt was then treated with FOLFIRI for 4 cycles but the disease did not respond. The pt received BSC and died 2m later; #14 Tolerated SEs and responded FOLFOX. The pt went on to receive a total of 15 cycles of first line therapy. Upon progression, the pt went on to receive 6 cycles of FOLFIRI. Upon progression, the patient was offered BSC and died 21m later; #15 Tolerated SEs and responded FOLFOX. The pt went on to receive a total of 15 cycles of first line therapy. Upon progression, the pt went on to receive 2 cycles of FOLFIRI but died 2m later; #16 Tolerated SEs and but had had disease progression after 2 cycles of FOLFOX. The pt died due to cancer progression 1m later.</p>
---------------------	-----	---	---

Table A4.5 Summary of studies reporting HSUVs in CRC			
Author (year)	Measured by	Reported CRC-related utility values	Abbreviations/Keys
Dranitsaris (2011b)	TTO	mean (95% CI); [m] time in health state in months #1 [10m] 0.74 (0.65-0.83) #2[28m] 0.80 (0.73-0.87) #3 [8m] 0.67 (0.61-0.73) #4 [4m] 0.74 (0.65-0.84) #5[6m] 0.82 (0.76-0.89) #6 [29m] 0.81 (0.77-0.86) #7[11m] 0.83 (0.79-0.87) #8 [2m] 0.75 (0.63-0.86) #9 [10m] 0.82 (0.75-0.82) #10 [28m] 0.81 (0.76-0.86) #11 [8m] 0.72 (0.66-0.79) #12 [4m] 0.75 (0.66-0.84) #13 [6m] 0.84 (0.76-0.92) #14 [32m] 0.91 (0.88-0.94) #15 [11m] 0.84 (0.79-0.90) #16 [2m] 0.75 (0.63-0.86)	FOLFOX: Oxaliplatin+infusional 5 fluorouracil (5-FU); FOLFIRI; Irinotecan+infusional 5 fluorouracil (5-FU); BSC best supportive care; [m] time in health state in months #1 Stopped FOLFOX+newTx after 2 cycles due to side effects(SE) and then treated with FOLFIRI for 4 cycles. There was disease progression, the patient (pt) received BSC and died 6 months (m) later; #2 Stopped FOLFOX+newTx after 2 cycles due to SE and was then treated with FOLFIRI. There was a response to FOLFIRI and pt went on to receive 8 cycles. Upon progression, BSC and died 22m later; #3 Stopped FOLFOX+newTx after 2 cycles due to SE and was then treated with FOLFIRI. There was a response to FOLFIRI and pt went on to receive 8 cycles. Upon progression, pt received BSC and died 2m later; #4 Stopped FOLFOX+new Tx after 2 cycles due to SE and was then treated with FOLFIRI for 2 cycles. However, pt died due to cancer progression within the first 2m; #5 Tolerated SE but had disease progression after 4 cycles of FOLFOX+newTx. Pt was then treated with FOLFIRI for 4 cycles but the disease did not respond. Pt received BSC and died 2m later; #6 Tolerated SE and responded FOLFOX+newTx. Pt went on to receive a total of 17 cycles of 1st line therapy. Upon progression, pt went on to receive 6 cycles of FOLFIRI but died 2m later; #7 Tolerated SE and responded FOLFOX+newTx. Pt went on to receive a total of 17 cycles of 1st line therapy. Upon progression, pt went on to receive 2 cycles of FOLFIRI but died 2m later; #8 Tolerated SE but disease progression after 2 cycles of FOLFOX+ newTx. Pt died due to the cancer 1m later; #9 Stopped FOLFOX after 2 cycles due to side effects(SE) and then treated with FOLFIRI for 4 cycles. There was disease progression, the pt received BSC and died 6 months (m) later; #10 Stopped FOLFOX after 2 cycles due to SE and was then treated with FOLFIRI. There was a response to FOLFIRI and pt went on to receive 8 cycles. Upon progression, the Pt received BSC and died 22m later; #11 Stopped FOLFOX after 2 cycles due to SE and was then treated with FOLFIRI. There was a response to FOLFIRI and pt went on to receive 8 cycles. Upon progression, pt received BSC and died 2m later; #12 Stopped FOLFOX after 2 cycles due to SE and was then treated with FOLFIRI for 2 cycles. However, pt died due to cancer progression within the first 2m; #13 Tolerated SE but had disease progression after 4 cycles of FOLFOX. Pt was then treated with FOLFIRI for 4 cycles but the disease did not respond. Pt received BSC and died 2m later; #14 Tolerated SE and responded FOLFOX. Pt went on to receive a total of 15 cycles of 1st line therapy. Upon progression, Pt went on to receive 6 cyclr of FOLFIRI. Upon progression, the pt was offered BSC and died 2m later; #15 Tolerated SE, responded FOLFOX. Pt went on to receive a total of 15 cycles of 1st line therapy. Upon progression, pt went on to receive 2 cycles of FOLFIRI but died 2m later; #16 Tolerated SE but disease progression after 2 cycles of FOLFOX. Pt died due to the cancer 1m later

Table A4.5 Summary of studies reporting HSUVs in CRC			
Author (year)	Measured by	Reported CRC-related utility values	Abbreviations/Keys
Dranitsaris (2012a)	TTO	#1 [10m] 0.53 (0.46-0.60) #2 [28m] 0.65 (0.57-0.87) #3 [8m] 0.67 (0.58-0.76) #4 [4m] 0.52 (0.42-0.62) #5 [6m] 0.61 (0.55-0.68) #6 [29m] 0.69 (0.61-0.76) #7 [11m] 0.81 (0.74-0.89) #8 [2m] 0.84 (0.75-0.94) #9 [10m] 0.54 (0.47-0.62); #10 [28m] 0.66 (0.59-0.74) #11 [8m] 0.68 (0.59-0.77) #12 [4m] 0.53 (0.43--.63) #13 [6m] 0.61 (0.55-0.68) #14 [32m] 0.65 (0.72-0.87) #15 [11m] 0.80 (0.72-0.87) #16 [2m] 0.84 (0.75-0.94)	FOLFOX: Oxaliplatin + infusional 5 fluorouracil (5-FU); FOLFIRI: Irinotecan + infusional 5 fluorouracil (5-FU); BSC best supportive care; Side effects (SEe); [m] time in health state in months #1 Stopped FOLFOX + the 'new drug' after 2 cycles due to SEs and was then treated with FOLFIRI for 4 cycles. There was disease progression. The patient (pt) received BSC and died 6 months (m) later; #2 Stopped FOLFOX + the 'new drug' after 2 cycles due to SEs and was then treated with FOLFIRI. There was a response to FOLFIRI and the pt went on to receive 8 cycles. Upon progression, the pt received BSC and died 22m later; #3 Stopped FOLFOX + the 'new drug' after two cycles due to SEs and was then treated with FOLFIRI. There was a response to FOLFIRI and the pt went on to receive 8 cycles. Upon progression, the pt received BSC and died 2m later; #4 Stopped FOLFOX + the 'new drug' after 2 cycles due to SEs and was then treated with FOLFIRI for 2 cycles. However, the pt died due to cancer progression within the first 2m; #5 Tolerated SEs but had disease progression after 4 cycles of FOLFOX + the 'new drug'. The pt was then treated with FOLFIRI for 4 cycles but the disease did not respond. The pt received BSC and died 2m later; #6 Tolerated SEs and responded FOLFOX + the 'new drug'. The pt went on to receive a total of 17 cycles of first line therapy. Upon progression, the pt went on to receive 6 cycles of FOLFIRI. Upon progression, the pt received BSC and died 21m later; #7 Tolerated SEs and responded FOLFOX + the 'new drug'. The pt went on to receive a total of 17 cycles of first line therapy. Upon progression, the pt went on to receive 2 cycles of FOLFIRI but died 2m later; #8 Tolerated SEs but had disease progression after 2 cycles of FOLFOX + the 'new drug'. The pt died due to the cancer 1m later; #9 Stopped FOLFOX after 2 cycles due to SEs and was then treated with FOLFIRI for 4 cycles. There was disease progression. The pt received BSC and died 6m later; 10 Stopped FOLFOX after 2 cycles due to SEs and was then treated with FOLFIRI. There was a response to FOLFIRI and the pt went on to receive 8 cycles. Upon progression, the pt received BSC and died 22m later; #11 Stopped FOLFOX after 2 cycles due to SEs and was then treated with FOLFIRI. There was a response to FOLFIRI and the pt went on to receive 8 cycles. Upon progression, the pt received BSC and died 2m later; #12 Stopped FOLFOX after 2 cycles due to SEs and was then treated with FOLFIRI for 2 cycles. However, the pt died due to cancer progression within the first 2m; #13 Tolerated SEs but had disease progression after 4 cycles of FOLFOX. The pt was then treated with FOLFIRI for 4 cycles but the disease did not respond. The pt received BSC and died 2m later; #14 Tolerated SEs and responded FOLFOX. The pt went onto receive a total of 15 cycles of first line therapy. Upon progression, the pt went on to receive 2 cycles of FOLFIRI. Upon progression, the pt was offered BSC and died 21m later; #15 Tolerated SEs and responded FOLFOX. The pt went on to receive a total of 15 cycles of first line therapy. Upon progression, the pt went on to receive two cycles of FOLFIRI but died 2m later; #16 Tolerated SEs but had disease progression after 2 cycles of FOLFOX. The pt died due to cancer progression 1m later.

Dranitsaris
(2012b)

TTO

#1 [10m] 0.61 (0.54-0.68)
#2 [28m] 0.63 (0.55-0.72)
#3 [8m] 0.65 (0.57-0.73)
#4 [4m] 0.47 (0.37-0.88)
#5 [6m] 0.61 (0.51-0.72)
#6 [29m] 0.72 (0.63-0.81)
#7 [11m] 0.69 (0.62-0.76)
#8 [2m] 0.44(0.32-0.56)
#9 [10m] 0.64 (0.57-0.70)
#10 [28m] 0.63 (0.55-0.72)
#11 [8m] 0.69 (0.62-0.76)
#12 [4m] 0.49 (0.38-0.60)
#13 [6m] 0.62 (0.51-0.72)
#14 [32m] 0.68 (0.56-0.80)
#15 [11m] 0.71 (0.64-0.78)
#16 [2m] 0.44 (0.32-0.56)

FOLFOX: Oxaliplatin + infusional 5 fluorouracil (5-FU); FOLFIRI: Irinotecan + infusional 5 fluorouracil (5-FU); BSC best supportive care; Side effects (SEs)

#1 Stopped FOLFOX + the 'new drug' after 2 cycles due to SEs and was then treated with FOLFIRI for 4 cycles. There was disease progression. The patient (pt) received BSC and died 6 months (m) later; #2 Stopped FOLFOX + the 'new drug' after 2 cycles due to SEs and was then treated with FOLFIRI. There was a response to FOLFIRI and the pt went on to receive 8 cycles. Upon progression, the pt received BSC and died 22m later; #3 Stopped FOLFOX + the 'new drug' after two cycles due to SEs and was then treated with FOLFIRI. There was a response to FOLFIRI and the pt went on to receive 8 cycles. Upon progression, the pt received BSC and died 2m later; #4 Stopped FOLFOX + the 'new drug' after 2 cycles. However, the pt died due to cancer progression within the first 2m; #5 Tolerated SEs but had disease progression after 4 cycles of FOLFOX + the 'new drug'. The pt was then treated with FOLFIRI for 4 cycles but the disease did not respond. The pt received BSC and died 2m later; #6 Tolerated SEs and responded FOLFOX + the 'new drug'. The pt went on to receive a total of 17 cycles of first line therapy. Upon progression, the pt went on to receive 6 cycles of FOLFIRI. Upon progression, the pt received BSC and died 21m later; #7 Tolerated SEs and responded FOLFOX + the 'new drug'. The pt went on to receive a total of 17 cycles of first line therapy. Upon progression, the pt went on to receive 2 cycles of FOLFIRI but died 2m later; #8 Tolerated SEs but had disease progression after 2 cycles of FOLFOX + the 'new drug'. The pt died due to the cancer 1m later; #9 Stopped FOLFOX after 2 cycles due to SEs and was then treated with FOLFIRI for 4 cycles. There was disease progression. The pt received BSC and died 6m later; #10 Stopped FOLFOX after 2 cycles due to SEs and was then treated with FOLFIRI. There was a response to FOLFIRI and the pt went on to receive 8 cycles. Upon progression, the pt received BSC and died 22m later; #11 Stopped FOLFOX after 2 cycles due to SEs and was then treated with FOLFIRI. There was a response to FOLFIRI and the pt went on to receive 8 cycles. Upon progression, the pt received BSC and died 2m later; #12 Stopped FOLFOX after 2 cycles due to SEs and was then treated with FOLFIRI for 2 cycles. However, the pt died due to cancer progression within the first 2m; #13 Tolerated SEs but had disease progression after 4 cycles of FOLFOX. The pt was then treated with FOLFIRI for 4 cycles but the disease did not respond. The pt received BSC and died 2m later; #14 Tolerated SEs and responded FOLFOX. The pt went onto receive a total of 15 cycles of first line therapy. Upon progression, the pt went on to receive 2 cycles of FOLFIRI. Upon progression, the pt was offered BSC and died 21m later; #15 Tolerated SEs and responded FOLFOX. The pt went on to receive a total of 15 cycles of first line therapy. Upon progression, the pt went on to receive two cycles of FOLFIRI but died 2m later; #16 Tolerated SEs but had disease progression after 2 cycles of FOLFOX. The pt died due to cancer progression 1m later.

Table A4.5 Summary of studies reporting HSUVs in CRC

Author (year)	Measured by	Reported CRC-related utility values	Abbreviations/Keys
Farkkila (2013)	EQ-5D	Primary treatment 0.760 Rehabilitation 0.835 Remission 0.850 Metastatic disease 0.820 Palliative care 0.643 All patients 0.813	
Grosslink (2006)	EQ-5D	[Note: HSUVs were estimated from Figure 1] LRA 0.77 (range 0.72-0.83) CPA 0.84 (0.80-0.89) APR 0.80(0.75-0.86)	LRA low colo-rectal anastomosis CPA colo-anal J-pouch anastomosis APR abdominoperitoneal resection
Haapamaki (2011)	EQ-5D	Mean EQ-5D 0.71 (SD 0.18)	SD standard deviation
Hamashima (2002)	EQ-5D	Without stoma 0.870 With stoma 0.836	
Hornbrook (2011)	SF-6D	With stoma 0.69 Without stoma 0.73	
Kapidzic (2012)	EQ-5D	FIT negative 0.85 FIT positive 0.82 (0.17) FS negative 0.85 (0.17) FS positive 0.80 (0.24) *Negative FIT 0.85 (0.19) *4-12 months (m) 0.85 (0.17) *13-24 m 0.85 (0.17) *25 m or more 0.89 (0.17) **FIT positive 0.82 (0.20) **4-12m 0.84 (0.20) ***13-24m 0.81 (0.23) **25m or more (0.82 (0.19) Negative FS after positive FIT 0.81 (0.21) Positive FS after positive FIT 0.82 (0.22)	FIT faecal immunochemical test FS flexible sigmoidoscopy *Mean scale scores of responders with a negative test results for the whole group and per whole group and per time period passed between participation ** Mean scale scores of responders with a positive test result for the whole group and per time period passed between participation ***Mean scale scores of responders with a positive test result (FIT) by result of the FS

Table A4.5 Summary of studies reporting HSUVs in CRC			
Author (year)	Measured by	Reported CRC-related utility values	Abbreviations/Keys
Miller (2000)	SG	Healthcare providers; patients (\pm SD) Disease recurrence 0.69 \pm 0.24; 0.72 \pm 0.22 Surgical resection 0.69 \pm 0.24; 0.83 \pm 0.18 Pain and complications 0.50 \pm 0.29; 0.78 \pm 0.27	SD standard deviation
Mittman (2009)	HUI3	Cetuximab+BSC; BSC baseline 0.72; 0.71 Week4 0.71; 0.68 Week8 0.73; 0.66 Week16 0.73; 0.63 Week24 0.77; 0.70	BSC best supportive care TOX days with \geq grade 3 adverse events TWIST time without symptoms or toxicity REL relapse period until death or end of follow-up
Ness (1999)	SG	Participant's current health 0.84 State A 0.74 State BC 0.67 State D 0.59 State E 0.50 State FG 0.25	State A: stage I rectal or stage I/II colon cancer treated with resection only; State B: Stage III colon cancer treated with resection and chemotherapy without significant side effects; State C: Stage III colon cancer treated with resection and chemotherapy (chemoTx) with significant SE; State D: stage II/III rectal cancer treated with resection/chemoTx/radiationTx; State E: stage II/III rectal cancer treated with resection/chemoTx/radiationTx/permanent ostomy; State F: stage IV metastatic/unresectable disease without ostomy; State G: stage IV metastatic/unresectable disease with ostomy
Norum (1997)	EQ-5D	EuroQoL median 0.78 (range 0.33-1.00)	
Odom (2011)	EQ-5D	Panitumumab plus BSC; BSC alone (SD) Overall 0.72 (0.24); 0.68 (0.25) Wild-type KRAS 0.73 (0.24); 0.68 (0.23) Mutant KRAS 0.71 (0.25); 0.68 (0.26)	BSC best supportive care KRAS Kirsten rat sarcoma viral oncogene homolog SD standard deviation
Petrou (1997)	SG	Partial response 1.0 Stable disease 0.95 Progressive disease 0.575 Terminal disease 0.1	HSUVs re-expressed on a 0-1 scale
Ramsey (2000)	HUI3	mean 0.85 (SD 0.15) stage I 0.84 (0.17) stage II 0.86 (0.14) stage III 0.85 (0.14) stage IV 0.84 (0.12)	SD standard deviation

Table A4.5 Summary of studies reporting HSUVs in CRC			
Author (year)	Measured by	Reported CRC-related utility values	Abbreviations/Keys
Ramsey (2002)	HUI3	Stage I 0.83 (SD 0.11) Stage II 0.86 (0.13) Stage III 0.87 (0.08) Stage IV 0.81 (0.11)	SD standard deviation
Schwandner (2013)	EQ-5D	Pre-SNS 0.42 Post-SNS 0.74	SNS sacral nerve stimulation
Sharma (2007)	EQ-5D	Pre-operative 0.8614 (SD 0.16) Post-operative 0.9009 (0.13)	SD standard deviation
Shirowa (2009)	TTO	a) chemotherapy (95% CI) XELOX without AEs 0.59 (0.55-0.64) FOLFOX without AEs 0.53 (0.49-0.57) b) AEs Febrile neutropenia 0.39 (0.36-0.42); Nausea/vomiting 0.38 (0.35-0.42); Diarrhoea 0.42 (0.39-0.45); Hand-foot syndrome 0.39 (0.36-0.42); Fatigue 0.45 (0.41-0.48); Peripheral neuropathy 0.45 (0.41-0.48); Stomatitis 0.42 (0.39-0.45)	AE adverse event CI confidence interval XELOX capecitabine plus oxaliplatin FOLFOX4 5-fluorouracil/folic acid and oxaliplatin
Smith (1993)	TTO	Utility weight [QALY] No recurrence 1.0 [11Y*1=11.0] Recurrence 1.0 [2.25Y*1=2.25] <u>Good chemotherapy scenario:</u> No recurrence 0.93 [14.2Y*0.93=13.2] Recurrence 0.93 [1.45Y*0.93=1.35] <u>Medium chemotherapy scenario:</u> No recurrence 0.88 [14.2Y*0.88=12.5] Recurrence 0.88 [1.45Y*0.88=1.28] <u>Bad chemotherapy scenario:</u> No recurrence 0.80 [14.2Y*0.80=11.4] Recurrence 0.80 [1.45Y*0.80=1.16]	QALY quality-adjusted life year

van den Brink (2004)	EQ-5D	<p><u>PRT + TME</u> Randomisation to PRT or S 0.78 PRT to S 0.70 R0 S to DC 0.11 DC to 4.5m 0.77 (NS) - 0.71 (RS) - 0.83 (DS) - 0.74 (PS) 4.5 to 9m 0.85 (NS) - 0.86 (RS) - 0.78 (DS) - 0.79 (PS) >9months 0.86 (NS - 0.86 (RS) - 0.80 (DS) - 0.85 (PS) R1 S to DC 0.09 DC to 4.5m 0.88 (NS) - 0.73 (RS) - 0.77 (DS) -0.80 (PS) 4.5 to 9m 0.86 (NS) - 0.82 (RS) - 0.81 (DS) - 0.88 (PS) >9m 0.89 (NS) - 0.89 (RS) - 0.75 (DS) - 0.88 (PS) R2 0.73 0.67 (local) Distance (0.70) local and distant (0.48) <u>TME</u> Randomisation to PRT or S 0.78 R0 S to DC 0.21 DC to 4.5m 0.89 (NS) - 0.785(RS) - 0.79 (DS) - 0.80 (PS) 4.5 to 9m 0.90 (NS) - 0.80 (RS) - 0.76 (DS) - 0.85 (PS) >9m 0.86 (NS - 0.86 (RS) - 0.80 (DS) - 0.85 (PS) R1 S to DC 0.17 DC to 4.5m 0.63 (NS) - 0.69 (RS) - 0.76 (DS) -0.88 (PS) 4.5 to 9m 0.85 (NS) - 1.0 (RS) - 0.84 (DS) - 0.86 (PS) >9m 0.89 (NS) - 0.89 (RS) - 0.75 (DS) - 0.88 (PS) R2 0.80 Recurrence 0.80 (local) Distance (0.64) local and distant (0.45)</p>	PRT preoperative radiotherapy TME total mesorectal excision DC discharge m month NS no stoma; RS removed diverting stoma DS diverting stoma; PS permanent stoma R0, R1 and R2 patients with microscopically negative, positive, or incomplete local resection or distant metastases at surgery, respectively S surgery
----------------------	-------	--	---

Table A4.5 Summary of studies reporting HSUVs in CRC			
Author (year)	Measured by	Reported CRC-related utility values	Abbreviations/Keys
Wang (2011)	EQ-5D	Panitumumab plus BSC vs BSC [Q-TWiST] TOX 0.6008 vs 0.4409 TWiST 0.7678 vs 0.6630 REL 0.6318 vs 0.6407	BSC best supportive care TOX days with ≥ grade 3 AEs AE adverse event TWiST time without symptoms or toxicity Q-TWiST quality-adjusted TWiST REL relapse period until death or end of follow-up
Wiering (2010)	EQ-5D	No health states were defined, aggregated QALY for a 3 year follow-up CWU 1.78 (range 0.30-2.76) FDG-PET 1.68 (0.10-2.76) mean difference (95% CI) 0.10 (-0.10/0.39)	QALY quality-adjusted life year CWU conventional diagnostic work-up PDG-PET [F-18]-Fluorodeoxyglucose-positron emission tomography
Wiering (2011)	EQ-5D	Disease-free 0.78 (SD 0.23) Non-curative 0.67 (0.31) Recurrence 0.74 (0.25) Recurrence with CTx - without CTx 0.82 (0.17) - 0.68 (0.28)	CTx chemotherapy
Wilson (2006)	EQ-5D	EQ-5D baseline 0.79 (0.21) <u>With tumor factors</u> Site: colon 0.824 rectal 0.761 Urgency: elective 0.792 acute 0.741 Dukes: A+B 0.786 C+D 0.806 <u>With treatment factors</u> RTx: not given 0.791 given 0.750 Stoma: absent 0.831 present 0.726 Wx: absent 0.799 present 0.699 Other complications: absent 0.781 present 0.812 CTx: not given 0.774 given 0.816 <u>Constipation and diarrhoea</u> Constipation: absent 0.794 mild 0.784 moderate/severe 0.706 diarrhoea: absent 0.81 mild 0.827 moderate/severe 0.585	*HSUVs re-expressed on a 0-1 scale CTx chemotherapy RTx radiotherapy Wx wound infection

Table A4.5 Summary of studies reporting HSUVs in CRC			
Author (year)	Measured by	Reported CRC-related utility values	Abbreviations/Keys
Syngal (1998)	SG	mean (range min-max) subtotal colectomy 0.95 (0.85-1.0) Localized or regional CRC 0.94 (0.90-1.0) Proctocolectomy 0.89 (0.65-1.0) Distant CRC 0.56 (0.30-0.70)	Syngal (1998)
Wong (2012)	FACT-C and FACT-G mapped onto SF-6D	SF6D mean score (\pm SD) 0.825 (\pm 0.136)	SD standard deviation
Wong (2013b)	FACT-C and FACT-G mapped onto SF-6D	LR 0.871 (SD \pm 0.12) HR 0.832 (SD \pm 0.12) Stage I 0.831 (\pm 0.14) Stage II 0.858 (\pm 0.12) Stage III 0.817 (\pm 0.13) Stage IV 0.732 (\pm 0.15)	SD standard deviation LR low-risk polyp HR high-risk polyp
Wong (2014)	SF-6D SF12 to SF6D FACT-C to SF-6D	Baseline; follow-up 6 months (\pm SD) SF6D Direct 0.826(\pm 0.133); 0.807(\pm 0.157) From SF12 to SF-6D 0.815(\pm 0.156); 0.834(\pm 0.172) FACT-C mapped to SF6D 0.824(\pm 0.105); 0.825(\pm 0.139)	SD standard deviation

Table A4.6 Summary of mapping studies

Measuring health		Disease or patient group (number)	Mapping model	Reference
From	To			
FACT-G FACT-C	SF-6D	Patients with LR & HR polyps, stage I II and III CRC (n=552)	OLS	Wong (2012) [226]
FACT-G	EQ-5D	Cancer patients (n=558)	CLAD OLS	Cheung (2009) [235]
FACT-G FACT-C	SF-6D		OLS	Wong (2013b) [190]
FACT-C	SF-6D		OLS (Wong 2012) [226]	Wong (2014) [224]
FACT-G	EQ-5D	Cancer patients (n=472)	Used existing mapping models (Wong 2012, Cheung 2009, Kind 2005)[226, 235, 292]	Pickard (2012) [198]
EORTC QLQ C-30	EQ-5D		OLS	Kim (2012) [229]
SF-36	EQ-5D			Kim (2014) [230]
FACT-C	EQ-5D			Pickard (2012) [198]
SF-36	SF-6D			Lee (2013) [222]
FACT-C	SF-6D		OLS (Wong 2012) [226]	Yang (2014) [225]

CLAD censored least absolute deviation; **CRC** colorectal cancer; **FACT-C** Functional Assessment of Cancer Therapy-Cancer; **FACT-G** Functional Assessment of Cancer Therapy-General; **HR** high-risk **LR** low-risk; **OLS** ordinary least squares

APPENDICES TO CHAPTER 5

Figure A5.1 Reporting form CRCS, NHI (2009)

[별지 제13호의 3서식의 별첨]

대장암 검진 결과 기록지

일반건강검진

생애전환기 건강진단

성명	주민등록번호	-	연락처	
자격구분	<input type="checkbox"/> 건강보험가입자 <input type="checkbox"/> 의료급여수급권자		통보처	국가암보건소 ()
주소	우 - ,			

구분	검사 항목 (검사일 및 검사장소)	검사 결과
대장암	분변잠혈반응검사 년 월 일 <input type="checkbox"/> 내원 <input type="checkbox"/> 출장	<input type="checkbox"/> 정상검사 : 1. 음성 2. 양성 <input type="checkbox"/> 정량검사 : 1. 음성 2. 양성 검사결과: (ng/ml) [기준치: (ng/ml 이하)]
	대장이종 조영검사 년 월 일 내원	판독소견 ※ 최대 3개까지 기입 1. 정상 2. 대장용종 (크기: mm) 3. 대장암 의심 4. 대장암 5. 기타 <input type="checkbox"/> 치핵 <input type="checkbox"/> 비특이성 장염 <input type="checkbox"/> 허혈성 장염 <input type="checkbox"/> 궤양성 대장염 <input type="checkbox"/> 크론병 <input type="checkbox"/> 장결핵 <input type="checkbox"/> 대장 계실증 <input type="checkbox"/> 대장 점막하종양 <input type="checkbox"/> 림프구 증식 <input type="checkbox"/> 직결기입()
	병변위치 ※ 판독소견 필요를 위해서에 따라 필요에 최대 3개까지 기입 대장내시경검사 ※ 결과통보 제외함	1. 회장 말단부 () 2. 맹장 () 3. 상행 결장 () 4. 간 만곡 () 5. 횡행 결장 () 6. 비 만곡 () 7. 하행 결장 () 8. 에스 결장 () 9. 직장 () 10. 항문 ()
	대장 내시경검사 년 월 일 내원	판찰소견 ※ 최대 3개까지 기입 1. 정상 2. 대장용종 (크기: mm/절제치치 <input type="checkbox"/> 실시 <input type="checkbox"/> 미실시) 3. 대장암 의심 4. 대장암 5. 기타 <input type="checkbox"/> 치핵 <input type="checkbox"/> 비특이성 장염 <input type="checkbox"/> 허혈성 장염 <input type="checkbox"/> 궤양성 대장염 <input type="checkbox"/> 크론병 <input type="checkbox"/> 장결핵 <input type="checkbox"/> 대장 계실증 <input type="checkbox"/> 대장 점막하종양 <input type="checkbox"/> 림프구 증식 <input type="checkbox"/> 직결기입()
	병변위치 ※ 판독소견 필요를 위해서에 따라 필요에 최대 3개까지 기입 조직진단 ※ 결과통보 제외함	1. 회장 말단부 () 2. 맹장 () 3. 상행 결장 () 4. 간 만곡 () 5. 횡행 결장 () 6. 비 만곡 () 7. 하행 결장 () 8. 에스 결장 () 9. 직장 () 10. 항문 () 1. 필요 2. 불필요
조직진단 ※ 조직진단 실시하지 않았을 경우 기입 불필요 ※ 조직진단 다수일 경우 가장 중한 진단기입	1. 정상 2. 염증성 또는 증식성 병변 3. 저도선종 또는 이행성 4. 고도선종 또는 이행성 5. 암의심 6. 암 <input type="checkbox"/> 샘암종(고분화, 중분화, 저분화) <input type="checkbox"/> 점액(샘)암종 <input type="checkbox"/> 반지세포암종 <input type="checkbox"/> 샘편평상피암종 <input type="checkbox"/> 편평상피암종 <input type="checkbox"/> 소세포암종 <input type="checkbox"/> 수질암종 <input type="checkbox"/> 미분화 암종 <input type="checkbox"/> 악성림프종 <input type="checkbox"/> 신경내분비종양(맹장과 직장의 1cm이하 종양제외) <input type="checkbox"/> 직결기입() 7. 기타 <input type="checkbox"/> 신경내분비종양 <input type="checkbox"/> 비상피성종양 <input type="checkbox"/> 항문암 <input type="checkbox"/> 말단회장부위 암 <input type="checkbox"/> 직결기입()	

판정 및 권고	판정구분	권고사항
	※ 검사결과에 따라 판정구분이 다수일 경우 가장 중한 판정구분을 기입 1. 음성 2. 양성 또는 1. 정상 2. 양성결환 3. 대장암 의심 4. 대장암 5. 기타 () <input type="checkbox"/> 기존 대장암환자	※ 판정구분에 따른 판정기준 기입 이외에 별도로 300자 이내로 기입
	결과통보일 년 월 일 판정일 년 월 일	판정 의사 면허번호 의사명 (서명)

Figure 5.2 Validation – probability of alive over time in No COL surveillance and general population in Korea

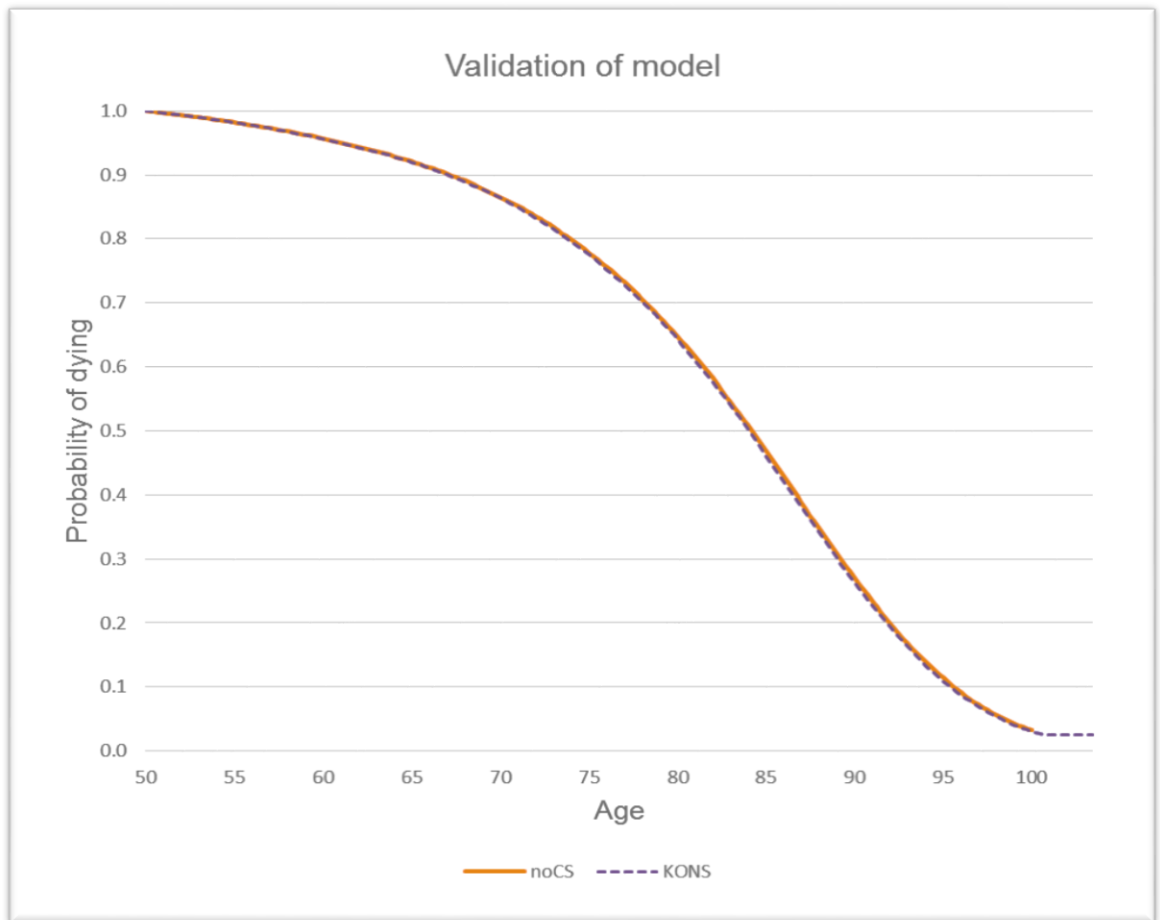

Table A5.1 Steps taken for further search of economic evidence in Korea

Table A5.1.1 Key words, search strategy and selection criteria

Key words	colorectal cancer, screening, polyp, adenoma, cost-effectiveness and cost-utility 비용-효용 분석; 건강상태; 효용; 대장암, 질보정수명, 검진, 용종
Searched databases	National Assembly Library (www.nanet.go.kr), Korean Medical Database (www.kmbase.medic.or.kr), Korean Association of Medical Journal Edition (www.koreamed.org), National Digital Science Library (www.ndsl.kr), Korea Institute of Science and Technology Information (www.kisti.re.kr), Korean Studies information (www.kstudy.com), Korean Medicine Information System (www.kiom.re.kr), Research Information Sharing Service (www.riss.kr). Relevant conference proceedings and abstracts were checked for a full publication and included if relevant. The search was extended to grey literature in order to capture relevant reports commissioned by governmental agencies such as MoHW (www.mw.go.kr), NCC (www.ncc.re.kr), NHIS (www.nhis.or.kr), National Evidence-based Healthcare Collaborating Agency (NECA) (www.neca.re.kr), HIRA (www.hira.or.kr). Supplementary searches including grey literature was conducted in order to identify relevant studies and evidence in a Korean setting.
Selection criteria	Inclusion and exclusion criteria were adopted from Jeong and Cairns (2013). Full economic evaluations considered costs and health outcomes of relevant types of intervention with outcomes expressed in cost per quality-adjusted life-year (QALY) or cost per life-year gained. Burden of disease studies or non-comparative costing studies were included. The population considered was adults with confirmed colorectal adenoma/polyp who are otherwise healthy with no personal or familial history of CRC. Follow-up strategies and screening strategies based on the best available evidence on the screening modalities were considered, including current practice and no intervention. Clinical investigation or therapeutic interventions for suspected CRC or conditions other than colorectal adenoma/polyp were not considered. Any studies which did not assess costs and related health outcomes in line with the research questions were excluded.

Table A5.1.2 Quality assessment of cost-effectiveness studies in Korea

	Park (2004)	Han (2004)	Kim (2004)	Jeong (2008)	Park (2010)
1 Was the research question stated?	Yes	Yes	Yes	Yes	Yes
2 Was the economic importance of the research question stated?	Yes	Yes	Yes	Yes	Yes
3 Was/were the viewpoint(s) of the analysis clearly stated and justified?	Yes	No	No	No	Yes
4 Was a rationale reported for the choice of the alternative programmes or interventions compared?	Yes	Yes	Yes	Yes	Yes
5 Were the alternatives being compared clearly described?	Yes	Yes	Yes	Yes	Yes
6 Was the form of economic evaluation stated?	Yes	Yes	No	No	Yes
7 Was the choice of form of economic evaluation justified in relation to the questions addressed?	Yes	Yes	No	No	Yes
8 Was/were the source(s) of effectiveness estimates used stated?	No	Yes	Yes	Yes	Yes
9 Were details of the design and results of the effectiveness study given (if based on a single study)?	No	No	No	Yes	No
10 Were details of the methods of synthesis or meta-analysis of estimates given (if based on an overview of a number of effectiveness studies)?	No	No	No	Yes	No
11 Was/were the primary outcome measure(s) for the economic evaluation clearly stated?	Yes	Yes	No	Yes	Yes
12 Were the methods used to value health states and other benefits stated?	No	No	No	No	No
13 Were the details of the subjects from whom valuations were obtained given?	No	No	No	No	No
14. Were productivity changes (if included) reported separately?	No	No	No	No	No
15 Was the relevance of productivity changes to the study question discussed?	No	No	No	No	No
16 Were quantities of resources reported separately from their unit cost?	No	No	No	No	No
17 Were the methods for the estimation of quantities and unit costs described?	Yes	Yes	No	No	No
18 Were currency and price data recorded?	Yes	Yes	Yes	Yes	Yes
19 Were details of price adjustments for inflation or currency conversion given?	No	No	No	No	No
20 Were details of any model used given?	Yes	Yes	No	Yes	No

	Park (2004)	Han (2004)	Kim (2004)	Jeong (2008)	Park (2010)
21 Was there a justification for the choice of model used & the key parameters on which it was based?	Yes	Yes	No	No	No
22 Was the time horizon of cost and benefits stated?	Yes	No	No	No	No
23 Was the discount rate stated/justified?	Yes/No	Yes/No	No/No	No/No	No
24 Was an explanation given if cost or benefits were not discounted?	NA	NA	No	No	No
25 Were the details of statistical test(s) and confidence intervals given for stochastic data?	No	No	No	No	No
26 Was the approach to sensitivity analysis described?	Yes	Yes	No	Yes	Yes
27 Was the choice of variables for sensitivity analysis justified?	No	Yes	No	No	Yes
28 Were the ranges over which the parameters were varied stated?	Yes	Yes	No	Yes	Yes
29 Were appropriate comparisons made when conducting the incremental analysis?	Yes	Yes	No	Yes	Yes
30 Was an incremental analysis reported?	Yes	No	No	Yes	Yes
31 Were major outcomes presented in a disaggregated as well as aggregated form?	No	No	No	No	No
32 Was the answer to the study question given?	Yes	Yes	No	No	Yes
33 Did conclusions follow from the data reported?	Yes	Yes	No	Yes	Yes
34 Were conclusions accompanied by the appropriate caveats?	Yes	No	No	No	No
35 Were generalisability issues addressed?	No	No	No	No	No

NA not applicable

Table A5.2 Quality assessment: Whyte (2012) [96]

1. Was the research question stated?	Y
2. Was the economic importance of the research question stated?	Y
3. Was/were the viewpoint(s) of the analysis clearly stated and justified?	Y
4. Was a rationale reported for the choice of the alternative programmes or interventions compared?	Y
5. Were the alternatives being compared clearly described?	Y
6. Was the form of economic evaluation stated?	Y
7. Was the choice of form of economic evaluation justified in relation to the questions addressed?	Y
8. Was/were the source(s) of effectiveness estimates used stated?	Y
9. Were details of the design and results of the effectiveness study given (if based on a single study)?	NA
10. Were details of the methods of synthesis or meta-analysis of estimates given (if based on an overview of a number of effectiveness studies)?	Y
11. Were the primary outcome measure(s) for the economic evaluation clearly stated?	Y
12. Were the methods used to value health states and other benefits stated?	Y
13. Were the details of the subjects from whom valuations were obtained given?	Y
14. Were productivity changes (if included) reported separately?	NA
15. Was the relevance of productivity changes to the study question discussed?	NA
16. Were quantities of resources reported separately from their unit cost?	N
17. Were the methods for the estimation of quantities and unit costs described?	Y
18. Were currency and price data recorded?	Y
19. Were details of price adjustments for inflation or currency conversion given?	N
20. Were details of any model used given?	Y
21. Was there a justification for the choice of model used & the key parameters on which it was based?	Y
22. Was the time horizon of cost and benefits stated?	Y
23. Was the discount rate stated/justified?	Y
24. Was an explanation given if cost or benefits were not discounted?	NA
25. Were the details of statistical test(s) and confidence intervals given for stochastic data?	Y
26. Was the approach to sensitivity analysis described?	Y
27. Was the choice of variables for sensitivity analysis justified?	Y
28. Were the ranges over which the parameters were varied stated?	Y
29. Were appropriate comparisons made when conducting the incremental analysis?	Y
30. Was an incremental analysis reported?	Y
31. Were major outcomes presented in a disaggregated as well as aggregated form?	Y
32. Was the answer to the study question given?	Y
33. Did conclusions follow from the data reported?	Y
34. Were conclusions accompanied by the appropriate caveats?	Y
35. Were generalisability issues addressed?	P

N no; **NA** not applicable; **P** partly; **Y** yes

Table A5.3 Comparison of CRC stage using different classification system (KAMS 2012, Ruh 2016, Walters 2013) [91-93]

CRC stage	T	N	M	SEER		Dukes	Estimated CRC stages, CRC cohort
0	Tis	N0	M0	LOC	0	-	DA
I	T1	N0	M0	LOC	1	A	DA
I	T2	N0	M0	LOC	1	A	DA
IIA	T3	N0	M0	REG	2	B	DB
IIB	T4a	N0	M0	REG	2	B	DB
IIC	T4b	N0	M0	REG	2	B	DB
IIIA	T1-2	N1/N1c	M0	REG	3	C	DC
	T1	N2a	M0	DIS	3	C	DC
IIIB	T3-4a	N1/N1c	M0	REG	4/5	C	DC
	T2-T3	N2a	M0	REG	5	C	DC
	T1-T2	N2b	M0	REG	5	C	DC
IIIC	T4a	N2a	M0	REG	5	C	DC
	T3-T4a	N2b	M0	DIS	7	C	DC
	T4b	N1-N2	M0	DIS	7	C	DC
IVA	Any T	Any N	M1a	DIS	7	-	DD
IVB	Any T	Any N	M1b	DIS	7	-	DD

CRC colorectal cancer; **CRCS** colorectal cancer screening; **DA** Dukes A; **DB** Dukes' B; **DC** Dukes' C; **DD** stage D CRC; **DIS** distant cancer; **LOC** localised cancer; **M** distant metastasis; **M0** no distant metastasis; **M1** distant metastasis; **M1a** metastasis confined to one organ or site (for example, liver, lung, ovary, nonregional node); **M1b** metastases in more than one organ/site or the peritoneum **T** primary tumour; ; **N** regional lymph nodes; **N0** no regional lymph node metastasis; **N1** metastasis in 1-3 regional lymph nodes; **N1a** Metastasis in one regional lymph node; **N1b** metastasis in 2–3 regional lymph nodes; **N1c** tumour deposit(s) in the subserosa, mesentery, or nonperitonealized pericolonic or perirectal tissues without regional nodal metastasis; **N2** metastasis in 4 or more regional lymph nodes; **N2a** metastasis in 4–6 regional lymph nodes; **N2b** metastasis in 7 or more regional lymph nodes; **NCC** National Cancer Centre; **NCSP** National Cancer Screening Programme; **REG** regional cancer; **SEER** Surveillance, Epidemiology, and End Results; **Tis** carcinoma in situ; **T1** tumour invades submucosa; **T2** tumour invades muscularis propria; **T3** tumour invades through the muscularis propria into the pericorectal tissues; **T4** tumour penetrates to the surface of the visceral peritoneum or directly invades or is adherent to other organs or structures
SEER code 0 In situ ; **1** Localized only ; **2** Regional by direct extension only ; **3** Regional lymph nodes involved only; **4** Regional by BOTH direct extension AND lymph node involvement ; **5** Regional, NOS (Not Otherwise Specified); **7** Distant site(s)/node(s) involved; **9** Unknown if extension or metastasis (unstaged, unknown, or unspecified);
 Death certification only case

Table A5.4 Fixed transition probabilities

Table A5.4.1 Adenoma recurrence (subgroup of CRC cohort, n=132,422)

From	To	Incidence	Follow up
AF_LRpp	LR at year 1	85	8832
AF_LRpp	LR at year 2+	282	8547
AF_HRpp	LR at year 1	6	1172
AF_HRpp	LR at year 2+	17	1162
AF_LRpp	AF at year 1	8746	8832
AF_LRpp	AF at year 2+	8256	8547
AF_HRpp	AF at year 1	1162	1172
AF_HRpp	AF at year 2+	1138	1162

AF adenoma free; **AF_LRpp year1** adenoma free post-polypectomy of low-risk adenomas at year 1; **AF_LRpp year 2+** adenoma free post-polypectomy of low-risk adenomas at year 2 or more years; **AF_HRpp year 1** adenoma free post-polypectomy of high-risk adenomas at year 1; **AF_HRpp year 2+** adenoma free post-polypectomy of high-risk adenomas 2 or more years; HR high-risk; LR low-risk

Table A5.4.2 Fixed annual transition probabilities (CRC cohort, Whyte 2012)

	AF	LR	HR	DA	DB	DC	DD	CRC death
AF (LRpp) yr1	#	0.0096	0	0	0	0	0	0
AF (LRpp) yr2+	#	0.0330	0	0	0	0	0	0
AF (HRpp) yr1	#	0.0051	0	0	0	0	0	0
AF (HRpp) yr2+	#	0.0146	0	0	0	0	0	0
LR	0	#	0.008	0	0	0	0	0
HR	0	0	#	0.0250	0	0	0	0
DA	0	0	0	#	0.5100	0	0	0
DB	0	0	0	0	#	0.6900	0	0.0100
DC	0	0	0	0	0	#	0.7100	0.0602
DD	0	0	0	0	0	0	#	0.3867

AF adenoma free; **AF(LRpp) year1** adenoma free post-polypectomy of low-risk adenomas at year 1; **AF(LRpp) year 2+** adenoma free post-polypectomy of low-risk adenomas at year 2 or more years; **AF(HRpp) year 1** adenoma free post-polypectomy of high-risk adenomas at year 1; **AF(HRpp) year 2+** adenoma free post-polypectomy of high-risk adenomas 2 or more years; **CRC** colorectal cancer; **CRC death** death due to CRC; **DA** Dukes' A CRC; **DB** Dukes' B CRC; **DC** Duke's C CRC; **DD** Dukes' D CRC; **HR** high-risk; **LR** low-risk; **#** 1 minus other states

Table A5.4.3 Fixed 3-monthly transition probabilities (CRC cohort, Whyte 2012)

	AF	LR	HR	DA	DB	DC	DD	CRC death
AF (LRpp) yr1	#	0.0024	0	0	0	0	0	0
AF (LRpp) yr2+	#	0.0082	0	0	0	0	0	0
AF (HRpp) yr1	#	0.0013	0	0	0	0	0	0
AF (HRpp) yr2+	#	0.0037	0	0	0	0	0	0
LR	0	#	0.0020	0	0	0	0	0
HR	0	0	#	0.0063	0	0	0	0
DA	0	0	0	#	0.1633	0	0	0
DB	0	0	0	0	#	0.2538	0	0.0025
DC	0	0	0	0	0	#	0.2662	0.0154
DD	0	0	0	0	0	0	#	0.1151

AF adenoma free; **AF(LRpp) year1** adenoma free post-polypectomy of low-risk adenomas at year 1; **AF(LRpp) year 2+** adenoma free post-polypectomy of low-risk adenomas at year 2 or more years; **AF(HRpp) year 1** adenoma free post-polypectomy of high-risk adenomas at year 1; **AF(HRpp) year 2+** adenoma free post-polypectomy of high-risk adenomas 2 or more years; **CRC** colorectal cancer; **CRC death** death due to CRC; **DA** Dukes' A CRC; **DB** Dukes' B CRC; **DC** Duke's C CRC; **DD** Dukes' D CRC; **HR** high-risk; **LR** low-risk; **#** 1 minus other states

Table 5.5 Steps taken to make the economic model probabilistic [271]

Table A5.5.1 Posterior distribution parameters (yearly)

	AF	LR	HR	DA	DB	DC	DD	CRC death
AF (LRyr1)	99.03	0.96	0	0	0	0	0	0
AF (LRyr2+)	96.6	3.3	0	0	0	0	0	0
AF (HRyr1)	99.15	0.51	0	0	0	0	0	0
AF (HRyr2+)	97.93	1.46	0	0	0	0	0	0
LR	0	99.2	0.8	0	0	0	0	0
HR	0	0	97.5	2.5	0	0	0	0
DA	0	0	0	49.0	51.0	0	0	0
DB	0	0	0	0	30.0	69.12	0	1.0
DC	0	0	0	0	0	22.98	71.0	6.02
DD	0	0	0	0	0	0	61.33	38.67

AF adenoma free; **AF(LRpp) year1** adenoma free post-polypectomy of low-risk adenomas at year 1; **AF(LRpp) year 2+** adenoma free post-polypectomy of low-risk adenomas at year 2 or more years; **AF(HRpp) year 1** adenoma free post-polypectomy of high-risk adenomas at year 1; **AF(HRpp) year 2+** adenoma free post-polypectomy of high-risk adenomas 2 or more years; **CRC** colorectal cancer; **CRC death** death due to CRC; **DA** Dukes' A CRC; **DB** Dukes' B CRC; **DC** Duke's C CRC; **DD** Dukes' D CRC; **HR** high-risk; **LR** low-risk

Table A5.5.2 Posterior distribution probabilities (yearly)

	AF	LR	HR	DA	DB	DC	DD	CRC death
AF (LRyr1)	0.9904	0.0096	0	0	0	0	0	0
AF (LRyr2+)	0.9670	0.0330	0	0	0	0	0	0
AF (HRyr1)	0.9949	0.0051	0	0	0	0	0	0
AF (HRyr2+)	0.9853	0.0147	0	0	0	0	0	0
LR	0	0.992	0.008	0	0	0	0	0
HR	0	0	0.975	0.025	0	0	0	0
DA	0	0	0	0.49	0.51	0	0	0
DB	0	0	0	0	0.3	0.69	0	0.01
DC	0	0	0	0	0	0.2298	0.71	0.0602
DD	0	0	0	0	0	0	0.6133	0.3867

AF adenoma free; **AF(LRpp) year1** adenoma free post-polypectomy of low-risk adenomas at year 1; **AF(LRpp) year 2+** adenoma free post-polypectomy of low-risk adenomas at year 2 or more years; **AF(HRpp) year 1** adenoma free post-polypectomy of high-risk adenomas at year 1; **AF(HRpp) year 2+** adenoma free post-polypectomy of high-risk adenomas 2 or more years; **CRC** colorectal cancer; **CRC death** death due to CRC; **DA** Dukes' A CRC; **DB** Dukes' B CRC; **DC** Duke's C CRC; **DD** Dukes' D CRC; **HR** high-risk; **LR** low-risk

Table A5.5.3 Random Dirichlet probabilities (yearly)

	AF	LR	HR	DA	DB	DC	DD	CRC death
AF (LRpp) year 1	#	0.00960	0	0	0	0	0	0
AF (LRpp) year2+	#	0.03303	0	0	0	0	0	0
AF (HRpp) year1	#	0.00512	0	0	0	0	0	0
AF (HRpp) year2+	#	0.01469	0	0	0	0	0	0
LR	0	0.99200	0.0080	0	0	0	0	0
HR	0	0	#	0.0250	0	0	0	0
DA	0	0	0	#	0.5100	0	0	0
DB	0	0	0	0	#	0.6900	0	0.0100
DC	0	0	0	0	0	#	0.7100	0.0602
DD	0	0	0	0	0	0	#	0.3867

AF adenoma free; **AF(LRpp) year1** adenoma free post-polypectomy of low-risk adenomas at year 1; **AF(LRpp) year 2+** adenoma free post-polypectomy of low-risk adenomas at year 2 or more years; **AF(HRpp) year 1** adenoma free post-polypectomy of high-risk adenomas at year 1; **AF(HRpp) year 2+** adenoma free post-polypectomy of high-risk adenomas 2 or more yearst; **CRC** colorectal cancer; **CRC death** death due to CRC; **DA** Dukes' A CRC; **DB** Dukes' B CRC; **DC** Duke's C CRC; **DD** Dukes' D CRC; **HR** high-risk; **LR** low-risk; **Other death** deaths due to all other causes; # 1 minus other states

Table A5.5.4 Transition probabilities of adenoma-carcinoma (3-monthly)

	AF	LR	HR	DA	DB	DC	DD	CRC death
AF (LRpp) year 1	#	0.0024 1	0	0	0	0	0	0
AF (LRpp) year2+	#	0.0083 6	0	0	0	0	0	0
AF (HRpp) year1	#	0.0012 8	0	0	0	0	0	0
AF (HRpp) year2+	#	0.0036 9	0	0	0	0	0	0
LR	0	#	0.002	0	0	0	0	0
HR	0	0	#	0.0063	0	0	0	0
DA	0	0	0	#	0.1633	0	0	0
DB	0	0	0	0	#	0.2538	0	0.0025
DC	0	0	0	0	0	#	0.2662	0.0154
DD	0	0	0	0	0	0	#	0.1151

AF adenoma free; **AF(LRpp) year1** adenoma free post-polypectomy of low-risk adenomas at year 1; **AF(LRpp) year 2+** adenoma free post-polypectomy of low-risk adenomas at year 2 or more years; **AF(HRpp) year 1** adenoma free post-polypectomy of high-risk adenomas at year 1; **AF(HRpp) year 2+** adenoma free post-polypectomy of high-risk adenomas 2 or more years; **CRC** colorectal cancer; **CRC death** death due to CRC; **DA** Dukes' A CRC; **DB** Dukes' B CRC; **DC** Duke's C CRC; **DD** Dukes' D CRC; **HR** high-risk; **LR** low-risk; **Other death** deaths due to all other causes; # 1 minus other states

Appendix Table A5.6 Steps taken to identify HSUVs of CRC in a Korean context

Table A5.6.1 Further search for HSUVs in a Korean context

Key words	Health state utility value; colorectal cancer; quality-adjusted life year (QALY); economic evaluation; 비용-효용 분석; 건강상태; 효용; 대장암, 질보정수명
Searched databases	National Assembly Library (www.nanet.go.kr), Korean Medical Database (www.kmbase.medric.or.kr), Korean Association of Medical Journal Edition (www.koreamed.org), National Digital Science Library (www.ndsl.kr), Korea Institute of Science and Technology Information (www.kisti.re.kr), Korean Studies information (www.kstudy.com), Korean Medicine Information System (www.kiom.re.kr), Research Information Sharing Service (www.riss.kr). The search was extended to grey literature in order to capture relevant reports commissioned by governmental agencies such as MoHW (www.mw.go.kr), National Cancer Centre (NCC) (www.ncc.re.kr), NHIS (www.nhis.or.kr), National Evidence-based Healthcare Collaborating Agency (NECA) (www.neca.re.kr), Health Insurance Review & Assessment (HIRA) (www.hira.or.kr)
Selection criteria	Relevant conference proceedings and abstracts were checked for a full publication and included if relevant. Full text was acquired for the remaining studies (including those which had insufficient details, such as no abstract). Studies were included if they contained CRC-related HSUVs which had not been previously reported, be they generic PBMs or directly valued CRC-related health state descriptions, or mapping to generic PBMs based on direct statistical association mapping

Table A5.6.2 Studies identified for full-text review

1	Min, H. and J. Kim, <i>Health-related Quality of Life of Patients with Rectal Cancer</i> . J Korean Soc Coloproctol, 2009. 25 (2): p. 100-106.
2	Kim, J., et al., <i>항암화학요법으로 인한 말초신경병증을 경험하는 대장암 환자의 삶의 질</i> . 중앙간호학회지 Journal of Korean oncology nursing, 2011. 11 (3): p. 254-262.
3	Jeong, J., et al., <i>Related Factors to Quality of Life among Hospitalized Cancer Patients Undergoing Chemotherapy</i> . Asian Oncology Nursing, 2012. 12 (1): p. 84-91.
4	Jeong, G., K. Kim, and Y. Kwak, <i>대장암 환자 증상군의 중증도에 따른 삶의 질</i> Quality of Life in Colorectal Cancer Patients according to the Severity of Symptom Clusters Classification. Asian Oncology Nursing, 2014. 14 (2): p. 74-83.
5	Byun, H.S., et al., <i>입원 암환자의 피로와 삶의 질</i> . 한국호스피스 & 완화의료학회지 Korean journal of hospice and palliative care, 2010. 13 (2): p. 98-108.
6	Choi, H.J., J. Park, and J.H. Lee, <i>대장암 환자의 증상경험과 극복력이 삶의 질에 미치는 효과</i> . Asian Oncology Nursing, 2012. 12 (1): p. 61-68.
7	Kim, J.H., <i>장루 복원술을 시행한 대장암 환자의 삶의 질 영향 요인</i> Quality of life and related factors in colorectal cancer patients with stoma reversal in Graduate School of Nursing. 2014, Hallym University: Korea. p. 61.
8	Kim, S.H., et al., <i>Deriving a mapping algorithm for converting SF-36 scores to EQ-5D utility score in a Korean population</i> . Health and Quality of Life Outcomes, 2014. 12 (1): p. 1-10.
9	Kim, S.H., et al., <i>Validity and reliability of the EQ-5D for cancer patients in Korea</i> . Support Care Cancer, 2012a. 20 (12): p. 3155-60.
10	Kim, S.H., et al., <i>Mapping EORTC QLQ-C30 onto EQ-5D for the assessment of cancer patients</i> . Health Qual Life Outcomes, 2012b. 10 : p. 151.

Table A5.6.3 Ordinary least square regression model (Kim 2012b)

		B	Standard error	P value
Intercept	_cons	0.53897	0.03507	<0.0001
Global health status	global	0.00092	0.00018	<0.0001
5 functional scales	F_			
Physical	F_phy	0.00223	0.00027	<0.0001
Role	F_role	0.00065	0.00019	0.001
Emotional	F_emo	0.00038	0.00021	0.071
Eognitive	F_cog	0.00015	0.00021	0.474
Social	F_soc	0.0002	0.00017	0.234
3 symptom scales	S_			
fatigue	S_fat	0.00042	0.00027	0.111
nausea or vomitting	S_nau	-0.00005	0.00015	0.737
pain	S_pain	-0.00123	0.00017	<0.0001
6 single items				
Dyspnea	dysp	-0.00024	0.00015	0.102
Insomnia	inso	-0.00009	0.00013	0.494
Appetite loss	apploss	-0.00001	0.00014	0.943
Constipation	consti	-0.00004	0.00012	0.72
Diarroea	diarr	0.00005	0.00013	0.72
Financial difficulties	fdiff	0.00005	0.00012	0.673

Table A5.6.4 Summary statistics and mapped HSUVs

Characteristics	Mean (\pmSD), frequency (%)	Mapped HSUVs	Reference
Sample size	N=93 (male n=53, 57%)	NA	Kim JH (2011) [286]
Age	55.75 (\pm 9.07)	NA	Kim JH (2011) [286]
CRC stage I	0 (0.0)	0.662	<i>Assumption</i>
CRC stage II	7 (7.5%)	0.662	Kim JH (2011), Kim SH (2012b) [229, 286]
CRC stage III	22 (23.7%)	0.668	Kim JH (2011), Kim SH (2012b) [229, 286]
CRC stage IV	64 (68.8%)	0.667	Kim JH (2011), Kim SH (2012b) [229, 286]

CRC colorectal cancer; **HSUV** health state utility value; **NA** not applicable; **SD** standard deviation

Table A5.7 Resources associated with COL and CRC in the NHI

Table A5.7.1 Summary of unit costs of COL surveillance and CRC diagnosis

(Unit: KRW; KRW 1,000=GBP 0.56)

Description	Reimbursement NHI (2015)
COL	74,240
Bowel preparation for COL	8,400
Biopsy during COL	12,740
Pathology	
1-3 pieces	20,390
4-6 pieces	27,470
7-9 pieces	34,560
10-12 pieces	42,530
13 and more	49,620
Outpatient clinic visits for consultation (initial and 3 follow-up visits)	9,479
Histopathology	40,437
Routine blood tests, complete blood count with platelet, chemistry and CEA	16,255
Colonoscopy in case of incomplete previous colonoscopy	74,240
Intravenous contrast-enhanced abdomen and pelvis CT	
Chest x-ray	
Chest CT for lung metastasis	
PET-CT when metastasis is suspected	260,135
Abdomen (MRI)	277,018
Bone scan	76,062
Ultrasound sonography	44,120

CEA carcinoembryonic antigen; **COL** colonoscopy; **CRC** colorectal cancer; **CT** computed tomography; **GBP** Great British Pound; **KRW** Korean Won; **MRI** magnetic resonance imaging; **PET** position emission tomography

Table A5.7.2 Summary of recommended chemotherapy agents for CRC

Primary chemotherapy agents	Indications	Reference
Fluorouracil + leucovorin	Clinician's judgement	HIRA (2014)
Fluorouracil + cisplatin	Clinician's judgement	HIRA (2014)
Fluorouracil + leucovorin + cisplatin	Clinician's judgement	HIRA (2014)
Fluorouracil + leucovorin + carboplatin	Clinician's judgement	HIRA (2014)
Tegafur + uracil + leucovorin (oral)	Clinician's judgement	HIRA (2014)
leucovorin (oral)	Clinician's judgement	HIRA (2014)
Tegafur + uracil + leucovorin (oral) + cisplatin	Clinician's judgement	HIRA (2014)
leucovorin (oral) + cisplatin	Clinician's judgement	HIRA (2014)
Mitomycin C	Clinician's judgement	HIRA (2014)
Mitomycin C + leucovorin (oral)	Clinician's judgement	HIRA (2014)
Mitomycin C + tegafur + uracil + leucovorin (oral)	Clinician's judgement	HIRA (2014)
Cisplatin	Clinician's judgement	HIRA (2014)
Etoposide (intravenous or oral)	Clinician's judgement	HIRA (2014)
Secondary chemotherapy agents		HIRA (2014)
Neoadjuvant		HIRA (2014)
Capecitabine + radiotherapy	CRC Stages II & III	HIRA (2014)
Oxaliplatin + leucovorin + infusional fluorouracil (FOLFOX)	CRC stage II (post-operative) CRC stage III	HIRA (2014)
Capecitabine	CRC stage II (post-operative) CRC stage III	HIRA (2014)
Oxaliplatin + capecitabine	CRC stage III	HIRA (2014)
Palliative		
Irinotecan + leucovorin fluorouracil (infusion)(FOLFIRI) + bevacizumab	Metastasis	HIRA (2014)
Irinotecan + leucovorin + fluorouracil (infusion) (FOLFIRI) + cetuximab	EGFR positive, KRAS wild-type metastatic CRC	HIRA (2014)
Irinotecan + leucovorin + fluorouracil (infusion) (FOLFIRI) + bevacizumab	Metastasis	HIRA (2014)
Oxaliplatin + leucovorin + fluorouracil (infusion) (FOLFOX) + bevacizumab	Metastasis	HIRA (2014)

CRC colorectal cancer; **EGFR** epidermal growth factor receptor; **KRAS** mutations in the Kirsten Ras gene

Table A5.8 Annual average OOP payments between people with and without cancer in Korea (Seo 2013) [284]

(Unit: KRW; KRW 1,000=GBP 0.56)

		2009			2010			2011		
		Average	SD	%	Average	SD	%	Average	SD	%
Without cancer	Emergency	4,841	34,899	1.3	5,610	58,922	1.4	4,696	33,066	1.1
	Hospital stay	96,508	603,044	25.8	102,047	641,365	25.0	117,756	970,279	26.4
	Outpatient clinic	215,545	581,167	57.5	233,240	614,434	57.2	251,483	620,185	56.3
	Pharmacy prescription	55,534	133,473	14.8	62,807	146,481	15.4	68,147	161,528	15.3
	Carers costs	2,314	77,940	0.6	4,065	125,738	1.0	4,605	128,241	1.0
	Total	374,742		100	407,769		100	446,687		100
Cancer	Emergency	13,904	77,874	0.8	15,697	110,287	0.9	15,537	57,254	0.8
	Hospital stay	924,635	1,853,974	54.4	899,139	1,860,753	49.9	1,134,263	2,185,250	55.3
	Outpatient clinic	597,448	775,403	35.1	690,775	972,270	38.3	697,575	918,968	34.0
	Pharmacy prescription	152,288	276,796	9.0	175,817	383,616	9.7	185,790	401,160	9.0
	Carers costs	12,245	142,681	0.7	22,195	200,763	1.2	16,962	185,672	0.8
		1,700,520		100	1,803,623		100	2,050,127		100

GBP Great British pound; **KRW** Korean Won; **OOP** out-of-pocket payment; **SD** standard deviation

Table A5.9 Description of SEER and the partial adoption of SEER in CRCS

SEER	Description	Reported SEER codes in CRCS	CRC stages in the model
0	In situ	Not specified	Dukes' A
1	Localised only	1	Dukes' A
2	Regional by direct extension only	2	Dukes' B Dukes' C
3	Regional lymph nodes involved only	Not specified	
4	Regional by BOTH direct extension AND lymph node involvement	Not specified	
5	Regional, NOS (Not Otherwise Specified)	Not specified	
7	Distant site(s)/node(s) involved	7	Dukes' D
9	Unknown if extension or metastasis (unknown, or unspecified)	9	

SEER Surveillance, Epidemiology and End Results; **CRC** colorectal cancer; **CRCS** colorectal cancer screening

Table A5.10 Summary of recommended chemotherapy agents for CRC [282]

Primary chemotherapy agents	Indications
Fluorouracil + leucovorin	Clinician's judgement
Fluorouracil + cisplatin	Clinician's judgement
Fluorouracil + leucovorin + cisplatin	Clinician's judgement
Fluorouracil + leucovorin + carboplatin	Clinician's judgement
Tegafur + uracil + leucovorin (oral)	Clinician's judgement
leucovorin (oral)	Clinician's judgement
Tegafur + uracil + leucovorin (oral) + cisplatin	Clinician's judgement
leucovorin (oral) + cisplatin	Clinician's judgement
Mitomycin C	Clinician's judgement
Mitomycin C + leucovorin (oral)	Clinician's judgement
Mitomycin C + tegafur + uracil + leucovorin (oral)	Clinician's judgement
Cisplatin	Clinician's judgement
Etoposide (intravenous or oral)	Clinician's judgement
Secondary chemotherapy agents	
Neoadjuvant	
Capecitabine + radiotherapy	CRC Stages II & III
Oxaliplatin + leucovorin + infusional fluorouracil (FOLFOX)	CRC stage II (post-operative) CRC stage III
Capecitabine	CRC stage II (post-operative) CRC stage III
Oxaliplatin + capecitabine	CRC stage III
Palliative	
Irinotecan + leucovorin + fluorouracil (infusion)(FOLFIRI) + bevacizumab	Metastasis
Irinotecan + leucovorin + fluorouracil (infusion) (FOLFIRI) + cetuximab	EGFR positive, KRAS wild-type metastatic CRC
Irinotecan + leucovorin + fluorouracil (infusion) (FOLFIRI) + bevacizumab	Metastasis
Oxaliplatin + leucovorin + fluorouracil (infusion) (FOLFOX) + bevacizumab	Metastasis

CRC colorectal cancer; **EGFR** epidermal growth factor receptor; **KRAS** mutations in the Kirsten Ras gene

Table A5.11 Summary costs of chemotherapy, CRC treatment (source: CRC cohort)

(Unit: KRW; KRW 1,000=GBP 0.56)

NHI Code	Description	Average cost
KK 153, KK154	Chemotherapy Administration-Continuous Intravenous	4,170
HE427, HE 427001, HE427006, HE427007, HE427300, HE427306, HE427307	Abdomen MRI (limited) in deciding therapeutic range and location of radiotherapy	86,605
Q2671, Q2672, Q2673, Q2679, Q2680, Q2921-Q2927	Surgeries relevant to CRC treatment: total colectomy, colectomy – segmental resection, rectal and sigmoid resection, intestinal anastomosis, hemi-colectomy, colectomy with proximal colostomy and distal stump, Colonoscopic operation of colonic tumor-mucosal resection and submucosal resection	373,038
L01010101	Intravenous general anaesthesia	62,159

CRC colorectal cancer; **KRW** Korean Won; **GBP** Great British pound; **MRI** magnetic resonance imaging

Table A5.12 Costs of radiation therapy for CRC (CRC cohort)

(Unit: KRW; KRW 1,000=GBP 0.56)

Codes	Description	Average cost
HD051-HD056	Teletherapy	28,378
HD057-HD059	Rotational irradiation	38,845
HD061	3-dimensional conformal therapy	152,490
HD071-HD073	Unsealed sources	36,265
HD080-HD088	Brachytherapy	2,097,480
HD091-HD092	Total body irradiation	233,060
HD093	Total skin electron beam therapy	403,665
HD110	Fractionated stereotactic radiotherapy	547,915
HD111, HD112, HD212	Body stereotactic radiosurgery	529,565
HD121	Proton therapy	513,235
HZ271	Intensity modulated radiation therapy	297,645

KRW Korean Won; **GBP** Great British pound

Table A5.13 Validation of model - probability of being alive from age 50-100

Age	No COL surveillance	KONS (2015)	Age	No COL surveillance	KONS (2015)
	1.0000	1.0000	62.75	0.9369	0.9358
50	0.9992	0.9992	63.00	0.9349	0.9339
50.25	0.9984	0.9984	63.25	0.9330	0.9320
50.50	0.9976	0.9976	63.50	0.9311	0.9301
50.75	0.9969	0.9968	63.75	0.9292	0.9281
51.00	0.9960	0.9959	64.00	0.9271	0.9260
51.25	0.9952	0.9951	64.25	0.9250	0.9239
51.50	0.9943	0.9942	64.50	0.9230	0.9219
51.75	0.9935	0.9933	64.75	0.9209	0.9196
52.00	0.9925	0.9924	65.00	0.9186	0.9174
52.25	0.9916	0.9915	65.25	0.9164	0.9151
52.50	0.9907	0.9906	65.50	0.9141	0.9129
52.75	0.9898	0.9896	65.75	0.9118	0.9104
53.00	0.9888	0.9886	66.00	0.9093	0.9079
53.25	0.9879	0.9877	66.25	0.9068	0.9055
53.50	0.9869	0.9867	66.50	0.9043	0.9030
53.75	0.9859	0.9857	66.75	0.9019	0.9003
54.00	0.9849	0.9846	67.00	0.8991	0.8975
54.25	0.9839	0.9836	67.25	0.8964	0.8948
54.50	0.9828	0.9826	67.50	0.8936	0.8921
54.75	0.9818	0.9815	67.75	0.8909	0.8891
55.00	0.9807	0.9804	68.00	0.8879	0.8861
55.25	0.9796	0.9793	68.25	0.8849	0.8832
55.50	0.9786	0.9782	68.50	0.8819	0.8802
55.75	0.9775	0.9771	68.75	0.8789	0.8769
56.00	0.9763	0.9759	69.00	0.8756	0.8737
56.25	0.9752	0.9748	69.25	0.8723	0.8704
56.50	0.9740	0.9736	69.50	0.8690	0.8672
56.75	0.9729	0.9724	69.75	0.8658	0.8636
57.00	0.9716	0.9712	70.00	0.8621	0.8600
57.25	0.9704	0.9699	70.25	0.8585	0.8565
57.50	0.9692	0.9687	70.50	0.8550	0.8530
57.75	0.9679	0.9674	70.75	0.8514	0.8490
58.00	0.9666	0.9661	71.00	0.8474	0.8451
58.25	0.9653	0.9648	71.25	0.8434	0.8412
58.50	0.9640	0.9634	71.50	0.8395	0.8373
58.75	0.9627	0.9620	71.75	0.8356	0.8329
59.00	0.9612	0.9606	72.00	0.8312	0.8286
59.25	0.9598	0.9591	72.25	0.8269	0.8243
59.50	0.9584	0.9577	72.50	0.8225	0.8201
59.75	0.9569	0.9562	72.75	0.8182	0.8154
60.00	0.9554	0.9546	73.00	0.8135	0.8107
60.25	0.9538	0.9531	73.25	0.8087	0.8060
60.50	0.9523	0.9515	73.50	0.8040	0.8013
60.75	0.9507	0.9499	73.75	0.7994	0.7962
61.00	0.9491	0.9482	74.00	0.7942	0.7911
61.25	0.9474	0.9465	74.25	0.7890	0.7860
61.50	0.9457	0.9449	74.50	0.7839	0.7810
61.75	0.9440	0.9431	74.75	0.7788	0.7754
62.00	0.9422	0.9413	75.00	0.7732	0.7699
62.50	0.9387	0.9377	75.25	0.7677	0.7644

Age	No COL surveillance	KONS (2015)	Age	No COL surveillance	KONS (2015)
75.50	0.7621	0.7589	87.75	0.3482	0.3408
75.75	0.7566	0.7529	88.00	0.3379	0.3308
76.00	0.7506	0.7469	88.25	0.3278	0.3210
76.25	0.7445	0.7410	88.50	0.3181	0.3115
76.50	0.7385	0.7351	88.75	0.3087	0.3014
76.75	0.7326	0.7285	89.00	0.2986	0.2917
77.00	0.7260	0.7220	89.25	0.2889	0.2822
77.25	0.7195	0.7156	89.50	0.2795	0.2731
77.50	0.7130	0.7092	89.75	0.2704	0.2634
77.75	0.7066	0.7021	90.00	0.2608	0.2541
78.00	0.6995	0.6951	90.25	0.2515	0.2451
78.25	0.6924	0.6881	90.50	0.2425	0.2364
78.50	0.6854	0.6813	90.75	0.2339	0.2273
78.75	0.6785	0.6736	91.00	0.2248	0.2185
79.00	0.6708	0.6661	91.25	0.2161	0.2101
79.25	0.6633	0.6586	91.50	0.2077	0.2020
79.50	0.6558	0.6512	91.75	0.1997	0.1935
79.75	0.6483	0.6431	92.00	0.1913	0.1854
80.00	0.6402	0.6350	92.25	0.1832	0.1776
80.25	0.6321	0.6271	92.50	0.1755	0.1701
80.50	0.6241	0.6192	92.75	0.1681	0.1624
80.75	0.6162	0.6105	93.00	0.1604	0.1550
81.00	0.6075	0.6020	93.25	0.1531	0.1480
81.25	0.5989	0.5935	93.50	0.1461	0.1413
81.50	0.5904	0.5852	93.75	0.1394	0.1343
81.75	0.5821	0.5760	94.00	0.1326	0.1277
82.00	0.5729	0.5669	94.25	0.1260	0.1215
82.25	0.5638	0.5580	94.50	0.1198	0.1155
82.50	0.5549	0.5493	94.75	0.1139	0.1094
82.75	0.5461	0.5396	95.00	0.1079	0.1036
83.00	0.5364	0.5301	95.25	0.1022	0.0981
83.25	0.5269	0.5208	95.50	0.0967	0.0930
83.50	0.5176	0.5116	95.75	0.0916	0.0877
83.75	0.5084	0.5015	96.00	0.0864	0.0827
84.00	0.4983	0.4916	96.25	0.0815	0.0780
84.25	0.4883	0.4818	96.50	0.0768	0.0736
84.50	0.4786	0.4723	96.75	0.0725	0.0691
84.75	0.4691	0.4619	97.00	0.0680	0.0649
85.00	0.4587	0.4518	97.25	0.0639	0.0610
85.25	0.4486	0.4418	97.50	0.0600	0.0573
85.50	0.4386	0.4321	97.75	0.0563	0.0536
85.75	0.4289	0.4216	98.00	0.0527	0.0501
86.00	0.4185	0.4114	98.25	0.0493	0.0469
86.25	0.4082	0.4014	98.50	0.0461	0.0438
86.50	0.3982	0.3916	98.75	0.0431	0.0408
86.75	0.3885	0.3811	99.00	0.0401	0.0380
87.00	0.3780	0.3709	99.25	0.0373	0.0354
87.25	0.3678	0.3609	99.50	0.0347	0.0329
87.50	0.3579	0.3512	99.75	0.0323	0.0307

Tables A5.14 Full results of sensitivity analyses

Table A5.14.1 Discount at 0%

	Cost	QALY	inc Cost	inc QALY	ICER
No_COL	2818	10.86598			
0LR3HR	5750	10.92539	2932	0.05941	49346
0LR2HR	5991	10.92534	241	-0.00005	Dominated by 0LR3HR
0LR1HR	6250	10.92532	259	-0.00002	Dominated by 0LR3HR
5LR3HR	41907	10.85894	35657	-0.06638	Dominated by 0LR3HR
5LR2HR	42113	10.85884	206	-0.00010	Dominated by 0LR3HR
5LR1HR	42330	10.85884	217	0.00000	Dominated by 0LR3HR
3LR3HR	49695	10.85652	7365	-0.00232	Dominated by 0LR3HR
3LR1HR	50021	10.85646	325	-0.00006	Dominated by 0LR3HR
1LR1HR	57542	10.85571	7521	-0.00075	Dominated by 0LR3HR

Table 5.14.2 Discount at 3.5%

	Cost	QALY	inc Cost	inc QALY	ICER
No_COL	6533	16.270694			
0LR3HR	9325	16.418176	2793	0.1475	18935
0LR2HR	9463	16.418116	138	-0.0001	Dominated by 0LR2HR
0LR1HR	9607	16.418076	144	0.0000	Dominated by 0LR2HR
5LR3HR	54894	16.254645	45287	-0.1634	Dominated by 0LR2HR
5LR2HR	54927	16.254502	33	-0.0001	Dominated by 0LR2HR
5LR1HR	55007	16.254498	80	0.0000	Dominated by 0LR2HR
3LR3HR	58554	16.250703	3547	-0.0038	Dominated by 0LR2HR
3LR1HR	58573	16.250631	19	-0.0001	Dominated by 0LR2HR
1LR1HR	60600	16.249637	2027	-0.0010	Dominated by 0LR2HR

Table A5.14.3 Discount at 7%

	Cost	QALY	inc Cost	inc QALY	ICER
No_COL	2818	10.86598			
0LR3HR	5750	10.92539	2932	0.05941	49346
0LR2HR	5991	10.92534	241	-0.00005	Dominated by 0LR3HR
0LR1HR	6250	10.92532	259	-0.00002	Dominated by 0LR3HR
5LR3HR	41907	10.85894	35657	-0.06638	Dominated by 0LR3HR
5LR2HR	42113	10.85884	206	-0.00010	Dominated by 0LR3HR
5LR1HR	42330	10.85884	217	0.00000	Dominated by 0LR3HR
3LR3HR	49695	10.85652	7365	-0.00232	Dominated by 0LR3HR
3LR1HR	50021	10.85646	325	-0.00006	Dominated by 0LR3HR
1LR1HR	57542	10.85571	7521	-0.00075	Dominated by 0LR3HR

Table A5.14.4 Transition probability (TP) LR year 1 (0.0024) is assumed to be same as TP at year 2 (0.0084)

	Cost	QALY	inc Cost	inc QALY	ICER
No_COL	4587	13.55879			
0LR3HR	7487	13.66083	2900	0.10204	28419
0LR2HR	7672	13.66073	185	-0.00009	Dominated by 0LR3HR
0LR1HR	7867	13.66067	195	-0.00006	Dominated by 0LR3HR
5LR3HR	49234	13.58028	41367	-0.08039	Dominated by 0LR3HR
5LR2HR	49354	13.57960	120	-0.00069	Dominated by 0LR3HR
5LR1HR	49494	13.57954	140	-0.00005	Dominated by 0LR3HR
3LR3HR	55072	13.56890	5578	-0.01064	Dominated by 0LR3HR
3LR1HR	55224	13.56834	153	-0.00056	Dominated by 0LR3HR
1LR1HR	59813	13.55279	4588	-0.01555	Dominated by 0LR3HR

Table A5.14.5 Transition probability (TP) HR year 1 (0.0012) is assumed to be same as TP at year 2 (0.0037)

	Cost	QALY	inc Cost	inc QALY	ICER
No_COL	4495	13.490150			
0LR3HR	7407	13.588586	2912	0.09844	29585
0LR2HR	7592	13.588540	185	-0.00005	Dominated by 0LR3HR
0LR1HR	7788	13.588518	196	-0.00002	Dominated by 0LR3HR
5LR3HR	48754	13.479301	40966	-0.10922	Dominated by 0LR3HR
5LR2HR	48879	13.479172	125	-0.00013	Dominated by 0LR3HR
5LR1HR	49021	13.479170	142	0.00000	Dominated by 0LR3HR
3LR3HR	54543	13.476035	5522	-0.00313	Dominated by 0LR3HR
3LR1HR	54707	13.475961	165	-0.00007	Dominated by 0LR3HR
1LR1HR	59307	13.475026	4600	-0.00094	Dominated by 0LR3HR

Table A5.14.6 Transition probability (TP) LR year 1 (0.0024) is assumed to be (0.026) (Whyte 2012)

	Cost	QALY	inc Cost	inc QALY	ICER
No_COL	4859	13.76103			
0LR3HR	7742	13.87326	2883	0.11223	25,689
0LR2HR	7927	13.87306	185	-0.00019	Dominated by 0LR3HR
0LR1HR	8122	13.87289	195	-0.00017	Dominated by 0LR3HR
5LR3HR	50749	13.88482	42627	0.01193	3,718,969
5LR2HR	50878	13.88249	129	-0.00234	Dominated by 5LR3HR
5LR1HR	51014	13.88228	136	-0.00020	Dominated by 5LR3HR
3LR3HR	56752	13.85115	5739	-0.03113	Dominated by 5LR3HR
3LR1HR	56883	13.84915	131	-0.00200	Dominated by 5LR3HR
1LR1HR	61447	13.79156	4564	-0.05760	Dominated by 5LR3HR

Table A5.14.7 Transition probability (TP) HR year 1 (0.0012) is assumed to be (0.0026) (Whyte 2012)

	Cost	QALY	inc Cost	inc QALY	ICER
No_COL	4545	13.527115			
0LR3HR	7516	13.626158	2971	0.09904	29,999
0LR2HR	7702	13.626154	186	0.00000	Dominated by 0LR3HR
0LR1HR	7903	13.626185	201	0.00003	Dominated by 0LR3HR
5LR3HR	49156	13.518268	41253	-0.10792	Dominated by 0LR3HR
5LR2HR	49348	13.518020	192	-0.00025	Dominated by 0LR3HR
5LR1HR	49495	13.518040	146	0.00002	Dominated by 0LR3HR
3LR3HR	54978	13.513839	5483	-0.00420	Dominated by 0LR3HR
3LR1HR	55182	13.513676	204	-0.00016	Dominated by 0LR3HR
1LR1HR	59802	13.511995	4621	-0.00168	Dominated by 0LR3HR

Table A5.14.8 Risk stratification – number of adenomas

	Cost	QALY	inc Cost	inc QALY	ICER
No_COL	5041	13.487691			
0LR3HR	7784	13.595716	2742	0.108025	25,386
0LR2HR	7967	13.595641	183	-0.000075	Dominated by 0LR3HR
0LR1HR	8161	13.595591	194	-0.000050	Dominated by 0LR3HR
5LR3HR	49787	13.475612	41626	-0.119980	Dominated by 0LR3HR
5LR2HR	49817	13.475443	30	-0.000169	Dominated by 0LR3HR
5LR1HR	49945	13.475438	128	-0.000005	Dominated by 0LR3HR
3LR3HR	55531	13.472028	5586	-0.003410	Dominated by 0LR3HR
3LR1HR	55578	13.471939	47	-0.000089	Dominated by 0LR3HR
1LR1HR	59779	13.470993	4202	-0.000947	Dominated by 0LR3HR

Table A5.14.9 LR:HR proportion 500:500

	Cost	QALY	inc Cost	inc QALY	ICER
No_COL	3511	13.4834			
0LR3HR	16219	13.5369	12708	0.05356	237,256
0LR2HR	16958	13.5367	739	-0.00021	Dominated by 0LR3HR
0LR1HR	17739	13.5366	781	-0.00011	Dominated by 0LR3HR
5LR3HR	41522	13.4739	23783	-0.06270	Dominated by 0LR3HR
5LR2HR	41650	13.4735	128	-0.00043	Dominated by 0LR3HR
5LR1HR	42365	13.4735	715	0.00000	Dominated by 0LR3HR
3LR3HR	44915	13.4720	2550	-0.00153	Dominated by 0LR3HR
3LR1HR	45698	13.4717	783	-0.00027	Dominated by 0LR3HR
1LR1HR	48507	13.4712	2809	-0.00050	Dominated by 0LR3HR

Table A5.14.10 LR:HR=0:1000

	Cost	QALY	inc Cost	inc QALY	ICER
No_COL	4489	13.48613			
0LR3HR	7395	13.58451	2906	0.0984	29,538
0LR2HR	7580	13.58445	185	-0.0001	Dominated by 0LR3HR
0LR1HR	7775	13.58443	195	0.0000	Dominated by 0LR3HR
5LR3HR	48710	13.47507	40935	-0.1094	Dominated by 0LR3HR
5LR2HR	48827	13.47495	117	-0.0001	Dominated by 0LR3HR
5LR1HR	48969	13.47495	142	0.0000	Dominated by 0LR3HR
3LR3HR	54495	13.47193	5526	-0.0030	Dominated by 0LR3HR
3LR1HR	54656	13.47187	160	-0.0001	Dominated by 0LR3HR
1LR1HR	59253	13.47101	4598	-0.0009	Dominated by 0LR3HR

Table A5.14.11 Mapped HSUVs (Kim SH, 2011)

	Cost	QALY	inc Cost	inc QALY	ICER
No_COL	4378	13.480859			
0LR3HR	7293	13.558066	2915	0.07721	37,753
0LR2HR	7478	13.558018	185	-0.00005	Dominated by 0LR3HR
0LR1HR	7673	13.557997	195	-0.00002	Dominated by 0LR3HR
5LR3HR	48505	13.473773	40833	-0.08422	Dominated by 0LR3HR
5LR2HR	48621	13.473685	115	-0.00009	Dominated by 0LR3HR
5LR1HR	48764	13.473682	143	0.00000	Dominated by 0LR3HR
3LR3HR	54306	13.471626	-4870	0.00062	Dominated by 0LR3HR
3LR1HR	54469	13.471574	5705	-0.00211	Dominated by 0LR3HR
1LR1HR	59176	13.471004	4707	-0.00057	Dominated by 0LR3HR

Table A5.14.12 Alternative HSUVs (Ness, 1999)

	Cost	QALY	inc Cost	inc QALY	ICER
No_COL	4378	13.475123			
0LR3HR	7293	13.511077	2915	0.03595	81,070
0LR2HR	7478	13.511038	185	-0.00004	Dominated by 0LR3HR
0LR1HR	7673	13.511028	195	-0.00001	Dominated by 0LR3HR
5LR3HR	48505	13.473932	40833	-0.03710	Dominated by 0LR3HR
5LR2HR	48621	13.473840	115	-0.00009	Dominated by 0LR3HR
5LR1HR	48764	13.473837	143	0.00000	Dominated by 0LR3HR
3LR3HR	54306	13.471699	5542	-0.00214	Dominated by 0LR3HR
3LR1HR	54469	13.471645	163	-0.00005	Dominated by 0LR3HR
1LR1HR	59176	13.471008	4707	-0.00064	Dominated by 0LR3HR

Table A5.14.13 Alternative HSUVs – cancer-free, LR and HR

	Cost	QALY	inc Cost	inc QALY	ICER
No_COL	4378	13.4858			
0LR3HR	7293	24.3986	2915	0.003	1,142,623
0LR2HR	7478	24.3961	185	0.003	Dominated by 0LR3HR
0LR1HR	7673	24.3929	195	9.356	Dominated by 0LR3HR
5LR3HR	48505	15.0371	40833	0.038	Dominated by 0LR3HR
5LR2HR	48621	14.9988	115	0.001	Dominated by 0LR3HR
5LR1HR	48764	14.9978	143	0.914	Dominated by 0LR3HR
3LR3HR	54306	14.1067	5542	0.548	Dominated by 0LR3HR
3LR1HR	54469	14.0838	163	14.084	Dominated by 0LR3HR
1LR1HR	59176	13.5586	4707	13.559	Dominated by 0LR3HR

Table A5.14.14 COL reimbursement KRW 5,680,000

	Cost	QALY	inc Cost	inc QALY	ICER
No_COL	4378	13.48582			
0LR3HR	157871	13.58154	153493	0.095721	1,603,549
0LR2HR	166063	13.58149	8192	-0.000052	Dominated by 0LR3HR
0LR1HR	174725	13.58146	8662	-0.000026	Dominated by 0LR3HR
5LR3HR	2133515	13.47495	1958790	-0.106509	Dominated by 0LR3HR
5LR2HR	2138833	13.47483	5319	-0.000118	Dominated by 0LR3HR
5LR1HR	2145156	13.47483	6323	-0.000003	Dominated by 0LR3HR
3LR3HR	2396549	13.47192	-216808	0.000898	Dominated by 0LR3HR
3LR1HR	2403858	13.47185	258702	-0.002980	Dominated by 0LR3HR
1LR1HR	2613357	13.47102	209499	-0.000832	Dominated by 0LR3HR

Table A5.14.15 COL reimbursement KRW 1,650,000

	Cost	QALY	inc Cost	inc QALY	ICER
No_COL	4377.96	13.48582			
0LR3HR	49969.83	13.58154	45592	0.095721	476,300
0LR2HR	52423.96	13.58149	2454	-0.000052	Dominated by 0LR3HR
0LR1HR	55018.97	13.58146	2595	-0.000026	Dominated by 0LR3HR
5LR3HR	639441.65	13.47495	584423	-0.106509	Dominated by 0LR3HR
5LR2HR	641031.67	13.47483	1590	-0.000118	Dominated by 0LR3HR
5LR1HR	642926.17	13.47483	1895	-0.000003	Dominated by 0LR3HR
3LR3HR	718147.80	13.47192	-64938	0.000898	Dominated by 0LR3HR
3LR1HR	720336.13	13.47185	77410	-0.002980	Dominated by 0LR3HR
1LR1HR	783085.54	13.47102	62749	-0.000832	Dominated by 0LR3HR

Table A5.14.16 COL age 50-75

	Cost	QALY	inc Cost	inc QALY	ICER
No_COL	4378	13.48582	0	0	
0LR3HR	7293	13.58154	2915	0.09572	30,451
0LR2HR	7478	13.58149	185	-0.00005	Dominated by 0LR3HR
0LR1HR	7673	13.58146	195	-0.00003	Dominated by 0LR3HR
5LR3HR	48368	13.47503	40695	-0.10643	Dominated by 0LR3HR
5LR2HR	48489	13.47491	122	-0.00012	Dominated by 0LR3HR
5LR1HR	48633	13.47491	143	0.00000	Dominated by 0LR3HR
3LR3HR	54303	13.47192	5670	-0.00299	Dominated by 0LR3HR
3LR1HR	54466	13.47185	164	-0.00007	Dominated by 0LR3HR
1LR1HR	59176	13.47102	4709	-0.00083	Dominated by 0LR3HR

Table A5.14.17 COL age 40-80

	Cost	QALY	inc Cost	inc QALY	ICER
No_COL	6270	14.871115			
0LR3HR	8949	15.025109	2679	0.154	17,396
0LR2HR	9127	15.025042	178	0.000	Dominated by 0LR3HR
0LR1HR	9315	15.024999	188	0.000	Dominated by 0LR3HR
5LR3HR	49528	14.855246	40213	-0.170	Dominated by 0LR3HR
5LR2HR	49626	14.855110	98	0.000	Dominated by 0LR3HR
5LR1HR	49760	14.855107	135	0.000	Dominated by 0LR3HR
3LR3HR	54851	14.851740	5091	-0.003	Dominated by 0LR3HR
3LR1HR	54994	14.851669	143	0.000	Dominated by 0LR3HR
1LR1HR	59319	14.850738	4325	-0.001	Dominated by 0LR3HR

Table A5.14.87 Non-risk based strategy compared to No_COL

	Cost	QALY	inc Cost	inc QALY	ICER
No_COL	4489	13.486132			Dominant
3LR3HR	54495	13.471932	50006	-0.01420	Dominated by No_COL
1LR1HR	59253	13.471011	4758	-0.00092	Dominated by No_COL

Table A5.14.19 Risk-based strategies compared to no_COL

	Cost	QALY	inc Cost	inc QALY	ICER
No_COL	4489	13.486132			
0LR3HR	7395	13.584507	2906	0.09838	29538
0LR2HR	7580	13.584454	185	-0.00005	Dominated by 0LR3HR
0LR1HR	7775	13.584427	195	-0.00003	Dominated by 0LR3HR
5LR3HR	48710	13.475073	40935	-0.10935	Dominated by 0LR3HR
5LR2HR	48827	13.474953	117	-0.00012	Dominated by 0LR3HR
5LR1HR	48969	13.474950	142	0.00000	Dominated by 0LR3HR
3LR3HR	54495	13.471932	5526	-0.00302	Dominated by 0LR3HR

Table A5.15 Quality assessment: cost-utility analysis of COL surveillance in CRCS, NHI Korea

1. Was the research question stated?	Y
2. Was the economic importance of the research question stated?	Y
3. Was/were the viewpoint(s) of the analysis clearly stated and justified?	Y
4. Was a rationale reported for the choice of the alternative programmes or interventions compared?	Y
5. Were the alternatives being compared clearly described?	Y
6. Was the form of economic evaluation stated?	Y
7. Was the choice of form of economic evaluation justified in relation to the questions addressed?	Y
8. Was/were the source(s) of effectiveness estimates used stated?	Y
9. Were details of the design and results of the effectiveness study given (if based on a single study)?	NA
10. Were details of the methods of synthesis or meta-analysis of estimates given (if based on an overview of a number of effectiveness studies)?	NA
11. Were the primary outcome measure(s) for the economic evaluation clearly stated?	Y
12. Were the methods used to value health states and other benefits stated?	Y
13. Were the details of the subjects from whom valuations were obtained given?	Y
14. Were productivity changes (if included) reported separately?	NA
15. Was the relevance of productivity changes to the study question discussed?	NA
16. Were quantities of resources reported separately from their unit cost?	N
17. Were the methods for the estimation of quantities and unit costs described?	Y
18. Were currency and price data recorded?	Y
19. Were details of price adjustments for inflation or currency conversion given?	NA
20. Were details of any model used given?	Y
21. Was there a justification for the choice of model used & the key parameters on which it was based?	Y
22. Was the time horizon of cost and benefits stated?	Y
23. Was the discount rate stated/justified?	Y
24. Was an explanation given if cost or benefits were not discounted?	NA
25. Were the details of statistical test(s) and confidence intervals given for stochastic data?	Y
26. Was the approach to sensitivity analysis described?	Y
27. Was the choice of variables for sensitivity analysis justified?	Y
28. Were the ranges over which the parameters were varied stated?	Y
29. Were appropriate comparisons made when conducting the incremental analysis?	Y
30. Was an incremental analysis reported?	Y
31. Were major outcomes presented in a disaggregated as well as aggregated form?	Y
32. Was the answer to the study question given?	Y
33. Did conclusions follow from the data reported?	Y
34. Were conclusions accompanied by the appropriate caveats?	Y
35. Were generalisability issues addressed?	P

N no; **NA** not applicable; **P** partly; **Y** yes